

NavChip™ Series 3 *Precision 6-Axis MEMS Inertial Measurement Unit*



GENERAL DESCRIPTION

The NavChip™ Series 3 is a high precision MEMS 6-axis inertial measurement unit (IMU). Using proprietary MEMS technologies and advanced signal processing techniques, the NavChip achieves a level of performance, miniaturization, and environmental ruggedness superior to other IMUs of its size.

The NavChip is especially well-suited for embedded applications where small size, low cost, and low power consumption are required. It is fully factory-calibrated and temperature compensated over an operating range of -40°C to +85°C.

APPLICATIONS

- Augmented and Virtual Reality
- Unmanned Systems
- Robotics
- Camera & Antenna Stabilization
- Pedestrian Navigation
- GPS/INS Integration
- Aiming & Alignment

FEATURES

- Fully-compensated $\Delta\Theta$ and ΔV outputs
- Gyro bias in-run stability 4°/hr
- Angular random walk 0.18°/√hr
- Accel bias in-run stability 0.006 mg
- Velocity random walk 0.02m/s/√hr
- Full-scale angular rate of 2000°/s
- Full-scale acceleration of $\pm 16g$
- Low power consumption 135mW
- Selectable built-in test (BIT) modes for commanded and continuous diagnostic monitoring
- Factory calibrated bias, scale factor and misalignment (-40°C to +85°C)
- TTL UART, SPI or I²C data output interfaces
- Embedded temperature sensors
- Selectable output data types and rates (up to 1000 Hz)
- Selectable AHRS output
- External sync pin can accept optional GPS pulse-per-second or faster synchronization signal
- Single supply operation 3.25V to 5.5V
- Small 12.5 x 24.5 x 6.1 mm
- Lightweight 3 g
- Evaluation kits & adapter boards available

Contents

Electrical & Mechanical Specifications.....	3
Functional Description	6
Mechanical Renderings	7
Mechanical Interface Description.....	8
Mounting Recommendations.....	10
Ordering Information.....	11
Usage and Liability Disclaimer	11

Electrical & Mechanical Specifications

ABSOLUTE MAXIMUM RATINGS

PARAMETER	MIN	MAX	UNITS
VDD to GND	-0.3	+6.0	V
Digital Inputs/Outputs to GND	-0.3	+3.3	V
Analog Inputs to GND	-0.3	+3.3	V
Operating Temperature Range	-40	+85	°C
Storage Temperature Range	-40	+85	°C

Stresses beyond those listed under “Absolute Maximum Ratings” may cause permanent damage to the device. Functional operation of the device at these or any other conditions beyond those indicated in the operational section of this specification is not implied. Exposure to absolute maximum rating conditions for extended periods may affect device reliability.

ESD CAUTION



ESD (electrostatic discharge) sensitive device. Charged devices and circuit boards can discharge without detection. Although this product features patented or proprietary protection circuitry, damage may occur on devices subjected to high energy ESD. Therefore, proper ESD precautions should be taken to avoid performance degradation or loss of functionality.

GYROSCOPE PERFORMANCE (3.3V, +25°C, unless otherwise specified)

PARAMETER	TYP ¹	MAX ²	UNITS
Full Scale Range	± 2000	-	°/s
In-Run Bias Stability (Allan Variance), Class A	4	5	°/hr
In-Run Bias Stability (Allan Variance), Class B	5	10	°/hr
Bias Accuracy over Operating Temp Range, Class A	± 0.2	± 0.3	°/s
Bias Accuracy over Operating Temp Range, Class B	± 0.2	± 0.4	°/s
g Sensitive Bias	0.004	0.03	°/s/g
Scale Factor Accuracy over Operating Temp Range	± 0.05	± 0.4	%
Scale Factor Linearity ³	0.01	0.05	%
Angle Random Walk	0.18	0.3	°/√hr
Axis Mutual Alignment Accuracy	± 0.03	± 0.2	degrees

ACCELEROMETER PERFORMANCE (3.3V, +25°C, unless otherwise specified)

PARAMETER	TYP	MAX	UNITS
Full Scale Range	± 16	-	g
In-Run Bias Stability (Allan Variance), Class A	0.006	0.01	mg
In-Run Bias Stability (Allan Variance), Class B	0.04	0.1	mg
Bias Accuracy over Operating Temp Range	± 3	± 15	mg
Scale Factor Accuracy over Operating Temp Range	± 0.09	± 0.2	%
Scale Factor Linearity ⁴	0.06	0.2	%
Velocity Random Walk, Class A	0.02	0.02	m/s/√hr
Velocity Random Walk, Class B	0.03	0.05	m/s/√hr
Axis Mutual Alignment Accuracy	± 0.03	± 0.2	degrees

¹ TYP Specs are mean values or 1σ for values that are nominally zero.

² MAX Specs are maximum factory test limits unless otherwise specified.

³ Factory test up to 810 °/s

⁴ Factory test over ± 1g

DIGITAL INPUTS/OUTPUTS

PARAMETER	MIN	TYP	MAX	UNITS
Logic "0" Input Voltage	0	-	0.6	V
Logic "1" Input Voltage	2.1	-	3	V
Logic "0" Output Voltage	-	0	0.4	V
Logic "1" Output Voltage	2.4	3	-	V
Logic "0" Input Current	-	± 2	-	µA
Logic "1" Input Current	-	± 2	-	µA
Input Capacitance	-	10	-	pF

TEMPERATURE SENSOR PERFORMANCE

PARAMETER	MIN	TYP	MAX	UNITS
Temperature Sensing Range	-40	-	+85	°C
Resolution	-	0.05	-	°C
Accuracy	-	± 2.5	± 3.5	°C
Repeatability	-	± 0.5	-	°C

FLASH MEMORY

PARAMETER	Nominal	UNITS
Endurance	10,000	Cycles
Data Retention	20	Years

TIMING

PARAMETER	Nominal	UNITS
Power-on Startup (including 0.5s bootloader timeout)	< 1.0	Seconds
Built In Test Time (commanded TBIT)	< 2.0	Seconds

PHYSICAL

PARAMETER	Nominal	UNITS
Size (W x L x H, including interconnect stack height)	12.5 x 24.5 x 6.1	mm
Weight	3	grams
RoHS Compliant	Yes	-

ELECTRICAL

PARAMETER	SYMBOL	CONDITIONS	MIN	TYP	MAX	UNITS
Supply Voltage Range	Vdd		3.25	3.3	5.5	V
Supply Current	Idd	after startup		40		mA
Internal power supply decoupling capacitance	-	-		200		µF

UART INTERFACE

PARAMETER	MIN	TYP	MAX	UNITS
Baud rate	38,400	115,200	921,600	Bits per second
Baud rate deviation from nominal	-1.5	± 0.2	1.5	%
8 data bits, 1 start bit, no parity	-	-	-	-

GYROSCOPE ALLAN VARIANCE EXAMPLE

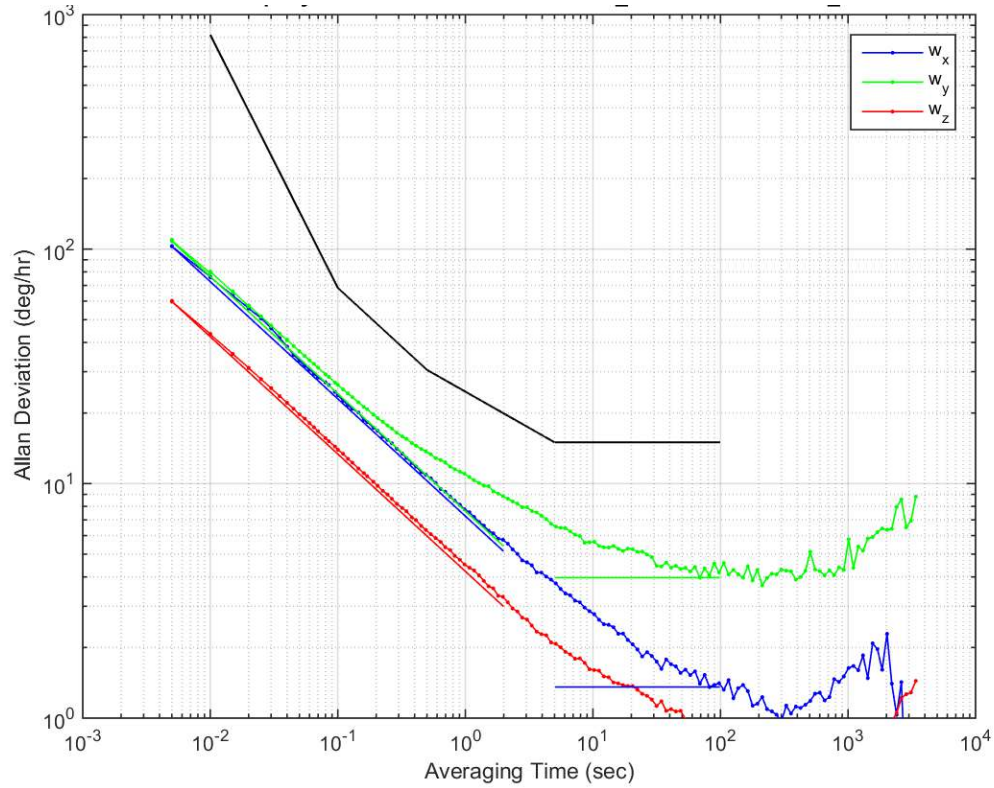

ACCELEROMETER ALLAN VARIANCE EXAMPLE

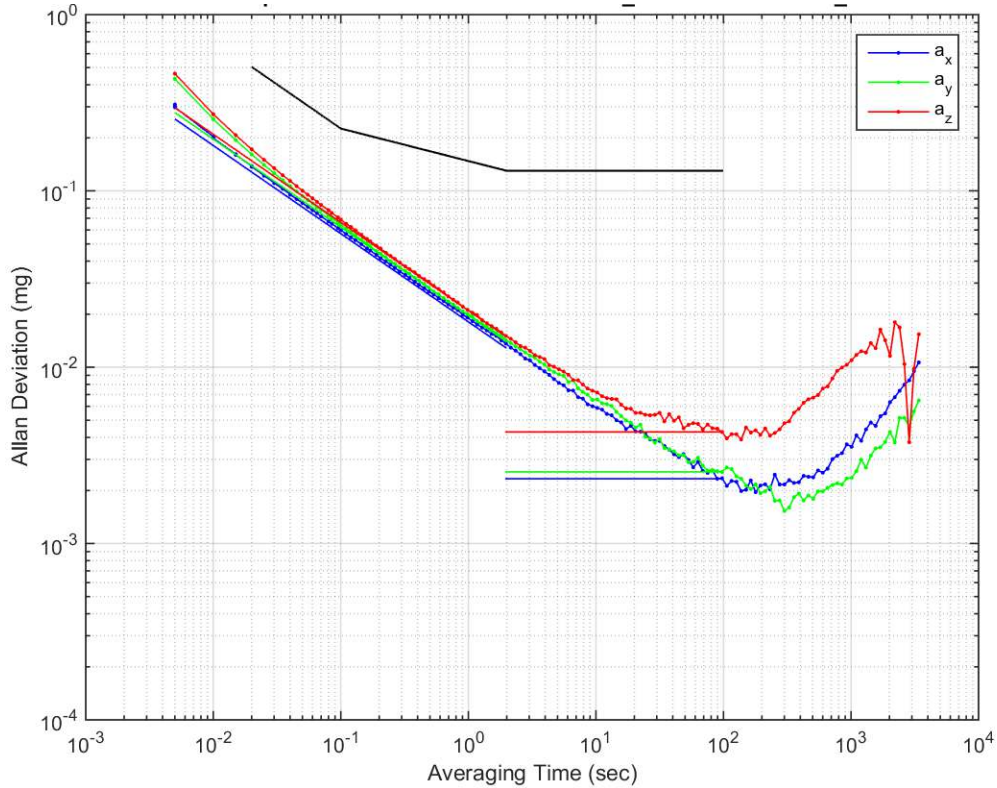

Functional Description

The NavChip is a miniature precision IMU that outputs compensated $\Delta\Theta$ and ΔV data and is factory calibrated over a -40°C to $+85^{\circ}\text{C}$ temperature range.

The NavChip implements UART, SPI and I²C communication interfaces. The UART interface is capable of operating at baud rates ranging from 38400 baud to 921600 baud. All of the interfaces support user-selectable data output rates up to 1000 Hz. The NavChip communication protocol is packet-based and enables the user to configure the device, receive data, and monitor the device's status. See the NavChip Interface Control Document (ICD) for details on the operation of these interfaces.

Figure 1 depicts the NavChip's internal processing. The NavChip performs data acquisition and processing at a precise 1000 Hz rate. Compensation is performed to correct the sensors' biases, scale factors, misalignments, etc. Data is output at 200 Hz (5 msec period) by default, but a user may change the output period to select other rates as described in the ICD.

The NavChip's internal sampling may optionally be synchronized to a precision external clock reference such as a GPS pulse-per-second (PPS) signal. Any periodic signal whose period is an integer number of milliseconds between 1 and 1000 can be used for synchronization. Refer to the ICD for timing requirements and details on how to configure NavChip for external synchronization.

Factory calibration corrects for misalignments between the sensor axes resulting in highly orthogonal measurement axes. Alignment of these IMU "intrinsic" axes relative to a host platform (such as a robot, UAV, or camera) will be affected by the precision of the mounting of the NavChip onto the mating board as well as the mounting of the mating board in the host platform.

NavChip provides registers for programming a boresight matrix which rotates the $\Delta\Theta$ and ΔV vectors from the NavChip's internal (intrinsic) reference frame to the vehicle's body frame. This allows customers to compensate for "extrinsic" misalignment angles (the rotation between the intrinsic axes and the host platform). An extrinsic calibration tool is available which will allow the user to determine the boresight matrix relative to a reference jig having two orthogonal surfaces and load it into the NavChip.

The acceleration measurements are computed relative to a coordinate origin point at 1.5mm below the center of the bottom surface of NavChip (i.e. the center of the NavChip footprint on the mating board).

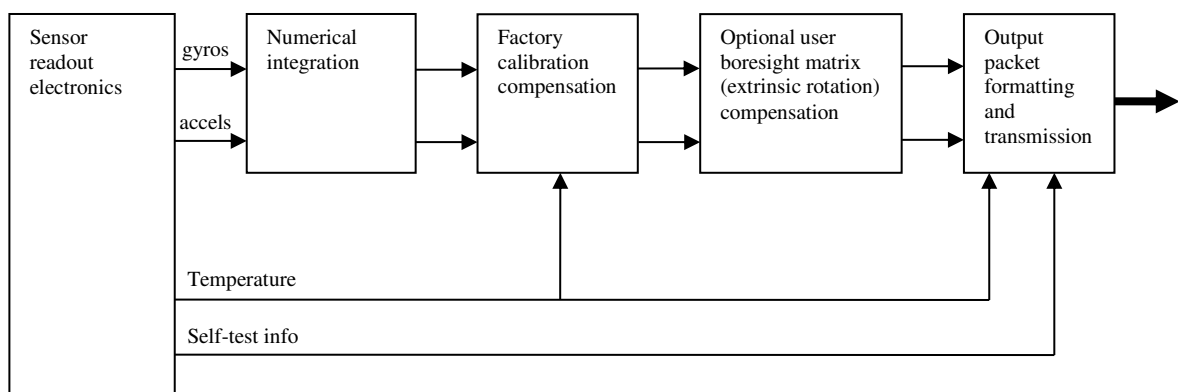

Figure 1: Functional block diagram

Mechanical Renderings

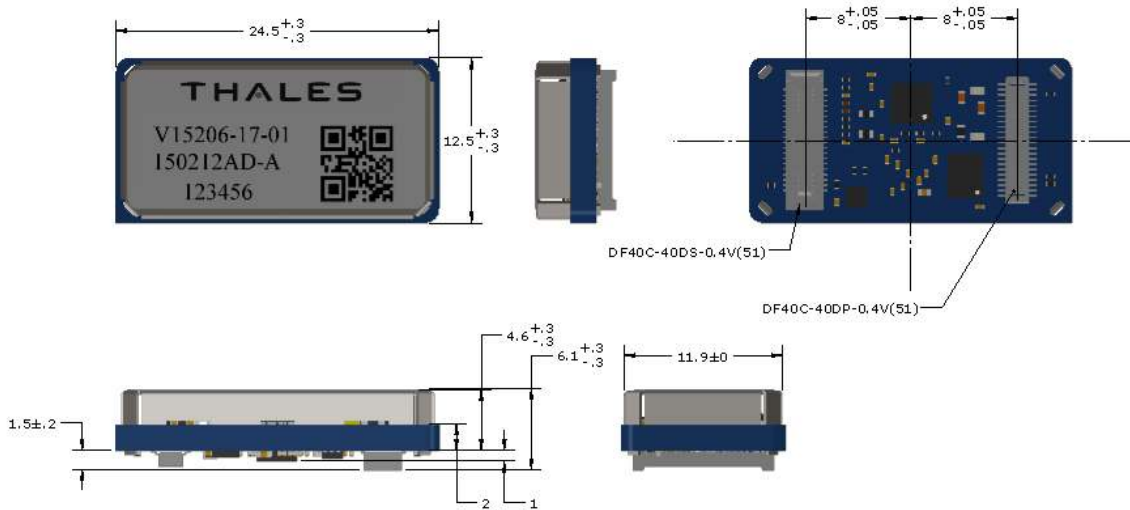

Figure 2: Dimensions (mm)

Mechanical Interface Description

The NavChip has two high density and high contact reliability interface connectors that allow users to design the device directly into their system. The two connectors – designated “P1” and “J1” – have different genders to avoid mis-assembly when plugging the NavChip in.

Connector “J1” is a 40-pin interconnect that is used only to supply ground to the NavChip’s RF shield, provide access to I²C communication, and secure mounting of the NavChip.

Connector “P1” is a 40-pin interconnect that carries all other electrical interfaces between the NavChip and the user’s board. Please note that P1 actually has 44 pins; the outermost 4 pins are used for structural support only and do not carry any signals. Refer to Figure 3 below for more information regarding pin numbering.

IMPORTANT: DO NOT CONNECT ANY SIGNALS TO THE NC PINS. DOING SO MAY DAMAGE THE NAVCHIP OR CAUSE IT TO MALFUNCTION.

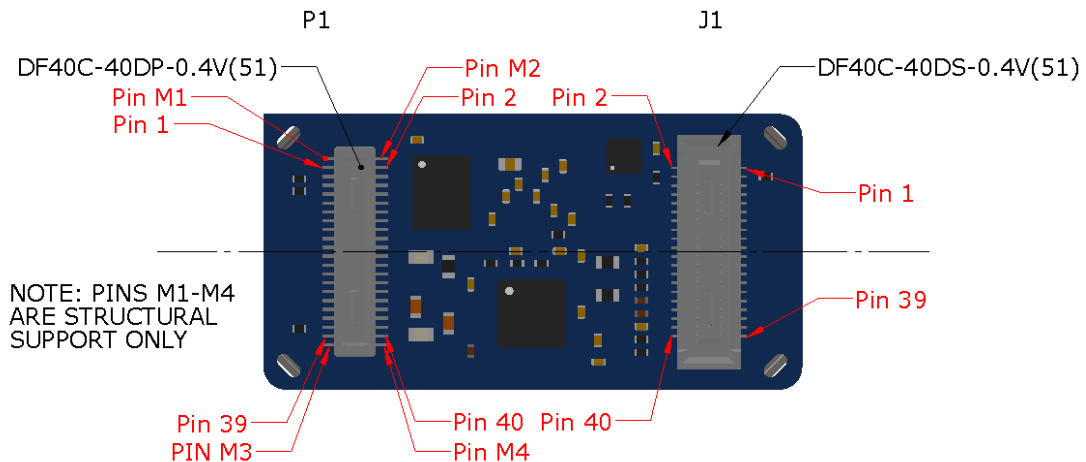

Figure 3: J1/P1 Connector

Table 1: J1 Pin Functional Descriptions

PIN	PIN NAME	PIN TYPE	PIN DESCRIPTION
1	GND	Ground	Power Ground
2	GND	Ground	Power Ground
3-12	NC	-	Reserved for Factory Use
13*	I2C3_SCL	Input	I ² C SCL
14*	I2C3_SDA	Input/Output	I ² C SDA
15-38	NC	-	Reserved for Factory Use
39	GND	Ground	Power Ground
40	GND	Ground	Power Ground

*Use pull-up resistor to V_{dd} with a value appropriate for your design.

Table 2: P1 Pin Functional Descriptions

PIN	PIN NAME	PIN TYPE	PIN DESCRIPTION
1	Vlogic	Output	3V logic reference output (25mA max.)
2	Vlogic	Output	3V logic reference output
3-8	NC	-	Reserved for Factory Use
9-10	GND	Ground	Ground
11	SPI_SCK	Input	SPI CLK
12	SPI_SCK	Input	SPI CLK
13	SPI_SDO	Output	MISO
14	SPI_SDO	Output	MISO
15	SPI_SDI	Input	MOSI
16	SPI_SDI	Input	MOSI
17-21	NC	-	Reserved for Factory Use
22	Vin	Power	3.25V to 5.5V
23-24	NC	-	Reserved for Factory Use
25	TTL_RX	Input	UART receiver
26	TTL_RX	Input	UART receiver
27	TTL_TX	Output	UART transmitter
28	TTL_TX	Output	UART transmitter
29	SYNC_IN	Input	TTL sync input to external rising edge signal
30	SYNC_IN	Input	TTL sync input to external rising edge signal
31	GND	Ground	Ground
32	Vin	Power	3.25V to 5.5V
33	NC	-	Reserved for Factory Use
34	NC	-	Reserved for Factory Use
35	DRDY	Output	Data Ready
36	DRDY	Output	Data Ready
37	SPI_CS	Input	SPI Chip Select (active-low)
38	SPI_CS	Input	SPI Chip Select (active-low)
39-40	GND	Ground	Ground

Note: It is recommended to connect identical signals across connector for redundancy.

Mounting Recommendations

The NavChip is designed to allow an end user the ability to integrate the device directly into their circuit card. Two high performance interface connectors allow users to easily install the NavChip while ensuring excellent performance from the device.

Please follow these layout guidelines for optimal performance in your application:

1. Refer to Figure 2: NavChip Mechanical Dimensions for clearances required for proper mounting.
2. It is recommended that no components are placed under the NavChip
3. Separation and alignment of the connector footprint is critical. Variance from the specified 8mm separation will induce un-calibrated stresses into the NavChip and may effect performance
4. Connectors are high retention strength so please use care when separating the NavChip from the mating connectors. It is important to subject both ends of the device to equal force when removing it.
5. Only handle the NavChip in an ESD controlled environment. Proper ESD guidelines (i.e. a grounded strap) should be used when handling the device.

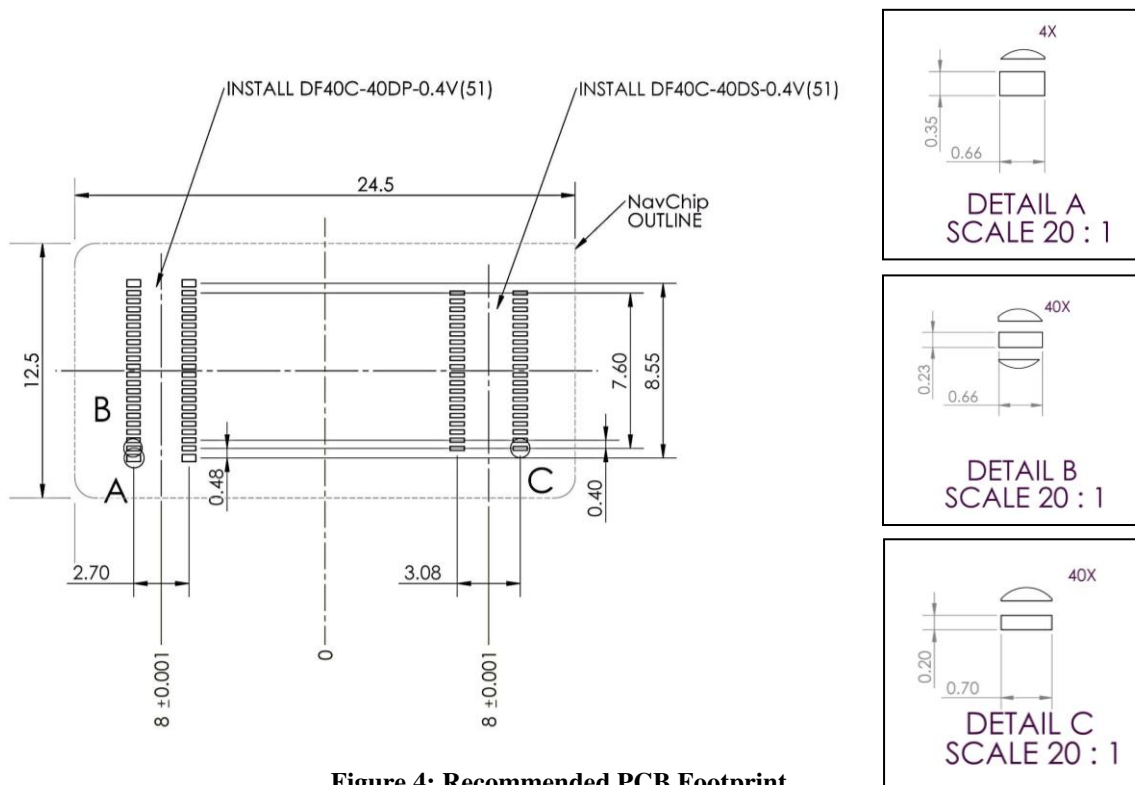

Figure 4: Recommended PCB Footprint

Ordering Information

Please reference to the following part numbers when ordering your desired NavChip configuration.

NAVCHIP	PART NUMBER
NavChip, Class A	V15206-17-02
NavChip, Class B	V15206-17-01

Usage and Liability Disclaimer

Thales Defense & Security Inc. (TDSI) products are sold pursuant to TDSI's terms and conditions of sale. Information furnished herein is believed to be accurate; however, no responsibility is assumed by TDSI from its use or for any infringements of patents or other rights of third parties that may result from its use or the use of TDSI products. TDSI reserves the right to make changes, corrections, modifications or improvements to this document and to the products described herein at any time, without notice. TDSI makes no warranty, representation or guarantee, either express or implied, regarding the information in this document or the suitability of its products for any particular purpose and specifically disclaims any and all liability, including without limitation consequential or incidental damages. Unless expressly indicated otherwise in a separate writing by TDSI, no license is granted by implication or otherwise under any intellectual property right of TDSI or any third party, including but not limited to any patent or patent rights, copyright or trademark rights.

TDSI products are not intended for any application in which the failure of the product could result in personal injury, death or severe property damage. TDSI sensors should not be used or sold for use in any conventional or mass-destructive weapons or any other weapons or life-threatening applications, nor in safety-critical applications such as life-support equipment, transportation, aerospace and nuclear instruments, undersea equipment, or any other applications where unexpected behavior of the sensors could cause bodily harm. Should Buyer purchase or use TDSI products for any such unintended or unauthorized application, Buyer shall indemnify and hold TDSI and its officers, employees, subsidiaries, affiliates, and distributors harmless against any and all claims, costs, damages, expenses, and reasonable legal fees arising out of, directly or indirectly, any claim of severe property damage, personal injury, bodily harm or death associated with such unintended or unauthorized use, even if such claim alleges that TDSI was negligent regarding the design or manufacture of the part.

Resale of TDSI products with provisions different from the statements and/or technical features set forth in this document shall immediately void any warranty granted by TDSI for the TDSI product or service described herein and shall not create or extend in any manner whatsoever, any liability of TDSI. Thales Defense & Security and the Thales logo are trademarks or registered trademarks of TDSI in various countries. Information in this document supersedes and replaces all information previously supplied.

©2020 Thales Defense & Security Inc. All rights reserved.

Contact us at +1 781 541 7650 or sales@thalesvisionix.com for more details on using Thales Defense & Security Inc. technology or becoming a distribution partner.

Thales Defense & Security, Inc.
700 Technology Park Drive
Billerica, MA 01821 USA

T: +1 781 541 6330
F: +1 781 541 6329
www.thalesvisionix.com
www.intersense.com