



WR-10 Waveguide Voltage Variable Attenuator, W Band, 75 GHz to 110 GHz, 30 dB Gain, 8 dB Loss, UG-387/U-M Flange

**TECHNICAL DATA SHEET**

**PEWGA3215**

**Features**

- WR-10 Waveguide Voltage Variable Attenuator
- 75 GHz to 110 GHz
- W Band
- Insertion Loss: 8 dB typ
- Attenuation Range: 0 dB to 30 dB typ
- DC Control Voltage: 0 Vdc to +5 Vdc
- Max RF Input Power (CW) +23 dBm
- 50 Ohm Design
- RF Input and Output Waveguide Flange UG-387/U-M
- Solder Pins for DC Control Voltage and Ground
- Operational Temperature Range -40°C to +80°C
- Rugged and Compact Aluminum Gold Plated Package Design

**Applications**

- Test & Measurement
- Military & Commercial Communications
- Military Electronic Systems
- Research & Development

**Description**

The PEWGA3215 is a WR-10 Waveguide Voltage Variable Attenuator, operating across the W Band from 75 GHz to 110 GHz. This 50 Ohm design has 8 dB typ insertion loss with a maximum (CW) input power handling of +23 dBm. The control voltage is 0 Vdc to +5 Vdc to adjust the attenuation level from 0 dB to 30 dB typ across the full frequency band. The rugged and small size aluminum package design is gold plated and supports a UG-387/U-M waveguide flange pattern at the RF input and output ports. Solder pins are used for DC voltage control and ground. The module operates across a wide temperature range from -40°C to +80°C.

**Configuration**

Waveguide Flange	WR-10 UG-387/U-M
Body Material and Plating	Aluminum, Gold

**Electrical Specifications** Values at 25°C, sea level

Description	Minimum	Typical	Maximum	Units
Frequency Range	75		110	GHz
Typical Attenuation Value	0		30	dB
Insertion Loss	5.5	8	10.3	dB
Maximum Pin (CW)			23	dBm
Control Voltage	0		5	Vdc

**Electrical Notes:**

- 1.) Open and short-circuit loads are not recommended at the attenuator output.
- 2.) Ensure proper 50 Ohm load before turning the attenuator "ON".
- 3.) Do not put any foreign objects inside the waveguide. Warranty will be voided.

Click the following link (or enter part number in "SEARCH" on website) to obtain additional part information including price, inventory and certifications: [WR-10 Waveguide Voltage Variable Attenuator, W Band, 75 GHz to 110 GHz, 30 dB Gain, 8 dB Loss, UG-387/U-M Flange PEWGA3215](#)



WR-10 Waveguide Voltage Variable Attenuator, W Band, 75 GHz to 110 GHz, 30 dB Gain, 8 dB Loss, UG-387/U-M Flange

**TECHNICAL DATA SHEET**

**PEWGA3215**

**Biasing Up and Power Down Procedure**

**Biasing Up Procedure**

Step 1	Connect Ground Pin
Step 2	Apply DC Supply Voltage
Step 3	Turn ON RF input

**Power Down Procedure**

Step 1	Turn OFF RF input
Step 2	Turn OFF DC Supply Voltage
Step 3	Remove Ground

**Mechanical Specifications**

Description	Flange 1	Waveguide	Flange 2
Interface	UG-387/U-M	WR-10	UG-387/U-M

**Temperature**

Operating Range

-40 to +80 deg C

Storage Range

-40 to +100 deg C

**Size**

Length

1.75 in [44.45 mm]

Width

1.5 in [38.1 mm]

Height

0.975 in [24.77 mm]

Weight

0.15 lbs [68.04 g]

**Compliance Certifications** (see [product page](#) for current document)

**Plotted and Other Data**

Notes:

- Values at 25 °C, sea level

Click the following link (or enter part number in "SEARCH" on website) to obtain additional part information including price, inventory and certifications: [WR-10 Waveguide Voltage Variable Attenuator, W Band, 75 GHz to 110 GHz, 30 dB Gain, 8 dB Loss, UG-387/U-M Flange PEWGA3215](#)



WR-10 Waveguide Voltage Variable Attenuator, W Band, 75 GHz to 110 GHz, 30 dB Gain, 8 dB Loss, UG-387/U-M Flange

**TECHNICAL DATA SHEET**

**PEWGA3215**

**Absolute Maximum Rating**

Parameter	Rating
Operating Temperature	-40°C to +80°C
Storage Temperature	-40°C to +100°C
Total Power Dissipation	0.1W
Power Handling (CW)	+23dBm
Control Voltage	+10V

**Typical Performance Data**

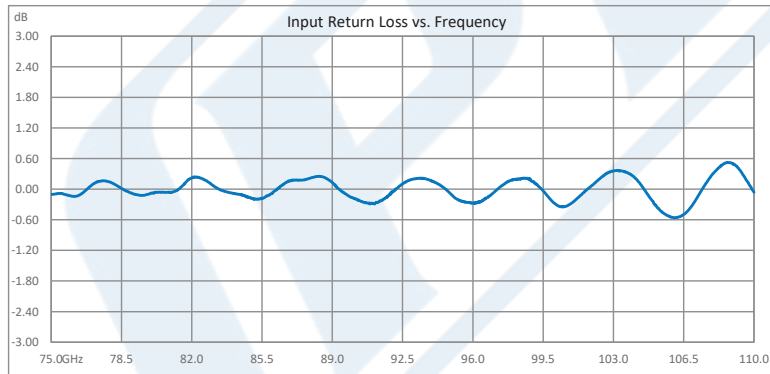
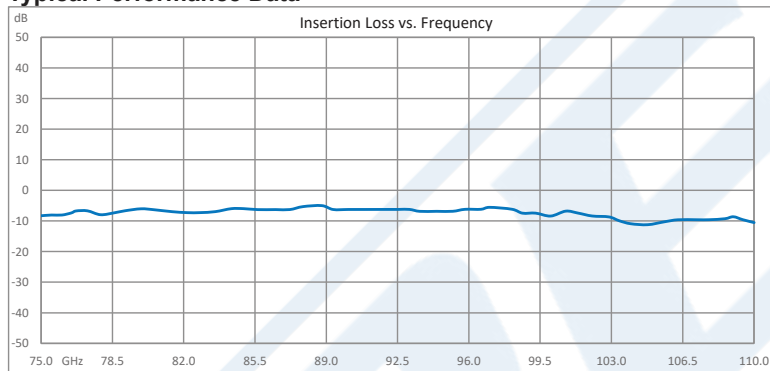

Click the following link (or enter part number in "SEARCH" on website) to obtain additional part information including price, inventory and certifications: [WR-10 Waveguide Voltage Variable Attenuator, W Band, 75 GHz to 110 GHz, 30 dB Gain, 8 dB Loss, UG-387/U-M Flange PEWGA3215](#)



WR-10 Waveguide Voltage Variable Attenuator, W Band, 75 GHz to 110 GHz, 30 dB Gain, 8 dB Loss, UG-387/U-M Flange

**TECHNICAL DATA SHEET**

**PEWGA3215**

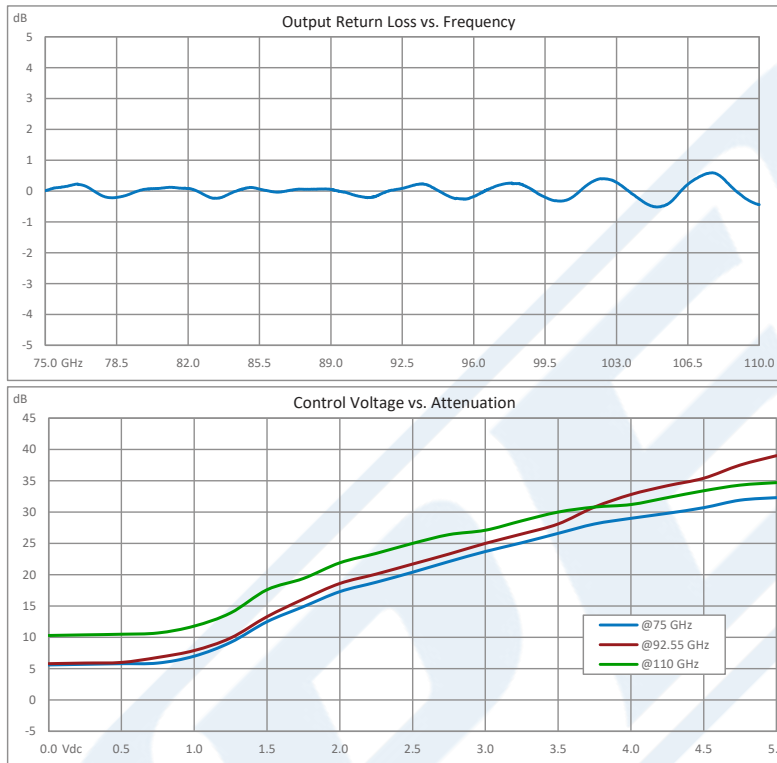

WR-10 Waveguide Voltage Variable Attenuator, W Band, 75 GHz to 110 GHz, 30 dB Gain, 8 dB Loss, UG-387/U-M Flange from Pasternack Enterprises has same day shipment for domestic and International orders. Our RF, microwave and millimeter wave products maintain a 99.4% availability and are part of the broadest selection in the industry.

Click the following link (or enter part number in "SEARCH" on website) to obtain additional part information including price, inventory and certifications: [WR-10 Waveguide Voltage Variable Attenuator, W Band, 75 GHz to 110 GHz, 30 dB Gain, 8 dB Loss, UG-387/U-M Flange PEWGA3215](https://www.pasternack.com/wr-10-waveguide-voltage-variable-attenuator-w-band-75-ghz-to-110-ghz-0-to-30-db-0-to-5-volt-control-ug-387-u-m-flange-pewga3215-p.aspx)

URL: <https://www.pasternack.com/wr-10-waveguide-voltage-variable-attenuator-w-band-75-ghz-to-110-ghz-0-to-30-db-0-to-5-volt-control-ug-387-u-m-flange-pewga3215-p.aspx>

The information contained in this document is accurate to the best of our knowledge and representative of the part described herein. It may be necessary to make modifications to the part and/or the documentation of the part, in order to implement improvements. Pasternack reserves the right to make such changes as required. Unless otherwise stated, all specifications are nominal. Pasternack does not make any representation or warranty regarding the suitability of the part described herein for any particular purpose, and Pasternack does not assume any liability arising out of the use of any part or documentation.

# PEWGA3215 CAD Drawing

WR-10 Waveguide Voltage Variable Attenuator, W Band, 75 GHz to 110 GHz, 30 dB Gain, 8 dB Loss, UG-387/U-M Flange

REVISIONS			
REV.	DESCRIPTION	DATE	APPROVED
A	INITIAL RELEASE	02/04/22	TGALLA

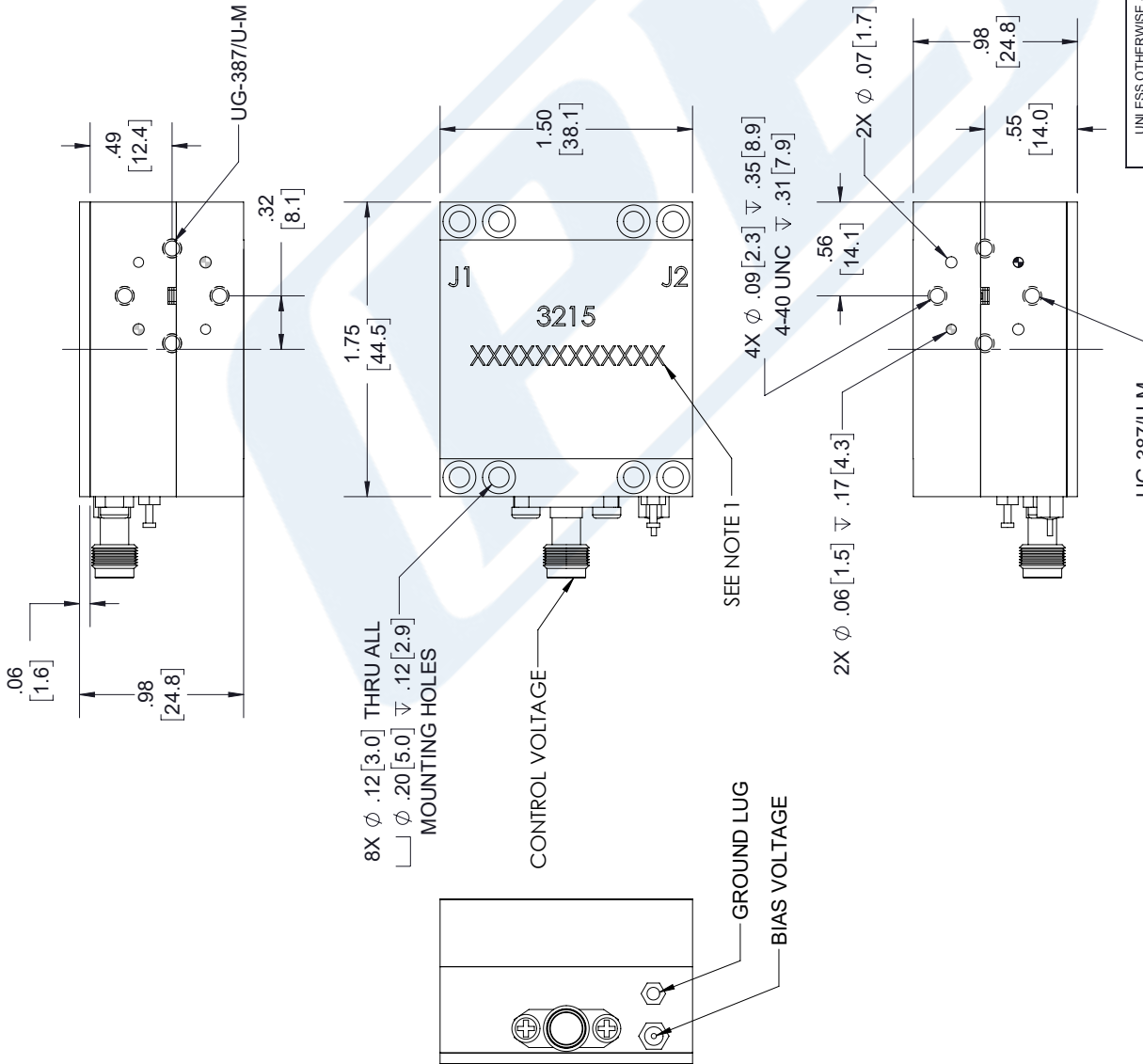
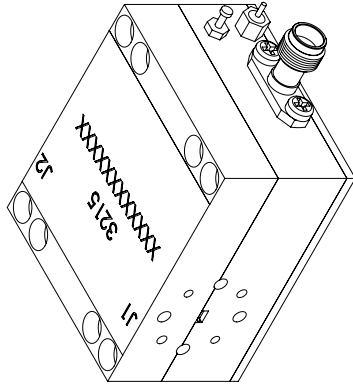

**PE PASTERNAK**  
an INFINITE brand

Pasternack Enterprises, Inc.  
P. O. Box 16759, Irvine, CA 92623.  
Phone: 1.949.261.1920 | 1.866.727.8376  
Fax: 1.949.261.7451  
Website: www.pasternack.com  
E-mail: sales@pasternack.com

THIRD-ANGLE PROJECTION

THE INFORMATION AND DESIGN IN THIS DOCUMENT IS THE PROPERTY OF PASTERNAK CORPORATION. ALL RIGHTS RESERVED.

SHEET 1 OF 1  
SCALE N/A

---

UNLESS OTHERWISE SPECIFIED LEADING DIMENSIONS ARE INCHES DIMENSIONS IN [ ] ARE MILLIMETERS

TOLERANCES:

.X = ±.2	[5.08]	FRACTIONS
.XX = ±.02	[.51]	± 1/32
.XXX = ±.005	[.13]	ANGLES ± 1°

CABLE LENGTH (L) TOLERANCES:

L ≤ 12	[305]	= +1 [25] / -0
12 [305] < L ≤ 60	[1524]	= +2 [51] / -0
60 [1524] < L ≤ 120	[3048]	= +4 [102] / -0
120 [3048] < L ≤ 300	[7620]	= +6 [152] / -0
300 [7620] < L		= +5%L / -0

ALL DIMENSIONS SHOWN ARE FOR REFERENCE ONLY.

**NOTES:**

- SERIAL NUMBER AND DATE CODE ARE COMBINED. EX: 202008280001.

THESE COMMODITIES, TECHNOLOGY OR SOFTWARE WERE EXPORTED FROM THE UNITED STATES IN ACCORDANCE WITH THE EXPORT ADMINISTRATION REGULATIONS. DIVERSION CONTRARY TO U.S. LAW PROHIBITED.