

ISS.	AMEND	DATE
1	ISSUED	17/10/17

Panel cut out (front view)

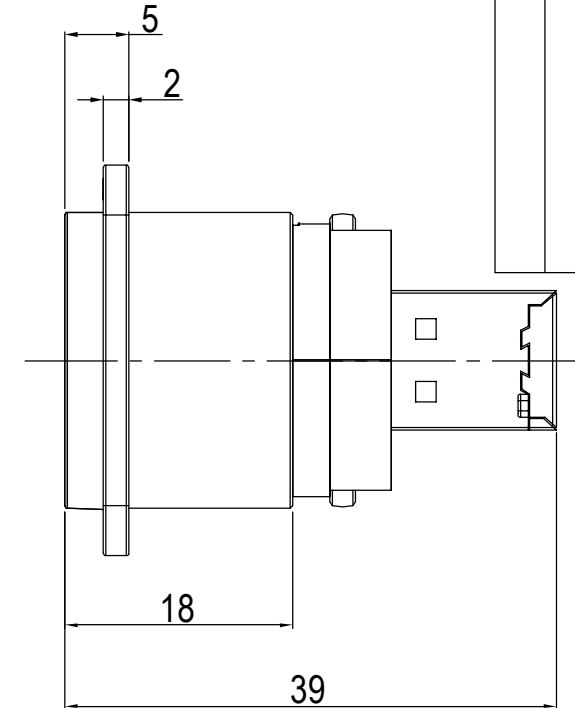
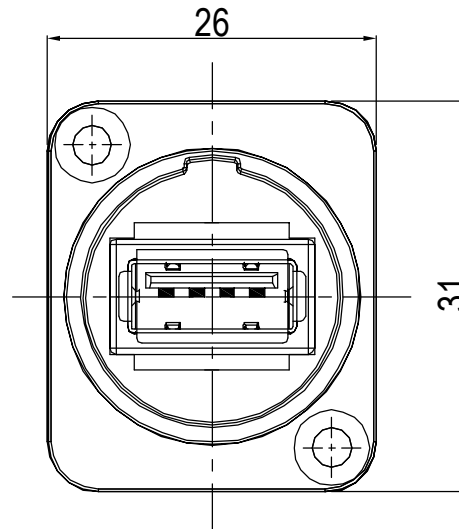
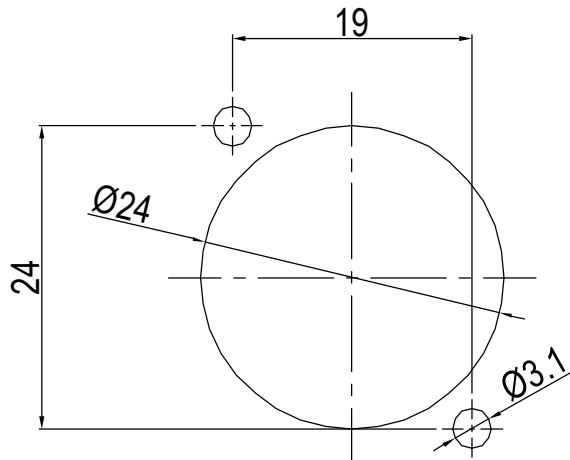

Specification + Technical Data:

- Contact Resistance: 30mΩ MAX
- Insulation Resistance : 500MΩ min
- Dielectric withstanding voltage: 500V AC one minute
- Rated Current: 1.5A
- Rated Voltage: 30V
- Temperature Range: 0°C to +50°C
- (High-Speed): 25Mbps ~ 400Mbps (Max 480Mbps)
- (Full Speed): 500Kbps ~ 10Mbps (Max 12Mbps)
- (Low Speed): 10Kbps ~ 100Kbps (Max 1.5Mbps)

Plating

- Contact : Touch Area Golden Plating 1µ"
- Soldering Area Tin Plating 40µ" min
- USB Shell: Nickel Plating 40µ" min

Contact	Standard A	Standard B
1	VBUS 14.75 - 5.25 VI	VBUS 14.4 - 5.25 VI
2	D-	D-
3	D+	D+
4	Earthing	Earthing

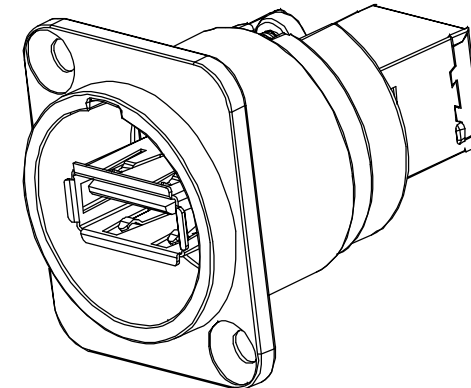

ITEM	DESCRIPTION	MATERIAL	FINISH
1	FRAME	ZINC DIECAST	BLACK
2	FT INSERT	ABS	BLACK
3	SCREW	STEEL	NICKEL
4	USB2 A-B	PBT	WHITE
5	USB2 SHELL	BRASS	NICKEL
6	CONTACTS	BRASS	GOLD

Standard A

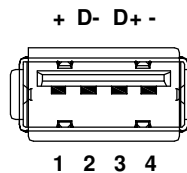

Standard B

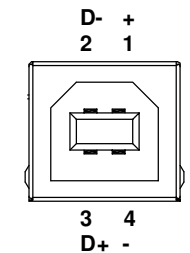

RoHS COMPLIANT

TOLERANCE
 NO DEC. PLACE ±
 1 DEC. PLACE ±
 2 DEC. PLACE ±
 HOLE Ø ±
 ANGLES ±
 UNLESS OTHERWISE STATED

Cliff Electronic Components Ltd.

76 Holmethorpe Avenue, Holmethorpe Industrial Estate,
 Redhill, Surrey, RH1 2PF, England, UK
 Tel: 01737-771375 Fax: 01737-766012 Website: www.cliffuk.co.uk

DIMENSIONS IN MILLIMETERS UNLESS OTHERWISE STATED. WORK TO DIMENSIONS. REMOVE ALL BURRS. IF IN DOUBT ASK.

3rd ANGLE PROJECTION:

DO NOT SCALE

MATERIAL:	SEE TABLE
FINISH:	SEE TABLE
DRAWN:	T.J.O.
APPROVED:	D.P.J.

TITLE:	XLR USB2 A-B FT - BLACK METAL
DRWG. No.	CP30114
FORM:	A4DRWGH