

PART NUMBER	REVISION	DESCRIPTION	FEED TYPE
2150255-2	B	FINE CRIMP HEIGHT ADJUST	PNEUMATIC
7-2150255-2	B	PNEUMATIC AND CRIMP TOOLING KIT	PNEUMATIC
7-2150255-7	A	CRIMP TOOLING KIT	-

ATLANTIC VERSION TERMINATOR INTERFACE ADAPTER

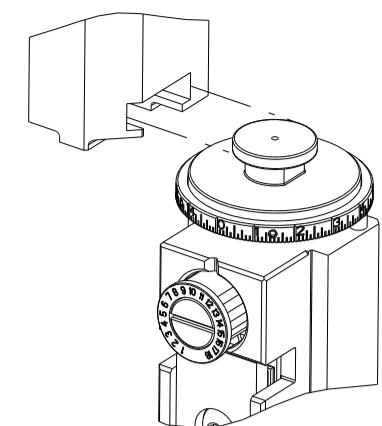

APPLICATOR DATA		
CRIMP	SIZE	TYPE
WIRE	3.00 mm [.118]	F
INSUL	4.80 mm [.189]	F
APPL INSTRUCTIONS 408-35043		

TERMINAL DATA: YAZAKI TERMINAL YAZAKI CRIMP SPECIFICATION			
TERMINAL NAME: 7.8mm FEMALE TERMINAL			
WIRE STRIP LENGTH		INSULATION DIAMETER RANGE	
5.00-6.00 [.197-.236 IN]		∅ 3.10mm MAX [.122 IN MAX]	
TERMINAL APPLICATION SPECIFICATION			
TERMINALS APPLIED			
TE TERMINAL	YAZAKI TERMINAL	TE TERMINAL	YAZAKI TERMINAL
2113260-1	7116-3050		

WIRE SIZE	CRIMP HEIGHT mm [INCH]	CRIMP HEIGHT REFERENCE SETTING
2.00mm2	1.55+/-0.05 [.061+/-0.002]	3.6
1.25mm2	1.40+/-0.05 [.055+/-0.002]	5.2
0.85mm2	1.30+/-0.05 [.051+/-0.002]	6.2
0.50mm2	1.20+/-0.05 [.047+/-0.002]	7.3

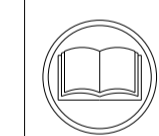

- RECOMMENDED SPARE PARTS
- REFER TO SUPPLIED INSTRUCTION SHEET FOR CLEANING, LUBRICATION AND STORAGE OF APPLICATOR.
- APPLY PART NUMBER 2-23419-6 LOCTITE TO THREADS OF ITEM 242.
- CRIMP HEIGHT REFERENCE SETTING WAS THE SETTING USED WHEN THE APPLICATOR WAS QUALIFIED AT THE FACTORY. ADJUSTMENT MAY BE NECESSARY WHEN RUNNING APPLICATOR IN THE FIELD.
- 5. UNLESS SPECIFIED OTHERWISE TORQUE VALUES SHALL BE USED ER DOCUMENT, 101-35000.
- TERMINAL PITCH NOT COMPATIBLE WITH MECHANICAL FEED.

***WARNING**
ON INSTALLATION, SET WIRE DISC TO CRIMP HEIGHT REFERENCE SETTING FOR LARGEST WIRE SIZE. CRIMP HEIGHT REFERENCE SETTINGS GREATER THAN THE VALUE SHOWN MAY CAUSE DAMAGE TO THE CRIMP TOOLING, REFER TO THE INSTRUCTION SHEET FOR PROPER SETUP AND ADJUSTMENTS.

ATLANTIC VERSION
Shown on sheets 1 of 4 & 2 of 4
(Pacific version shown on sheets 3 of 4 & 4 of 4)

LOC	DIST	REVISIONS					
		P	LTN	DESCRIPTION	DATE	OWN	APVD
A	66	A		RELEASED	18JUL2012	CC	SX
		B		ECR-23-172311	14APR2023	FZ	TE

-	1	1	2119641-1	FEED CAM, AIR FEED	248	
-	1	1	2119082-9	CAM, SNAIL, INSULATION ADJUSTMENT	244	
-	1	1	2079764-1	WASHER, WAVE SPRING, CREST-TO-CREST	243	
-	1	1	2119083-1	RETAINER, INSULATION DIAL	242	
-	1	1	2844940-4	AIR FEED MODULE	238	
-	1	1	1-18028-0	WASHER, FLAT, REG M8	192	
-	1	1	6-993111-6	PIN, SLOTTED SPRING 3.0 X 14.0	177	
-	1	1	8-22280-7	SPRING, COMPRESSION	176	
-	1	1	1752353-2	GUIDE PIN,HOLDDOWN	175	
-	1	1	1901680-2	GUIDE PIN,HOLDDOWN	174	
-	REF	REF	994970-2	COUNTER, MAGNETIC	164	
-	1	1	455888-5	SPACER, CRIMPER	82	
-	1	1	1803607-4	DOCUMENTATION PACKAGE	71	
-	2	2	2-18032-2	SCR, SET, FLT PNT, M3 X 10.0	70	
-	1	1	2119740-1	TAG, IDENTIFICATION	67	
-	2	2	2168078-1	SCREW, DRIVE, RH, RoHS, 2 x .188	66	
-	1	1	1901681-1	HOLDDOWN, TERMINAL	65	
-	1	1	2168083-2	SCR, SKT HD CAP, RoHS, M4 X 8.0	60	
-	1	1	5-18022-5	SCR, HEX HD CAP, M4 X 6.0	59	
-	4	4	2168400-4	SHCS, LOW HEAD, RoHS, M4 X 8	57	
-	2	2	2168083-8	SCR, SKT HD CAP, RoHS, M4 X 16	56	
-	2	2	5018030-1	NUT, HEX, REG, RoHS, M3	54	
-	2	2	986965-8	NUT, LOCK, HEX, TORQUE (M4)	53	
-	1	1	1-5018030-0	NUT, HEX, REG, RoHS, M3.5	52	
-	1	1	2063961-1	FEED FINGER	51	
-	1	1	1-1752354-1	STANDOFF,HOLD-DOWN	50	
-	1	1	18023-9	SCR, SKT HD CAP M4 X 6.0	49	
-	1	1	2119655-5	APPLICATOR BASIC ASSEMBLY, EF	46	
-	1	1	1803517-1	RAM ASSEMBLY, EF ATLANTIC	44	
-	1	1	1803602-1	SCR, BHSC, RoHS (M8 X 25)	41	
-	8	8	1-18028-2	WASHER, FLAT, REG M4	33	
-	2	2	2168083-9	SCR, SKT HD CAP, RoHS, M4 X 20	31	
-	2	2	2168083-2	SCR, SKT HD CAP, RoHS, M4 X 8.0	29	
-	1	1	240639-1	STRIPPER (MACHINING)	27	
-	2	2	1-2168083-5	SCR, SKT HD CAP, RoHS, M4 X 30	25	
-	1	1	1752371-3	PLATE, STRIP GUIDE	24	
-	2	2	2-22281-3	SPRING, COMPRESSION	22	
-	1	1	1803292-1	DRAG	20	
-	2	2	1901259-4	GUIDE, LOWER STRIP	18	
-	4	4	1-2079383-1	SCR, BHSC, RoHS (M6 X 12)	17	
-	1	1	1-240641-2	SPACER	16	
-	1	1	1752360-1	SPACER,HOLD-DOWN	13	
-	1	1	240833-4	PLATE, REAR SHEAR	11	
-	-	-	-	-	10	
-	1	1	6-690482-3	PLATE, FRONT SHEAR	9	
-	1	2	1	1803001-8	ANVIL, COMBINATION, END FEED	8
-	1	1	1	1-690474-7	BLADE, SLUG	7
-	1	1	1	2-240641-9	SPACER	5
-	1	1	1	4-238011-5	BLOCK, CRIMPER SPACER	4
-	1	2	1	4-2119582-6	CRIMPER, INSULATION F PREMIUM	3
-	1	1	1	455888-8	SPACER, CRIMPER	2
-	1	2	1	1633609-3	CRIMPER, WIRE	1
-	77	72	-2	PART NO	DESCRIPTION	ITEM NO

DIMENSIONS: mm		TOLERANCES UNLESS OTHERWISE SPECIFIED:		OWN: C. CHEN 28MAR2012	TE Connectivity Harrisburg, PA 17105-3608
		0 PLC ± 1 PLC ± 2 PLC ± 3 PLC ± 4 PLC ± ANGLES ± FINISH ±		CHK: S. XI 28MAR2012	
MATERIAL: -		FINISH: -		APVD: J. CRUZ 28MAR2012	NAME: Ocean End Feed Applicator
-		-		APPLICATION SPEC: -	SIZE: A1
-		-		WEIGHT: -	CAGE CODE: 00779
-		-		Customer Accessible Production Drawing	DRAWING NO: C=2150255
-		-		SCALE: 1:1	SHEET 1 OF 4
-		-		REV: B	

LOC		DIST		REVISIONS			
A	66	P	LTM	DESCRIPTION	DATE	DWN	APVD
		-		SEE SHEET 1			

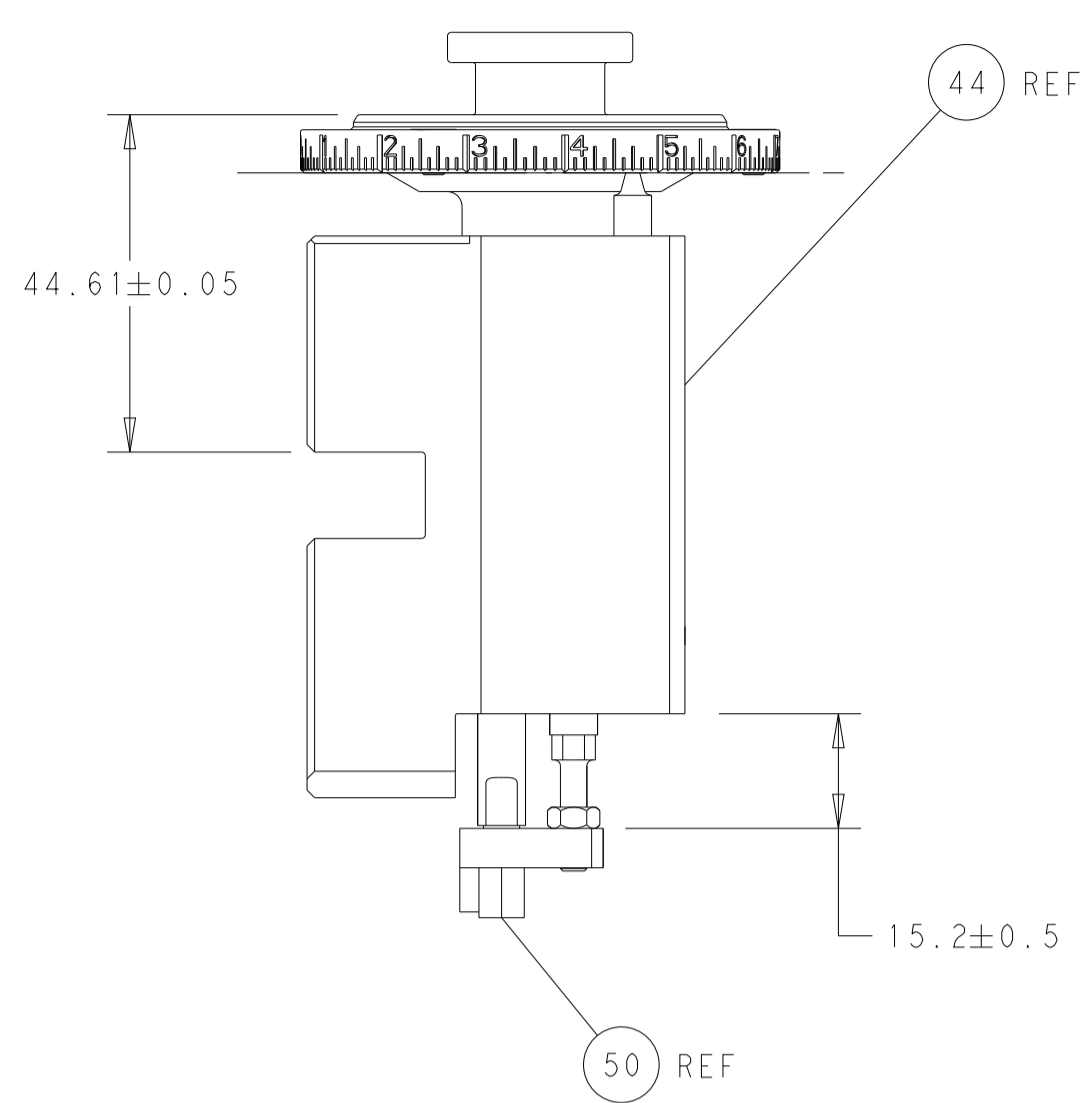

RAM AND HOLDDOWN SET-UP

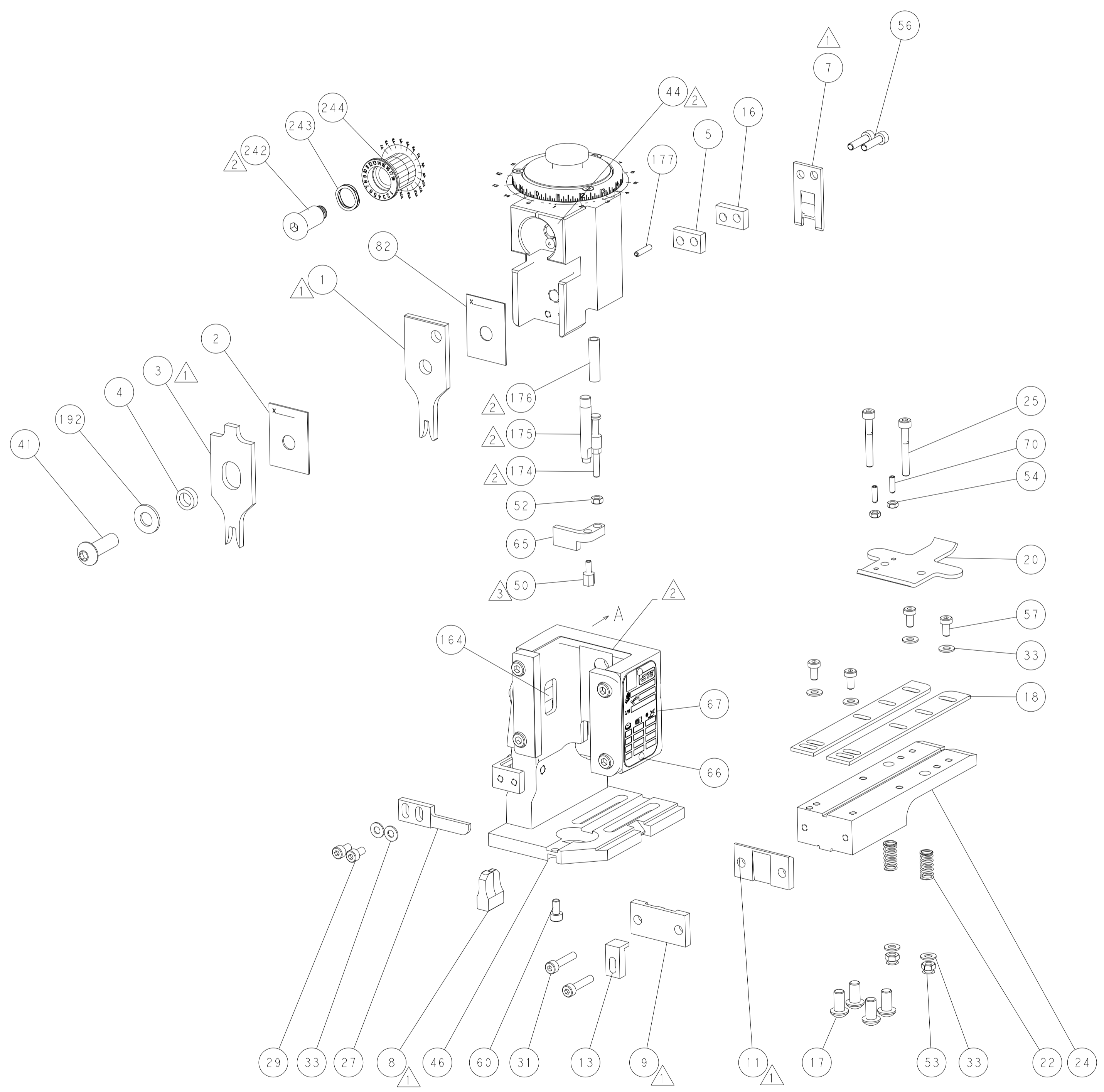

FEED TYPE

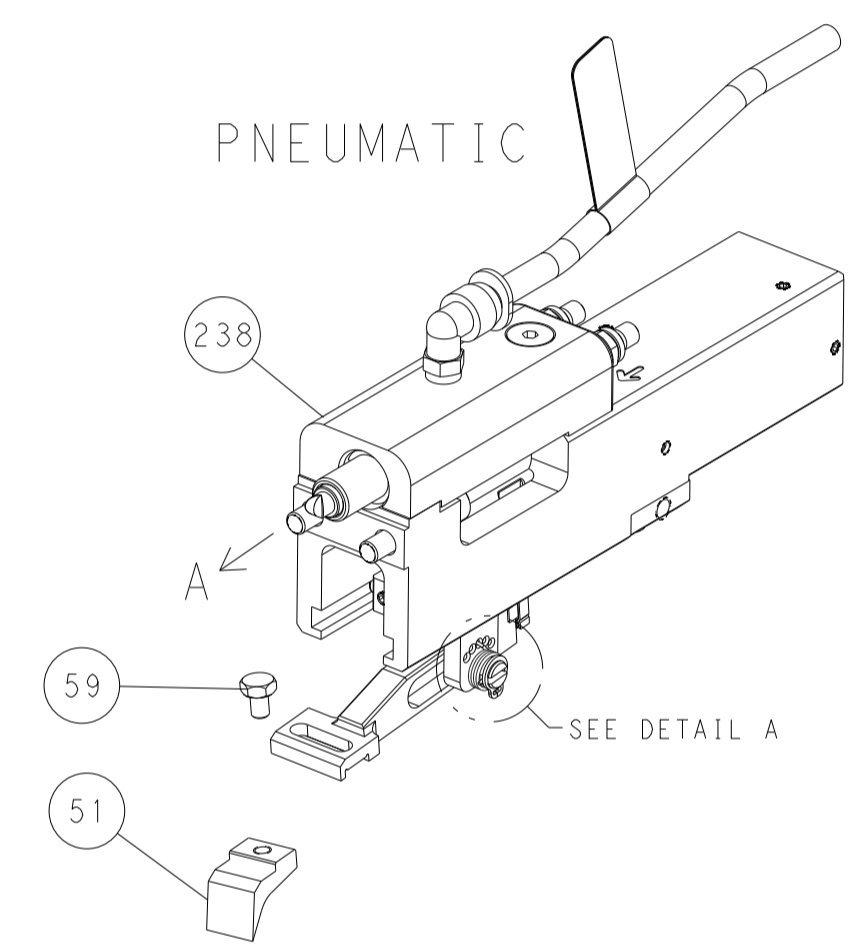

FEED SPRING SETTING POSITION

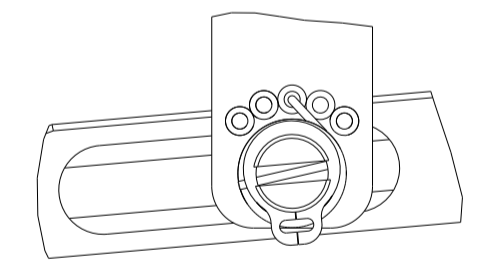

DETAIL A

CAM POSITION

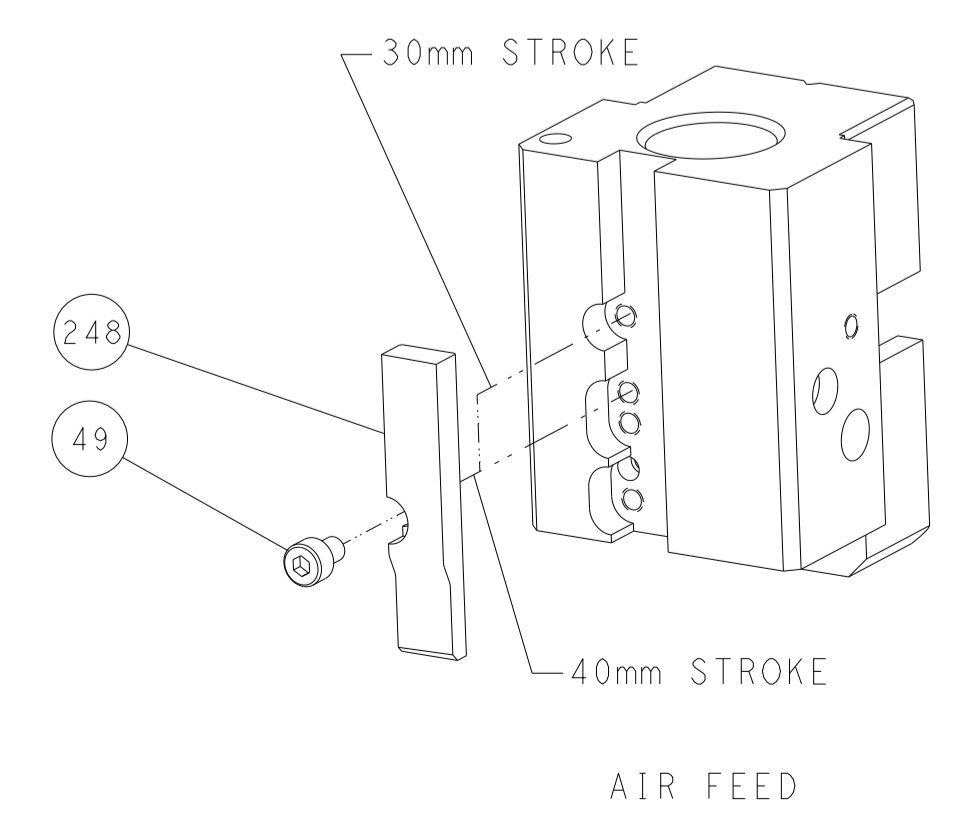

ATLANTIC VERSION
 Shown on sheets 1 of 4 & 2 of 4
 (Pacific version shown on sheets 3 of 4 & 4 of 4)

<small>THIS DRAWING IS UNPUBLISHED. RELEASED FOR PUBLICATION BY TYCO ELECTRONICS CORPORATION. ALL RIGHTS RESERVED.</small>		DWN: C. CHEN 28MAR2012 CHK: S. XI 28MAR2012 APVD: J. CRUZ 28MAR2012	TE Connectivity Harrisburg, PA 17105-3608
DIMENSIONS: mm TOLERANCES UNLESS OTHERWISE SPECIFIED: 0 PLC ± 1 PLC ± 2 PLC ± 3 PLC ± 4 PLC ± ANGLES ° ± MATERIAL: - FINISH: -		NAME: Ocean End Feed Applicator SIZE: A1 CAGE CODE: 00779 DRAWING NO: C=2150255 RESTRICTED TO: -	SCALE: 1:1 SHEET: 2 of 4 REV: B
CUSTOMER ACCESSIBLE PRODUCTION DRAWING		SHEETS 3 & 4 ARE NOT REQUIRED FOR ATLANTIC VERSION	

DIMENSIONING AND TOLERANCING PER ASME Y14.5M-2009.

C

B

A

C

B

A

PART NUMBER	REVISION	DESCRIPTION	FEED TYPE
2-2150255-2	B	FINE CRIMP HEIGHT ADJUST	PNEUMATIC
7-2150255-7	A	CRIMP TOOLING KIT	-

PACIFIC VERSION TERMINATOR
 INTERFACE ADAPTER

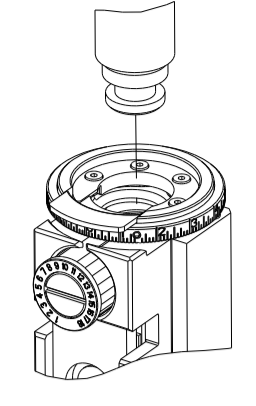

APPLICATOR DATA		
CRIMP	SIZE	TYPE
WIRE	3.00 mm [.118]	F
INSUL	4.80 mm [.189]	F
APPL INSTRUCTIONS 408-35043		

TERMINAL DATA: YAZAKI TERMINAL YAZAKI CRIMP SPECIFICATION			
TERMINAL NAME: 7.8mm FEMALE TERMINAL			
WIRE STRIP LENGTH	INSULATION DIAMETER RANGE		
5.00-6.00 [.197-.236 IN]	3.10mm MAX [.122 IN MAX]		
TERMINAL APPLICATION SPECIFICATION			
TERMINALS APPLIED			
TE TERMINAL	YAZAKI TERMINAL	TE TERMINAL	YAZAKI TERMINAL
2113260-1	7116-3050		

WIRE SIZE	CRIMP HEIGHT mm [INCH]	CRIMP HEIGHT REFERENCE SETTING
2.00mm2	1.55+/-0.05 [.061+/-0.002]	3.6
1.25mm2	1.40+/-0.05 [.055+/-0.002]	5.2
0.85mm2	1.30+/-0.05 [.051+/-0.002]	6.2
0.50mm2	1.20+/-0.05 [.047+/-0.002]	7.3

- 1 RECOMMENDED SPARE PARTS
- 2 REFER TO SUPPLIED INSTRUCTION SHEET FOR CLEANING, LUBRICATION AND STORAGE OF APPLICATOR.
- 3 APPLY PART NUMBER 2-23419-6 LOCTITE TO THREADS OF ITEM 242.
- 4 CRIMP HEIGHT REFERENCE SETTING WAS THE SETTING USED WHEN THE APPLICATOR WAS QUALIFIED AT THE FACTORY. ADJUSTMENT MAY BE NECESSARY WHEN RUNNING APPLICATOR IN THE FIELD.
- 5 UNLESS SPECIFIED OTHERWISE TORQUE VALUES SHALL BE USED ER DOCUMENT, 101-35000.
- 6 TERMINAL PITCH NOT COMPATIBLE WITH MECHANICAL FEED.

***WARNING**
 ON INSTALLATION, SET WIRE DISC TO CRIMP HEIGHT REFERENCE SETTING FOR LARGEST WIRE SIZE. CRIMP HEIGHT REFERENCE SETTINGS GREATER THAN THE VALUE SHOWN MAY CAUSE DAMAGE TO THE CRIMP TOOLING, REFER TO THE INSTRUCTION SHEET FOR PROPER SETUP AND ADJUSTMENTS.

PACIFIC VERSION
 Shown on sheets 3 of 4 & 4 of 4
 (Atlantic version shown on sheets 1 of 4 & 2 of 4)

LOC	DIST	REVISIONS					
		P	LTN	DESCRIPTION	DATE	OWN	APVD
A	66	-	-	SEE SHEET 1	-	-	-

-	1	2119082-9	CAM, SNAIL, INSULATION ADJUSTMENT	244
-	1	2079764-1	WASHER, WAVE SPRING, CREST-TO-CREST	243
-	1	2119083-1	RETAINER, INSULATION DIAL	242
-	1	2844940-4	AIR FEED MODULE	238
-	1	1-18028-0	WASHER, FLAT, REG M8	192
-	4	2079383-9	SCR, BHSC, RoHS (M6 X 20)	186
-	1	6-993111-6	PIN, SLOTTED SPRING 3.0 X 14.0	177
-	1	8-22280-7	SPRING, COMPRESSION	176
-	1	1752353-2	GUIDE PIN,HOLDDOWN	175
-	1	1901680-2	GUIDE PIN,HOLDDOWN	174
-	REF	994970-2	COUNTER, MAGNETIC	164
-	1	2119641-2	FEED CAM, AIR FEED	152
-	1	2168083-8	SCR, SKT HD CAP, RoHS, M4 X 16	144
-	1	2119655-6	APPLICATOR BASIC ASSEMBLY, EF	141
-	1	1803518-1	RAM ASSEMBLY, EF PACIFIC	140
-	1	455888-5	SPACER, CRIMPER	82
-	1	1803607-4	DOCUMENTATION PACKAGE	71
-	2	2-18032-2	SCR, SET, FLT PNT, M3 X 10.0	70
-	1	2119740-1	TAG, IDENTIFICATION	67
-	2	2168078-1	SCREW, DRIVE, RH, RoHS, 2 x .188	66
-	1	1901681-1	HOLDDOWN, TERMINAL	65
-	1	5-18022-5	SCR, HEX HD CAP, M4 X 6.0	59
-	4	2168400-4	SHCS, LOW HEAD, RoHS, M4 X 8	57
-	2	2168083-8	SCR, SKT HD CAP, RoHS, M4 X 16	56
-	2	5018030-1	NUT, HEX, REG, RoHS, M3	54
-	2	986965-8	NUT, LOCK, HEX, TORQUE (M4)	53
-	1	1-5018030-0	NUT, HEX, REG, RoHS, M3.5	52
-	1	2063961-1	FEED FINGER	51
-	1	1-1752354-1	STANDOFF,HOLD-DOWN	50
-	1	18023-9	SCR, SKT HD CAP M4 X 6.0	49
-	1	1803602-1	SCR, BHSC, RoHS (M8 X 25)	41
-	8	1-18028-2	WASHER, FLAT, REG M4	33
-	2	2168083-9	SCR, SKT HD CAP, RoHS, M4 X 20	31
-	2	2168083-2	SCR, SKT HD CAP, RoHS, M4 X 8.0	29
-	1	240639-1	STRIPPER (MACHINING)	27
-	2	1-2168083-5	SCR, SKT HD CAP, RoHS, M4 X 30	25
-	1	1752371-3	PLATE, STRIP GUIDE	24
-	2	2-22281-3	SPRING, COMPRESSION	22
-	1	1803292-1	DRAG	20
-	2	1901259-4	GUIDE, LOWER STRIP	18
-	1	1-240641-2	SPACER	16
-	1	1752360-1	SPACER,HOLD-DOWN	13
-	1	240833-4	PLATE, REAR SHEAR	11
-	-	-	-	10
-	1	6-690482-3	PLATE, FRONT SHEAR	9
1	1	1803001-8	ANVIL, COMBINATION, END FEED	8
-	1	1-690474-7	BLADE, SLUG	7
-	1	2-240641-9	SPACER	5
-	1	4-238011-5	BLOCK, CRIMPER SPACER	4
1	1	4-2119582-6	CRIMPER, INSULATION F PREMIUM	3
-	1	455888-8	SPACER, CRIMPER	2
1	1	1633609-3	CRIMPER, WIRE	1
-	77-22	PART NO	DESCRIPTION	ITEM NO

DIMENSIONS:		TOLERANCES UNLESS OTHERWISE SPECIFIED:		MATERIAL:		FINISH:		WEIGHT:		SCALE:	
mm	0 PLC ±	1 PLC ±	2 PLC ±	3 PLC ±	4 PLC ±	ANGLES	FINISH	-	-	1:1	SHEET 3 OF 4
Customer Accessible Production Drawing		Customer Accessible Production Drawing		Customer Accessible Production Drawing		Customer Accessible Production Drawing		Customer Accessible Production Drawing		Customer Accessible Production Drawing	

LOC	DIST	REVISIONS			
P	LTN	DESCRIPTION	DATE	DMN	APVD
A	66	SEE SHEET 1	-	-	-

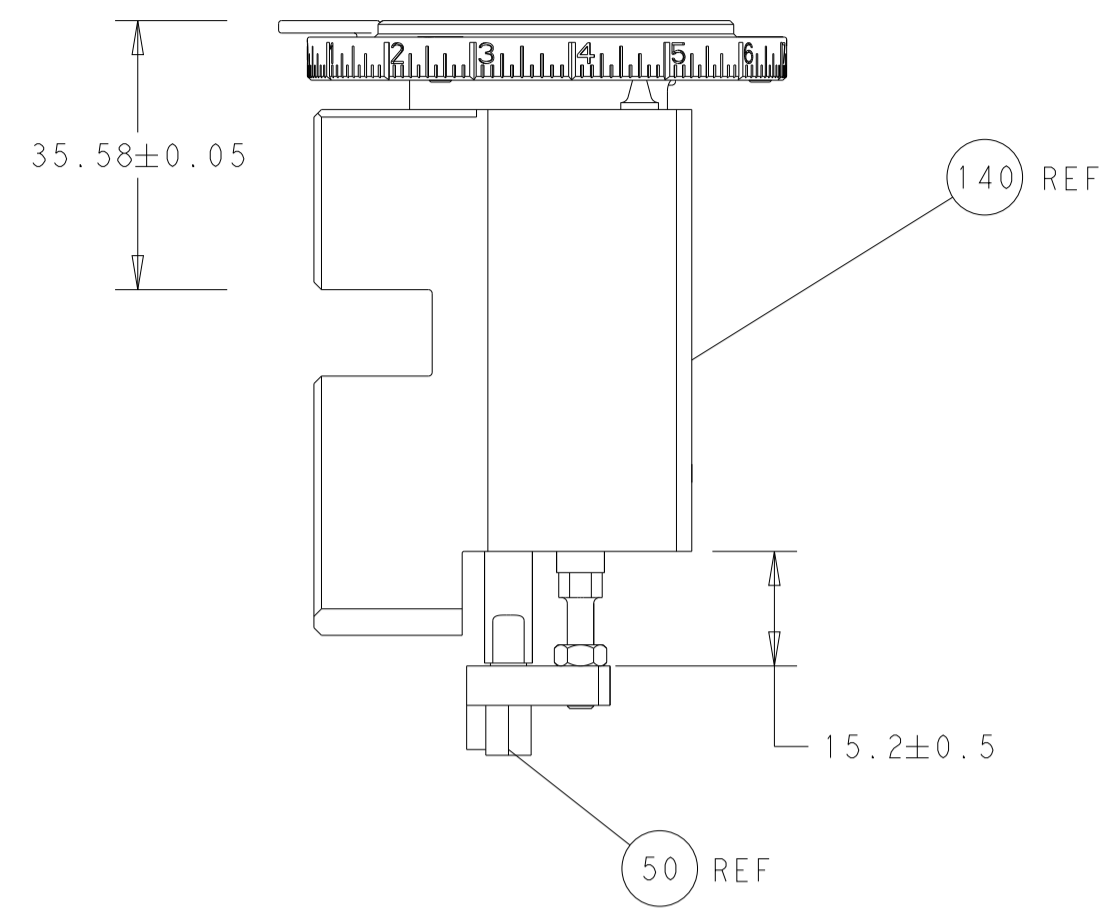

RAM AND HOLDDOWN SET-UP

FEED TYPE

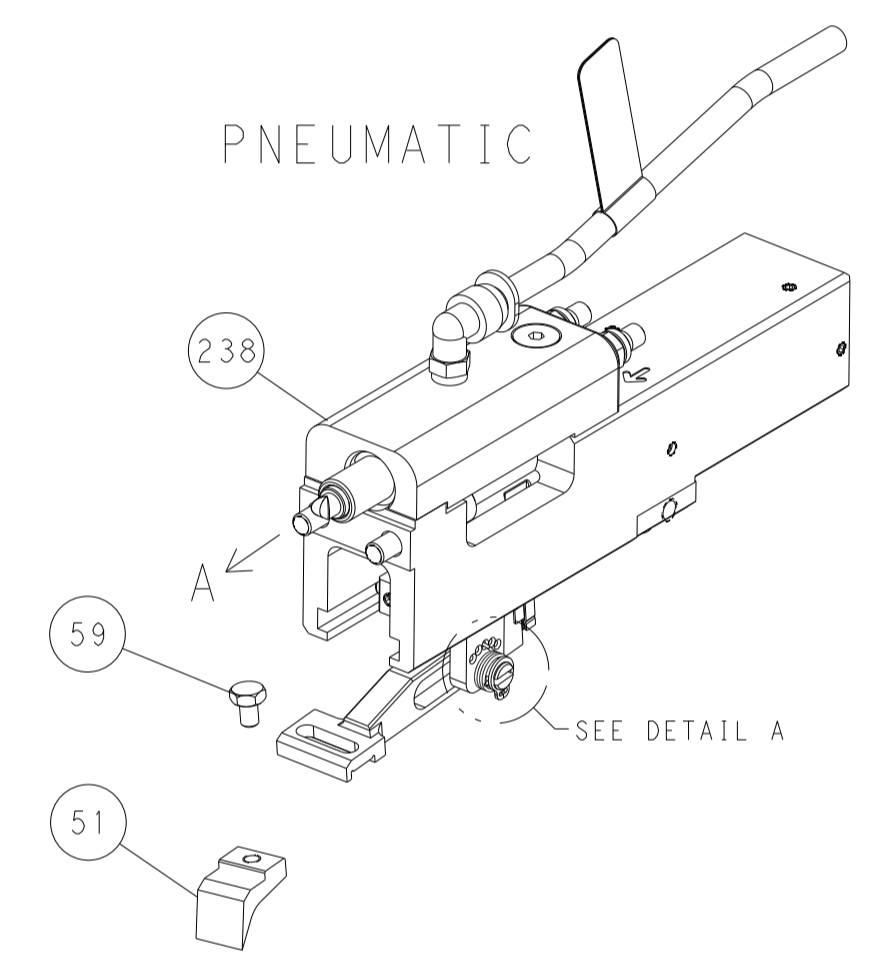
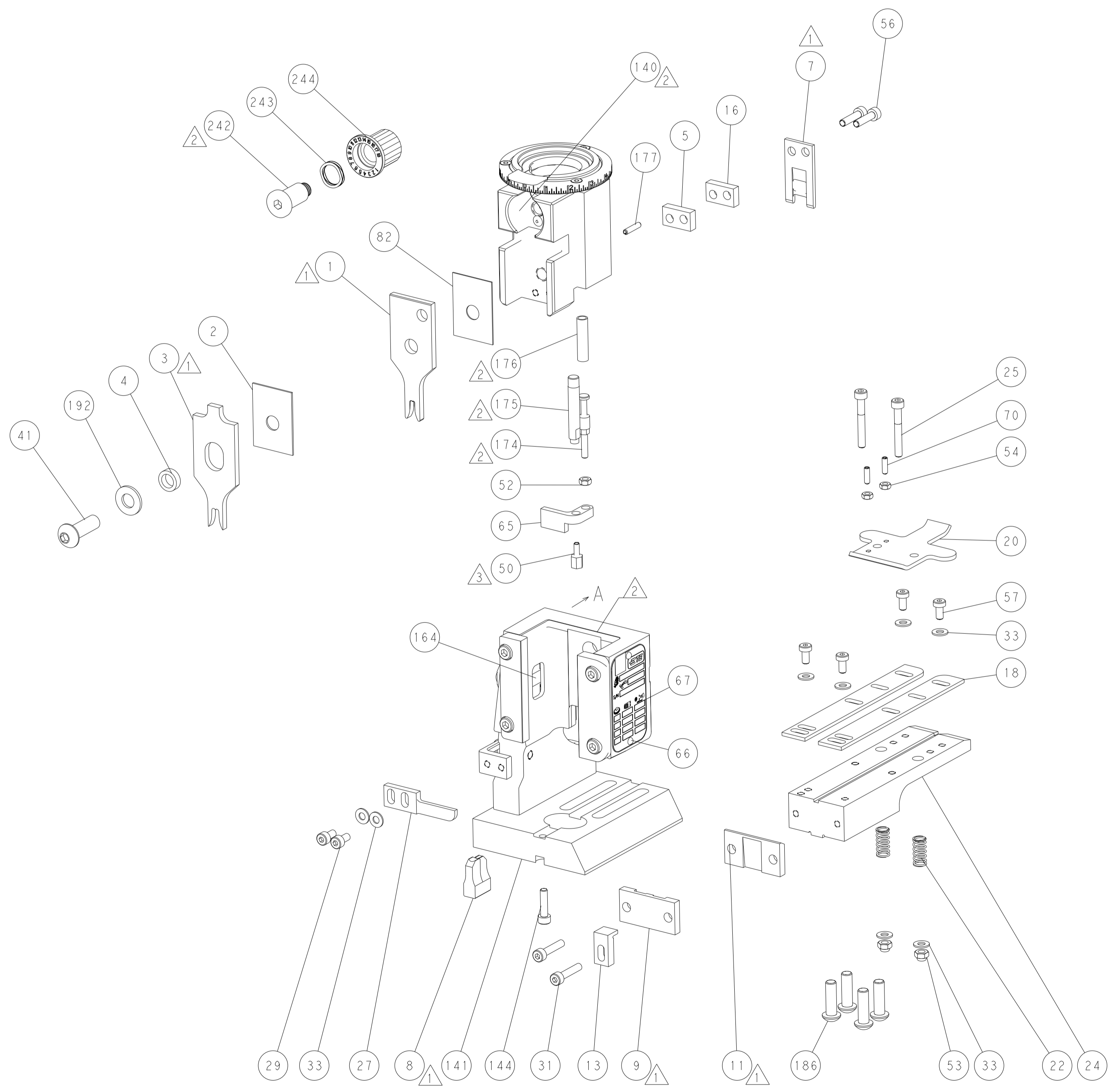

FEED SPRING SETTING POSITION
 DETAIL A

CAM POSITION

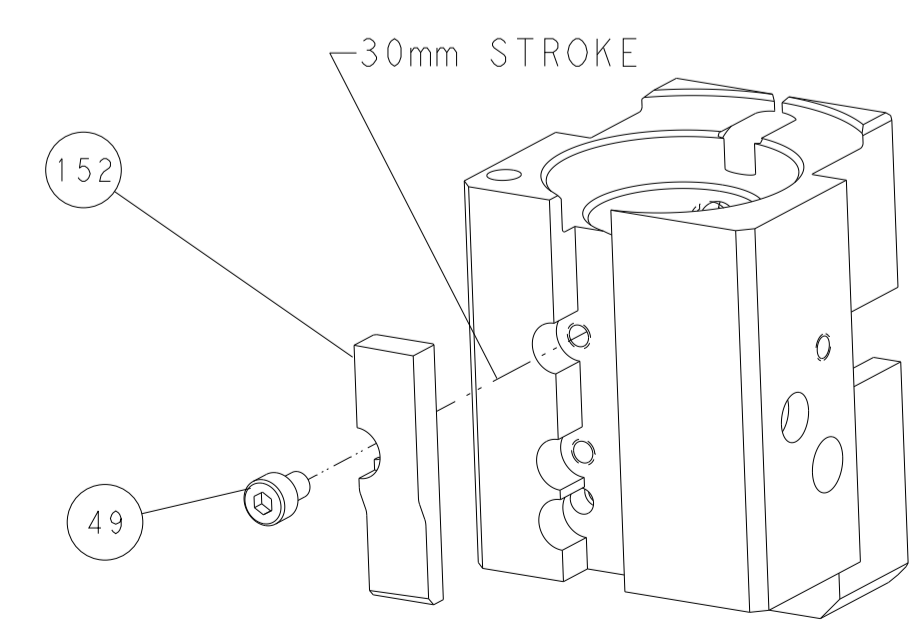

AIR FEED

PACIFIC VERSION
 Shown on sheets 3 of 4 & 4 of 4
 (Atlantic version shown on sheets 1 of 4 & 2 of 4)

<small>THIS DRAWING IS A CONTROLLED DOCUMENT FOR TYCO ELECTRONICS CORPORATION. IT IS THE PROPERTY OF COMPANY AND IS NOT TO BE REPRODUCED OR TRANSMITTED IN ANY FORM OR BY ANY MEANS, ELECTRONIC OR MECHANICAL, INCLUDING PHOTOCOPYING, RECORDING, OR BY ANY INFORMATION STORAGE AND RETRIEVAL SYSTEM, WITHOUT THE WRITTEN PERMISSION OF TYCO ELECTRONICS CORPORATION.</small>		DWN C. CHEN 28MAR2012 CHK S. XI 28MAR2012 APVD J. CRUZ 28MAR2012	NAME Ocean End Feed Applicator
DIMENSIONS: mm 	TOLERANCES UNLESS OTHERWISE SPECIFIED: 0 PLC ± 1 PLC ± 2 PLC ± 3 PLC ± 4 PLC ± ANGLES ± FINISH	SIZE A1 CAGE CODE 00779 DRAWING NO. C=2150255	RESTRICTED TO -
MATERIAL: -		WEIGHT: -	SCALE: 1:1 SHEET: 4 OF 4 REV: B