

### FEATURES

**Initial accuracy:**  $\pm 5$  mV maximum,  $\pm 0.27\%$  maximum  
**Low temperature coefficient:** 25 ppm/ $^{\circ}\text{C}$  maximum  
**Load regulation:** 100 ppm/mA  
**Line regulation:** 25 ppm/V  
**Low supply headroom:** 0.6 V  
**Wide operating range:** ( $V_{\text{OUT}} + 0.6\text{ V}$ ) to 15 V  
**Low power:** 120  $\mu\text{A}$  maximum  
**Shutdown to less than 3  $\mu\text{A}$  maximum**  
**Output current:** 5 mA  
**Wide temperature range:**  $0^{\circ}\text{C}$  to  $70^{\circ}\text{C}$   
**Tiny 5-lead SOT-23 package**

### APPLICATIONS

**Battery-powered instrumentation**  
**Portable medical instruments**  
**Data acquisition systems**  
**Industrial process control systems**  
**Fault protection critical systems**

### GENERAL DESCRIPTION

The ADR318<sup>1</sup> is a precision 1.8 V band gap voltage reference featuring high accuracy, high stability, and low power consumption in a tiny footprint. Patented temperature drift curvature correction techniques minimize nonlinearity of the voltage change with temperature. The wide operating range and low power consumption with additional shutdown capability make the part ideal for battery-powered applications. The  $V_{\text{OUT(SENSE)}}$  pin enables greater accuracy by supporting full Kelvin operation in PCBs employing thin or long traces.

The ADR318 is a low dropout voltage (LDV) device that provides a stable output voltage from supplies as low as 600 mV

### PIN CONFIGURATION

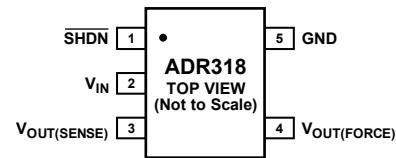

Figure 1. 5-Lead SOT-23

above the output voltage. This device is specified over the industrial operating range of  $0^{\circ}\text{C}$  to  $70^{\circ}\text{C}$ , and is available in a tiny 5-lead SOT-23 package.

The combination of  $V_{\text{OUT(SENSE)}}$  and shutdown functions also enables a number of unique applications, combining precision reference/regulation with fault decision and overcurrent protection.

See the Applications section for details.

<sup>1</sup> Protected by U.S. Patent No. 5,969,657; other patents pending.

#### Rev. A

Information furnished by Analog Devices is believed to be accurate and reliable. However, no responsibility is assumed by Analog Devices for its use, nor for any infringements of patents or other rights of third parties that may result from its use. Specifications subject to change without notice. No license is granted by implication or otherwise under any patent or patent rights of Analog Devices. Trademarks and registered trademarks are the property of their respective owners.

## TABLE OF CONTENTS

Features .....	1	Theory of Operation .....	9
Applications.....	1	Device Power Dissipation Considerations.....	9
Pin Configuration.....	1	Shutdown Mode Operation .....	9
General Description .....	1	Applications.....	10
Revision History .....	2	Basic Voltage Reference Connection .....	10
Specifications.....	3	Precision Negative Voltage Reference Without Precision	
Electrical Characteristics .....	3	Resistors.....	10
Absolute Maximum Ratings.....	4	General-Purpose Current Source .....	10
Thermal Resistance .....	4	High Power Performance with Current Limit .....	10
ESD Caution.....	4	Outline Dimensions .....	12
Typical Performance Characteristics .....	5	Ordering Guide .....	12
Terminology .....	8		

## REVISION HISTORY

### 10/06—Rev. 0 to Rev. A

Updated Format .....	Universal
Changes to Ordering Guide .....	12
Updated Outline Dimensions .....	12

### 1/03—Revision 0: Initial Version

## SPECIFICATIONS

### ELECTRICAL CHARACTERISTICS

$T_A = T_{MIN}$  to  $T_{MAX}$ ,  $V_{IN} = 5$  V, unless otherwise noted<sup>1</sup>.

Table 1.

Parameter	Symbol	Conditions	Min	Typ	Max	Unit
Initial Accuracy	$V_O$		1.795	1.8	1.802	V
Initial Accuracy Error	$V_{OERR}$		-0.27		+0.27	%
Temperature Coefficient	$TC_{VO}$	0°C to 70°C		5	25	ppm/°C
Minimum Supply Voltage Headroom	$V_{IN} - V_{OUT}$		600			mV
Line Regulation	$\Delta V_{OUT}/\Delta V_{IN}$	$V_{IN} = 2.5$ V to 15 V, 0°C < $T_A$ < 70°C		10	25	ppm/V
Load Regulation	$\Delta V_{OUT}/\Delta I_{LOAD}$	$V_{IN} = 3$ V, $I_{LOAD} = 0$ mA to 5 mA, 0°C < $T_A$ < 70°C			100	ppm/mA
Quiescent Current	$I_{SY}$	No load 0°C < $T_A$ < 70°C		100	120 140	$\mu$ A $\mu$ A
Voltage Noise	$e_N$	0.1 Hz to 10 Hz		5		$\mu$ V p-p
Turn-On Settling Time	$t_R$			20		$\mu$ s
Long-Term Stability <sup>2</sup>	$\Delta V_{OUT}$			50		ppm/1000 hours
Output Voltage Hysteresis	$V_{O\_HYS}$			40		ppm
Ripple Rejection Ratio	RRR	$f_{IN} = 60$ Hz		85		dB
Short Circuit to Ground	$I_{SC}$	$V_{IN} = 5.0$ V $V_{IN} = 15.0$ V		25 30		mA mA
Shutdown Supply Current	$I_{SHDN}$				3	$\mu$ A
Shutdown Logic Input Current	$I_{LOGIC}$				500	nA
Shutdown Logic Low	$V_{INL}$				0.8	V
Shutdown Logic High	$V_{INH}$		2.4			V

<sup>1</sup>  $T_{MIN} = 0^\circ\text{C}$ ,  $T_{MAX} = 70^\circ\text{C}$ .

<sup>2</sup> The long-term stability specification is noncumulative. The drift in subsequent 1000-hour periods is significantly lower than in the first 1000-hour period.

## ABSOLUTE MAXIMUM RATINGS

At 25°C, unless otherwise noted.

**Table 2.**

Parameter	Rating
Supply Voltage	18 V
Output Short-Circuit Duration to GND	Observe derating curves
Storage Temperature Range: RJ-5 Package	-65°C to +125°C
Operating Temperature Range	0°C to 70°C
Junction Temperature Range: RJ-5 Package	-65°C to +150°C
Lead Temperature Range (Soldering, 60 sec)	300°C

Stresses above those listed under Absolute Maximum Ratings may cause permanent damage to the device. This is a stress rating only; functional operation of the device at these or any other conditions above those indicated in the operational section of this specification is not implied. Exposure to absolute maximum rating conditions for extended periods may affect device reliability.

### THERMAL RESISTANCE

$\theta_{JA}$  is specified for the worst-case conditions, that is, a device soldered in a circuit board for surface-mount packages.

**Table 3. Thermal Resistance**

Package Type	$\theta_{JA}$	$\theta_{JC}$	Unit
5-Lead SOT-23 (RJ-5)	230	146	°C/W

### ESD CAUTION



**ESD (electrostatic discharge) sensitive device.** Charged devices and circuit boards can discharge without detection. Although this product features patented or proprietary protection circuitry, damage may occur on devices subjected to high energy ESD. Therefore, proper ESD precautions should be taken to avoid performance degradation or loss of functionality.

# TYPICAL PERFORMANCE CHARACTERISTICS

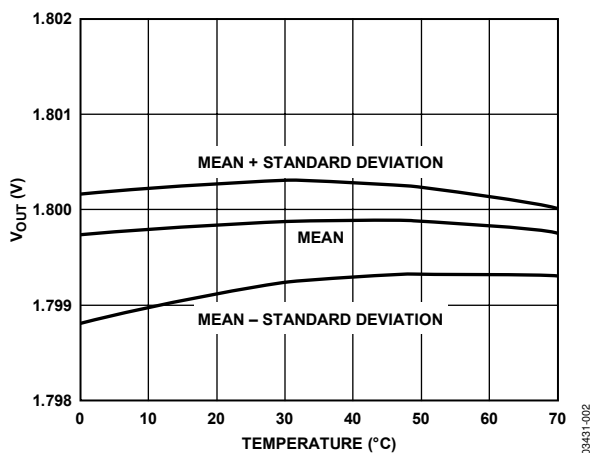

Figure 2. Typical Output Voltage vs. Temperature

03431-002

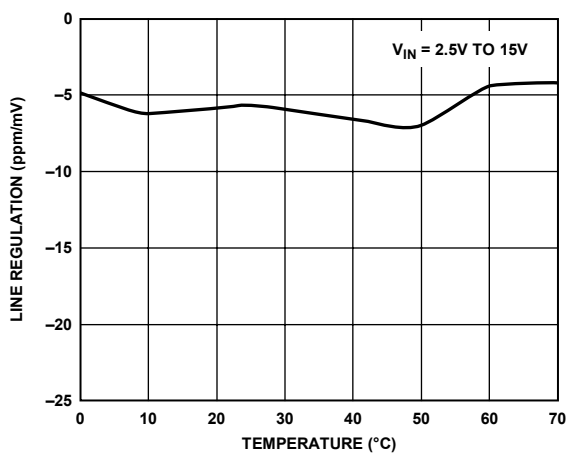

Figure 5. Line Regulation vs. Temperature

03431-005

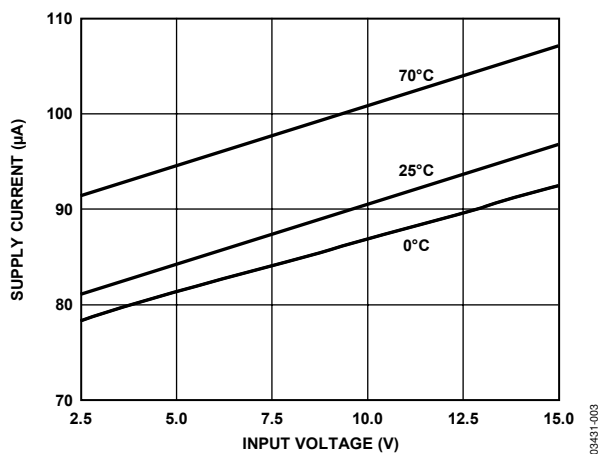

Figure 3. Supply Current vs. Input Voltage

03431-003

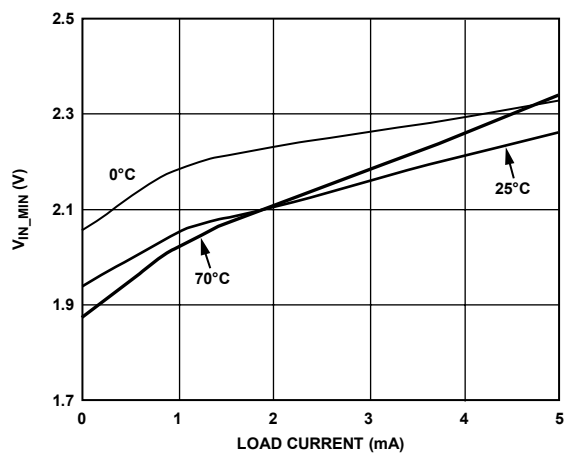

Figure 6. Minimum Input Voltage vs. Load Current

03431-006

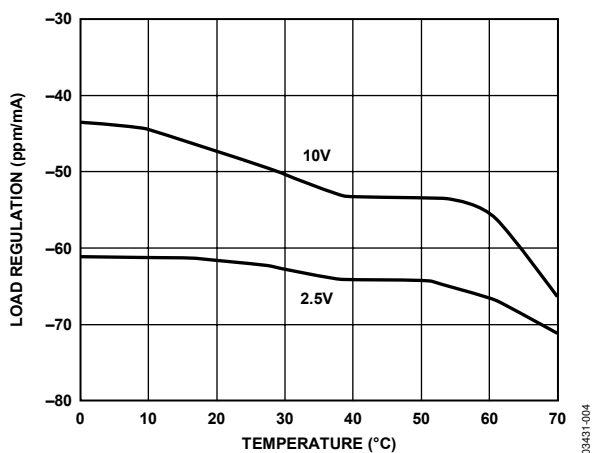

Figure 4. Load Regulation vs. Temperature

03431-004

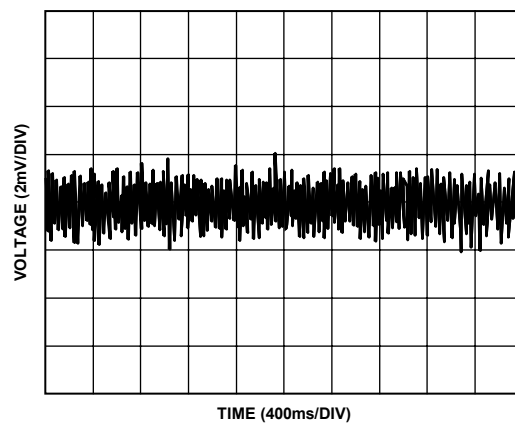
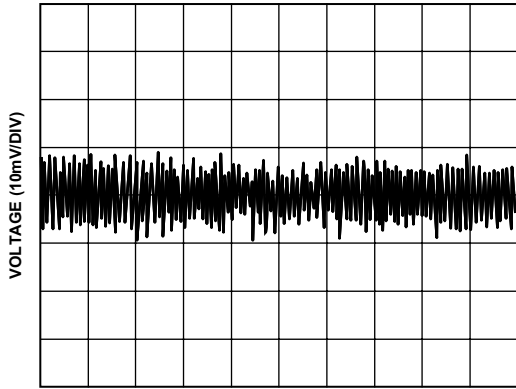

Figure 7. Typical Output Voltage Noise 0.1 Hz to 10 Hz

03431-007



TIME (10ms/DIV)

03431-008

Figure 8. Typical Output Voltage Noise 10 Hz to 10 kHz

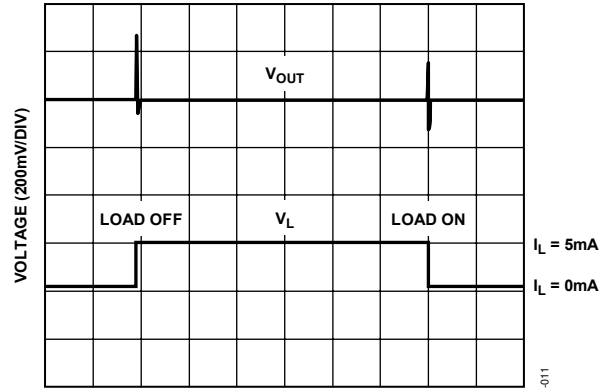

TIME (200µs/DIV)

03431-011

Figure 11. Load Transient Response,  $C_L = 0 \text{ nF}$

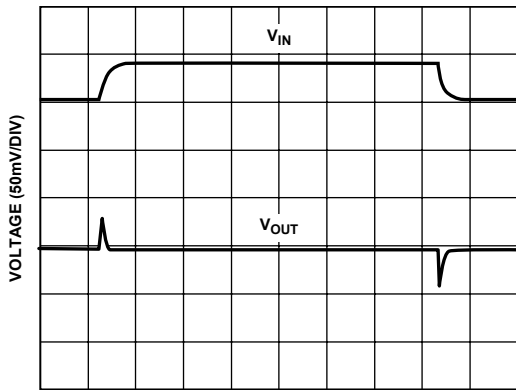

TIME (40µs/DIV)

03431-009

Figure 9. Line Transient Response,  $C_{\text{BYPASS}} = 0 \mu\text{F}$

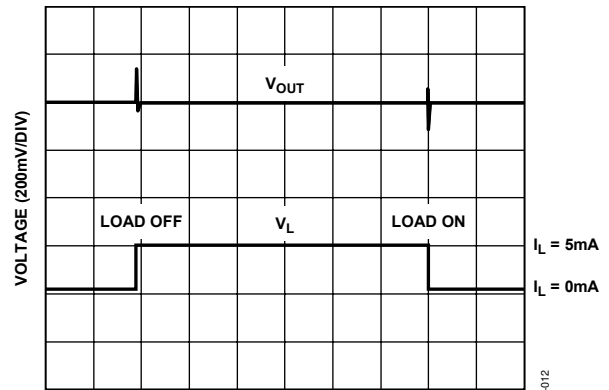

TIME (200µs/DIV)

03431-012

Figure 12. Load Transient Response,  $C_L = 1 \text{ nF}$

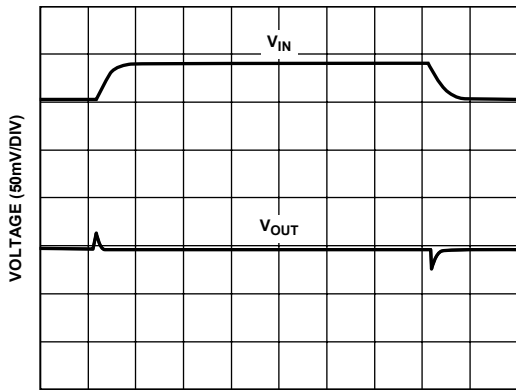

TIME (40µs/DIV)

03431-010

Figure 10. Line Transient Response,  $C_{\text{BYPASS}} = 0.1 \mu\text{F}$

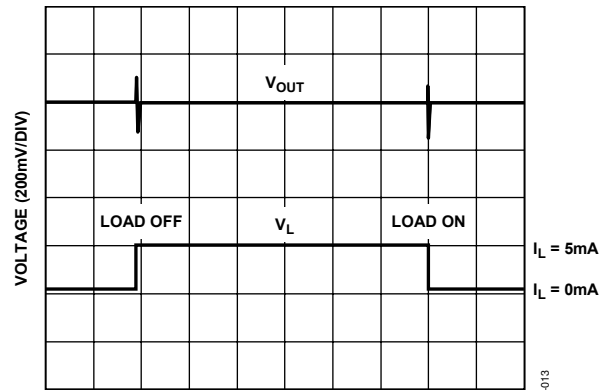

TIME (200µs/DIV)

03431-013

Figure 13. Load Transient Response,  $C_L = 100 \text{ nF}$

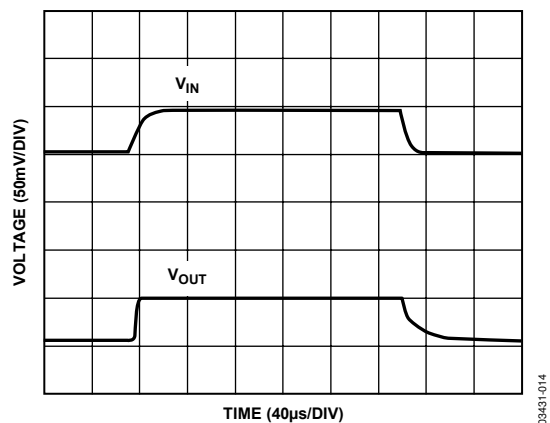

Figure 14. Turn-On/Turn-Off Response at 5 V,  $R_{LOAD} = 1.8\text{ k}\Omega$

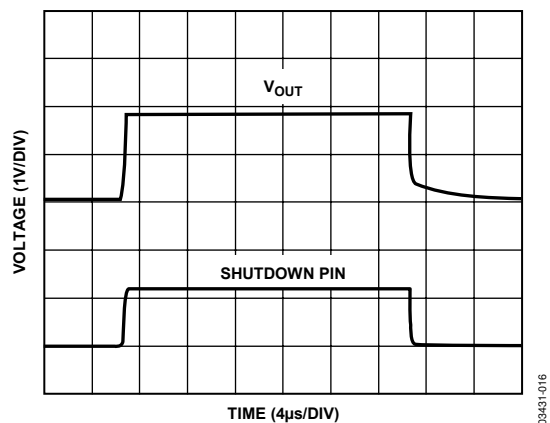

Figure 16. Shutdown Pin Response

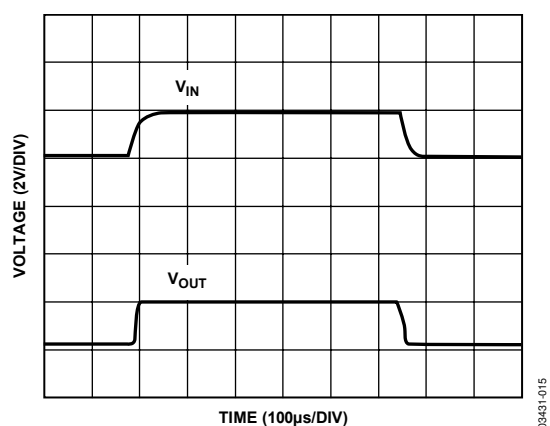

Figure 15. Turn-On/Turn-Off Response at 5 V,  $R_{LOAD} = 1.8\text{ k}\Omega$ ,  $C_{BYPASS} = 0.1\text{ }\mu\text{F}$

## TERMINOLOGY

### Temperature Coefficient

Temperature coefficient is the change of output voltage with respect to operating temperature changes, normalized by the output voltage at 25°C. This parameter is expressed in ppm/°C, and can be determined with the following equation:

$$TCV_o \left[ \frac{\text{ppm}}{^\circ\text{C}} \right] = \frac{V_o(T_2) - V_o(T_1)}{V_o(25^\circ\text{C}) \times (T_2 - T_1)} \times 10^6 \quad (1)$$

where:

$V_o(25^\circ\text{C}) = V_o$  at 25°C.

$V_o(T_1) = V_o$  at Temperature 1.

$V_o(T_2) = V_o$  at Temperature 2.

### Long-Term Stability

Long-term stability is the typical shift of output voltage at 25°C on a sample of parts subjected to a test of 1000 hours at 25°C.

$$\Delta V_o = V_o(t_0) - V_o(t_1)$$

$$\Delta V_o [\text{ppm}] = \frac{V_o(t_0) - V_o(t_1)}{V_o(t_0)} \times 10^6 \quad (2)$$

where:

$V_o(t_0) = V_o$  at 25°C at Time 0.

$V_o(t_1) = V_o$  at 25°C after 1000 hours of operation at 25°C.

### Thermal Hysteresis

Thermal hysteresis is the change of output voltage after the device is cycled through temperature from +25°C to -40°C to +125°C and back to +25°C. This is a typical value from a sample of parts put through such a cycle.

$$V_{O\_HYS} = V_o(25^\circ\text{C}) - V_{O\_TC}$$

$$V_{O\_HYS} [\text{ppm}] = \frac{V_o(25^\circ\text{C}) - V_{O\_TC}}{V_o(25^\circ\text{C})} \times 10^6 \quad (3)$$

where:

$V_o(25^\circ\text{C}) = V_o$  at 25°C.

$V_{O\_TC} = V_o$  at 25°C after temperature cycle at +25°C to -40°C to +125°C and back to +25°C.



## THEORY OF OPERATION

Band gap references are the high performance solution for low supply voltage and low power voltage reference applications, and the ADR318 is no exception. The uniqueness of this lies in its architecture. By observing Figure 17, the ideal zero temperature coefficient (TC) band gap voltage is referenced to the output, not to ground. Therefore, if noise exists on the ground line, it is greatly attenuated on  $V_{OUT}$ . The band gap cell consists of the PNP pair, Q51 and Q52, running at unequal current densities. The difference in voltage base emitter ( $V_{BE}$ ) results in a voltage with a positive TC that is amplified by the ratio of  $2 \times (R58/R54)$ . This proportional-to-absolute temperature (PTAT) voltage, combined with  $V_{BE}$  Q51 and  $V_{BE}$  Q52, produces the stable band gap voltage.

Reduction in band gap curvature is performed by the ratio of the resistors R44 and R59, one of which is linearly temperature dependent. Precision laser-trimming and other patented circuit techniques are used to further enhance the drift performance.

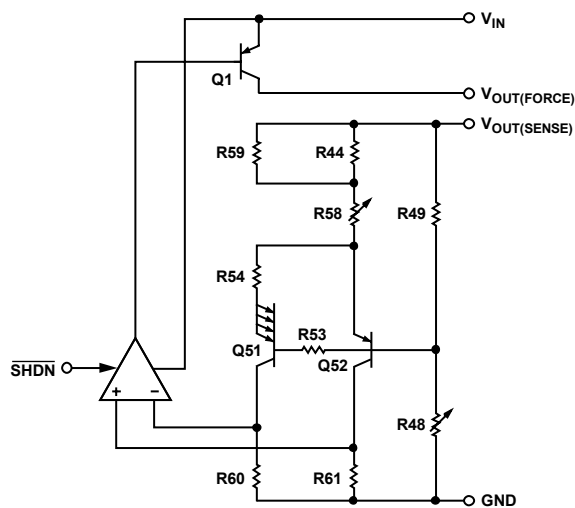

Figure 17. Simplified Schematic

03431-017

## DEVICE POWER DISSIPATION CONSIDERATIONS

The ADR318 is capable of delivering load currents up to 5 mA with an input voltage that ranges from 2.4 V to 15 V. When this device is used in applications with high input voltages, care should be taken to avoid exceeding the specified maximum power dissipation or junction temperature. Doing so results in premature device failure. The following formula should be used to calculate the device's maximum junction temperature or dissipation:

$$P_D = \frac{T_J - T_A}{\theta_{JA}} \quad (4)$$

where:

$T_J$  = the junction temperature.

$T_A$  = the ambient temperatures.

$P_D$  = the device power dissipation.

$\theta_{JA}$  = the device package thermal resistance.

## SHUTDOWN MODE OPERATION

The ADR318 includes a shutdown feature that is TTL/CMOS compatible. A logic low or a 0 V condition on the  $\overline{\text{SHDN}}$  pin is required to turn the device off. During shutdown, the output of the reference becomes a high impedance state where its potential would then be determined by external circuitry. If the shutdown feature is not used, the  $\overline{\text{SHDN}}$  pin should be connected to  $V_{IN}$  (Pin 2).

## APPLICATIONS

### BASIC VOLTAGE REFERENCE CONNECTION

The circuit in Figure 18 illustrates the basic configuration for the ADR318. Decoupling capacitors are not required for circuit stability. The ADR318 is capable of driving capacitive loads from 0  $\mu$ F to 10  $\mu$ F. However, a 0.1  $\mu$ F ceramic output capacitor is recommended to absorb and deliver the charge as is required by a dynamic load.

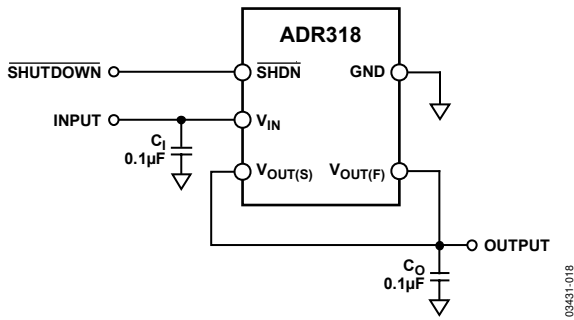

Figure 18. Voltage Reference Connection

### PRECISION NEGATIVE VOLTAGE REFERENCE WITHOUT PRECISION RESISTORS

A negative reference can be easily generated by combining the ADR318 with an op amp. Figure 19 shows this simple negative reference configuration.  $V_{OUT(F)}$  and  $V_{OUT(S)}$  are at virtual ground and therefore the negative reference can be taken directly from the output of the op amp. The op amp should be a dual-supply, low offset, rail-to-rail amplifier, such as the OP1177.

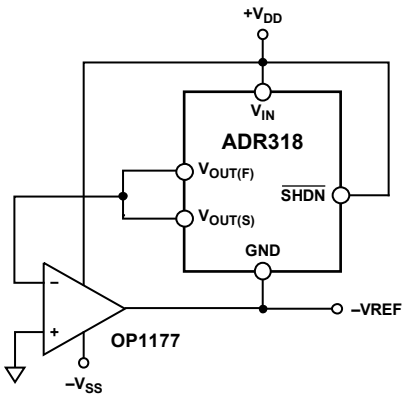

Figure 19. Negative Reference

### GENERAL-PURPOSE CURRENT SOURCE

Many times in low power applications, the need arises for a precision current source that can operate on low supply voltages. As shown in Figure 20, the ADR318 can be configured as a precision current source. The illustrated circuit configuration is a floating current source with a grounded load. The reference output voltage is bootstrapped across  $R_1$  that sets the output current into the load. With this configuration, circuit precision is maintained for load currents in the range of the reference supply current, typically 90 mA, to approximately 5 mA. The supply current is a function of  $I_{SET}$  and increases slightly at a given  $I_{SET}$ .

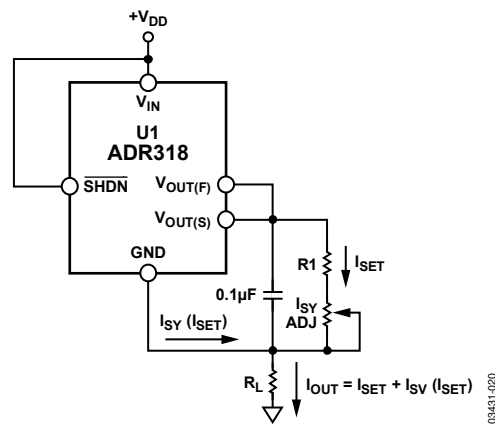

Figure 20. General-Purpose Current Source

### HIGH POWER PERFORMANCE WITH CURRENT LIMIT

In some cases, the user may want higher output current delivered to a load and still achieve better than 0.5% accuracy out of the ADR318. The accuracy for a reference is normally specified with no load (see the Specifications section). However, the output voltage changes with the load current.

The circuit in Figure 21 provides high current without compromising the accuracy of the ADR318. The power bipolar junction transistor (BJT) Q1 provides the required current, up to 1 A. The ADR318 delivers the base drive to Q1 through the force pin. The sense pin of the ADR318 is a regulated output and is connected to the load.

The transistor Q2 protects Q1 during short-circuit limit faults by robbing its base drive. The maximum current is  $I_{L, MAX} = 0.6 V/R_S$ .

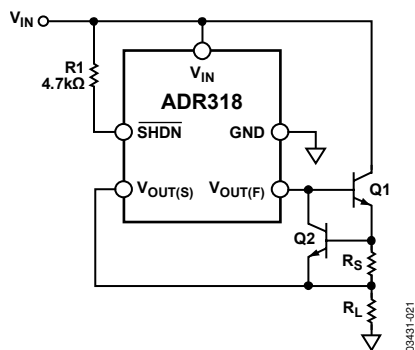

Figure 21. High Power Performance with Current Limit

A similar circuit function can also be achieved using the Darlington transistor configuration, as shown in Figure 22.

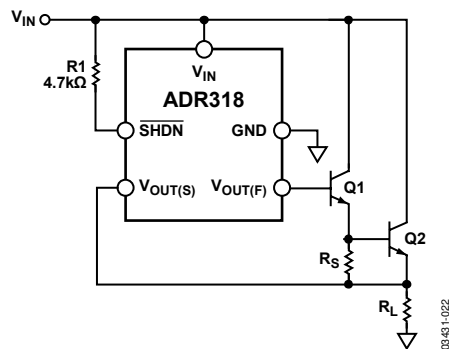
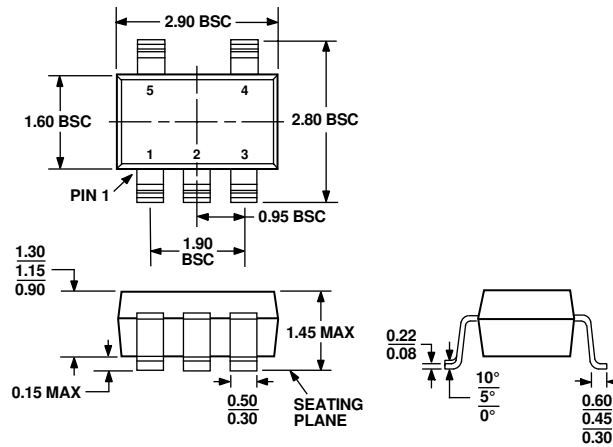

Figure 22. High Output Current with Darlington Drive Configuration

OUTLINE DIMENSIONS



COMPLIANT TO JEDEC STANDARDS MO-178-AA

Figure 23. 5-Lead Small Outline Transistor Package [SOT-23] (RJ-5)

Dimensions shown in millimeters

ORDERING GUIDE

Model	Temperature Range	Package Description	Package Option	Branding	Output Voltage	Ordering Quantity
ADR318ARJ-R2	0°C to 70°C	5-Lead SOT-23	RJ-5	REA	1.800 V	250
ADR318ARJ-REEL	0°C to 70°C	5-Lead SOT-23	RJ-5	REA	1.800 V	10,000
ADR318ARJ-REEL7	0°C to 70°C	5-Lead SOT-23	RJ-5	REA	1.800 V	3,000
ADR318ARJZ-REEL7 <sup>1</sup>	0°C to 70°C	5-Lead SOT-23	RJ-5	L28	1.800 V	3,000

<sup>1</sup> Z = Pb-free part.