

# MAX211

## 5-V MULTICHANNEL RS-232 LINE DRIVER/RECEIVER WITH $\pm 15$ -kV ESD PROTECTION

SLLS567E – MAY 2003 – REVISED JANUARY 2004

- **RS-232 Bus-Pin ESD Protection Exceeds  $\pm 15$  kV Using Human-Body Model (HBM)**
- **Meets or Exceeds the Requirements of TIA/EIA-232-F and ITU v.28 Standards**
- **Operates at 5-V  $V_{CC}$  Supply**
- **Four Drivers and Five Receivers**
- **Operates Up To 120 kbit/s**
- **Low Supply Current in Shutdown Mode . . . 1  $\mu$ A Typical**
- **External Capacitors . . .  $4 \times 0.1 \mu$ F**
- **Latch-Up Performance Exceeds 100 mA Per JESD 78, Class II**
- **Applications**
  - Battery-Powered Systems, PDAs, Notebooks, Laptops, Palmtop PCs, and Hand-Held Equipment

DB OR DW PACKAGE  
(TOP VIEW)

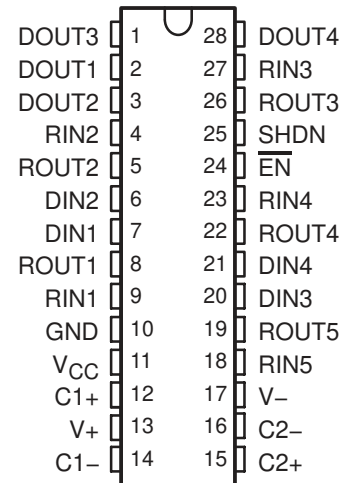

### description/ordering information

The MAX211 device consists of four line drivers, five line receivers, and a dual charge-pump circuit with  $\pm 15$ -kV ESD protection pin to pin (serial-port connection pins, including GND). The device meets the requirements of TIA/EIA-232-F and provides the electrical interface between an asynchronous communication controller and the serial-port connector. The charge pump and four small external capacitors allow operation from a single 5-V supply. The devices operate at data signaling rates up to 120 kbit/s and a maximum of 30-V/ $\mu$ s driver output slew rate.

The MAX211 has both shutdown (SHDN) and enable control ( $\overline{EN}$ ). In shutdown mode, the charge pumps are turned off,  $V_+$  is pulled down to  $V_{CC}$ ,  $V_-$  is pulled to GND, and the transmitter outputs are disabled. This reduces supply current typically to 1  $\mu$ A.  $\overline{EN}$  is used to put the receiver outputs into the high-impedance state to allow wired-OR connection of two RS-232 ports. It has no effect on the RS-232 drivers or the charge pumps.

### ORDERING INFORMATION

$T_A$	PACKAGE†		ORDERABLE PART NUMBER	TOP-SIDE MARKING
0°C to 70°C	SOIC (DW)	Tube of 20	MAX211CDW	MAX211C
		Reel of 1000	MAX211CDWR	
	SSOP (DB)	Tube of 50	MAX211CDB	MAX211C
		Reel of 2000	MAX211CDBR	
–40°C to 85°C	SOIC (DW)	Tube of 20	MAX211IDW	MAX211I
		Reel of 1000	MAX211IDWR	
	SSOP (DB)	Tube of 50	MAX211IDB	MAX211I
		Reel of 2000	MAX211IDBR	

† Package drawings, standard packing quantities, thermal data, symbolization, and PCB design guidelines are available at [www.ti.com/sc/package](http://www.ti.com/sc/package).



Please be aware that an important notice concerning availability, standard warranty, and use in critical applications of Texas Instruments semiconductor products and disclaimers thereto appears at the end of this data sheet.

PRODUCTION DATA information is current as of publication date. Products conform to specifications per the terms of Texas Instruments standard warranty. Production processing does not necessarily include testing of all parameters.



POST OFFICE BOX 655303 • DALLAS, TEXAS 75265

Copyright © 2004, Texas Instruments Incorporated

**MAX211**  
**5-V MULTICHANNEL RS-232 LINE DRIVER/RECEIVER**  
**WITH  $\pm 15$ -kV ESD PROTECTION**

SLLS567E – MAY 2003 – REVISED JANUARY 2004

**Function Tables**

INPUTS		DRIVER	RECEIVER	DEVICE STATUS
SHDN	$\overline{\text{EN}}$			
L	L	All active	All active	Normal operation
L	H	All active	Z	Normal operation
H	X	Z	Z	Shutdown

X = don't care, Z = high impedance

**EACH DRIVER**

INPUTS		OUTPUT DOUT	DRIVER STATUS
DIN	SHDN		
L	L	H	Normal operation
H	L	L	
X	H	Z	Powered off

X = don't care, Z = high impedance

**EACH RECEIVER**

INPUTS		OUTPUT ROUT	RECEIVER STATUS
RIN	$\overline{\text{EN}}$		
L	L	H	Normal operation
H	L	L	
X	H	Z	Powered off

X = don't care, Z = high impedance

**MAX211**  
**5-V MULTICHANNEL RS-232 LINE DRIVER/RECEIVER**  
**WITH ±15-kV ESD PROTECTION**

SLLS567E – MAY 2003 – REVISED JANUARY 2004

logic diagram (positive logic)

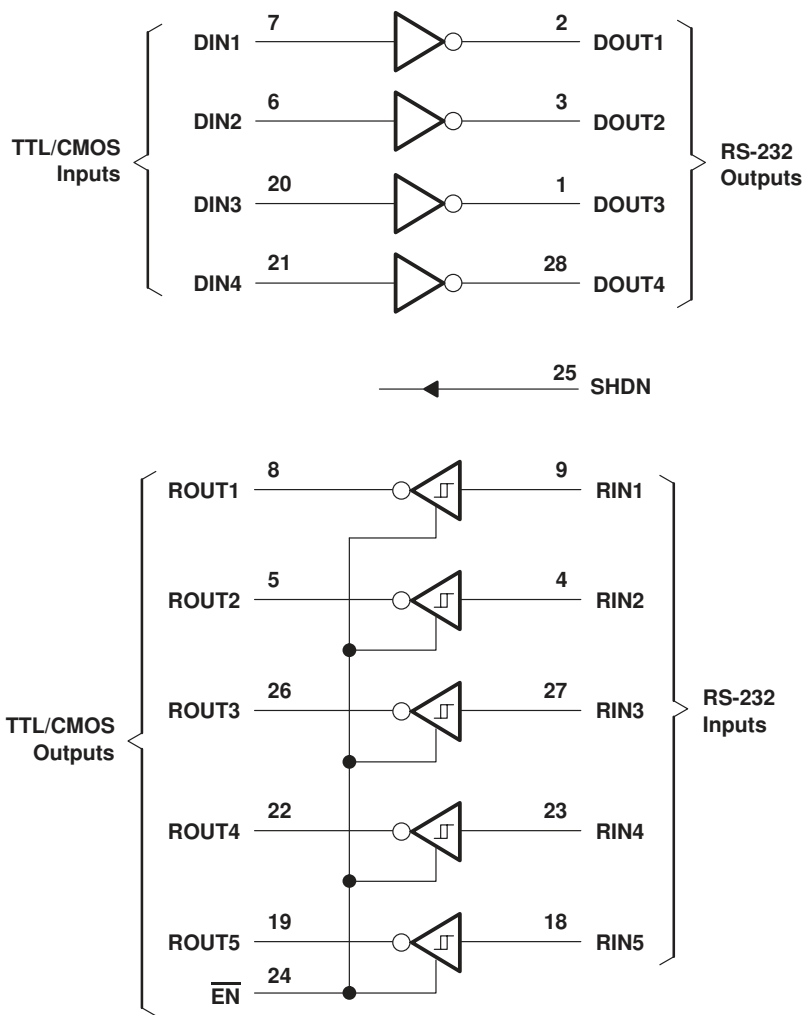

**MAX211**  
**5-V MULTICHANNEL RS-232 LINE DRIVER/RECEIVER**  
**WITH ±15-kV ESD PROTECTION**

SLLS567E – MAY 2003 – REVISED JANUARY 2004

**absolute maximum ratings over operating free-air temperature range (unless otherwise noted)†**

Supply voltage range, $V_{CC}$ (see Note 1)	.....	-0.3 V to 6 V
Positive charge pump voltage range, $V_+$ (see Note 1)	.....	$V_{CC} - 0.3$ V to 14 V
Negative charge pump voltage range, $V_-$ (see Note 1)	.....	0.3 V to -14 V
Input voltage range, $V_I$ : Drivers	.....	-0.3 V to $V_+ + 0.3$ V
Receivers	.....	±30 V
Output voltage range, $V_O$ : Drivers	.....	$V_- - 0.3$ V to $V_+ + 0.3$ V
Receivers	.....	-0.3 V to $V_{CC} + 0.3$ V
Short-circuit duration: DOUT	.....	Continuous
Package thermal impedance, $\theta_{JA}$ (see Notes 2 and 3): DB package	.....	62°C/W
DW package	.....	46°C/W
Operating virtual junction temperature, $T_J$	.....	150°C
Storage temperature range, $T_{stg}$	.....	-65°C to 150°C

† Stresses beyond those listed under “absolute maximum ratings” may cause permanent damage to the device. These are stress ratings only, and functional operation of the device at these or any other conditions beyond those indicated under “recommended operating conditions” is not implied. Exposure to absolute-maximum-rated conditions for extended periods may affect device reliability.

- NOTES: 1. All voltages are with respect to network GND.  
2. Maximum power dissipation is a function of  $T_{J(max)}$ ,  $\theta_{JA}$ , and  $T_A$ . The maximum allowable power dissipation at any allowable ambient temperature is  $P_D = (T_{J(max)} - T_A)/\theta_{JA}$ . Operating at the absolute maximum  $T_J$  of 150°C can affect reliability.  
3. The package thermal impedance is calculated in accordance with JESD 51-7.

**recommended operating conditions (see Note 4 and Figure 4)**

			MIN	NOM	MAX	UNIT
Supply voltage			4.5	5	5.5	V
$V_{IH}$	Driver high-level input voltage	DIN	2			V
	Control high-level input voltage	$\overline{EN}$ , SHDN	2.4			
$V_{IL}$	Driver and control low-level input voltage	DIN, $\overline{EN}$ , SHDN	0.8			V
$V_I$	Driver and control input voltage	DIN, $\overline{EN}$ , SHDN	0	5.5		V
	Receiver input voltage		-30	30		
$T_A$	Operating free-air temperature	MAX211C	0	70		°C
		MAX211I	-40	85		

NOTE 4: Test conditions are C1–C4 = 0.1  $\mu$ F at  $V_{CC} = 5$  V  $\pm$  0.5 V.

**electrical characteristics over recommended ranges of supply voltage and operating free-air temperature (unless otherwise noted) (see Note 4)**

PARAMETER		TEST CONDITIONS		MIN	TYP‡	MAX	UNIT
$I_{CC}$	Supply current	No load,	See Figure 6		14	20	mA
	Shutdown supply current	$T_A = 25^\circ\text{C}$ ,	See Figure 1		1	10	$\mu$ A

‡ All typical values are at  $V_{CC} = 5$  V, and  $T_A = 25^\circ\text{C}$ .

NOTE 4: Test conditions are C1–C4 = 0.1  $\mu$ F at  $V_{CC} = 5$  V  $\pm$  0.5 V.



**MAX211**  
**5-V MULTICHANNEL RS-232 LINE DRIVER/RECEIVER**  
**WITH ±15-kV ESD PROTECTION**

SLLS567E – MAY 2003 – REVISED JANUARY 2004

**DRIVER SECTION**

**electrical characteristics over recommended ranges of supply voltage and operating free-air temperature (unless otherwise noted) (see Note 4 and Figure 4)**

PARAMETER		TEST CONDITIONS	MIN	TYP†	MAX	UNIT
V <sub>OH</sub>	High-level output voltage	DOUT at R <sub>L</sub> = 3 kΩ to GND	5	9		V
V <sub>OL</sub>	Low-level output voltage	DOUT at R <sub>L</sub> = 3 kΩ to GND	-5	-9		V
I <sub>IH</sub>	Driver high-level input current	DIN = V <sub>CC</sub>		15	200	μA
	Control high-level input current	$\overline{\text{EN}}$ , SHDN = V <sub>CC</sub>		3	10	
I <sub>IL</sub>	Driver low-level input current	DIN = 0 V		-15	-200	μA
	Control low-level input current	$\overline{\text{EN}}$ , SHDN = 0 V		-3	-10	
I <sub>OS</sub> ‡	Short-circuit output current	V <sub>CC</sub> = 5.5 V, V <sub>O</sub> = 0 V		±10	±60	mA
r <sub>o</sub>	Output resistance	V <sub>CC</sub> , V+, and V- = 0 V, V <sub>O</sub> = ±2 V	300			Ω

† All typical values are at V<sub>CC</sub> = 5 V, and T<sub>A</sub> = 25°C.

‡ Short-circuit durations should be controlled to prevent exceeding the device absolute power dissipation ratings, and not more than one output should be shorted at a time.

NOTE 4: Test conditions are C1–C4 = 0.1 μF at V<sub>CC</sub> = 5 V ± 0.5 V.

**switching characteristics over recommended ranges of supply voltage and operating free-air temperature (unless otherwise noted) (see Note 4)**

PARAMETER		TEST CONDITIONS	MIN	TYP†	MAX	UNIT
	Maximum data rate	C <sub>L</sub> = 50 pF to 1000 pF, One DOUT switching, R <sub>L</sub> = 3 kΩ to 7 kΩ, See Figure 2	120			kbit/s
t <sub>PLH</sub> (D)	Propagation delay time, low- to high-level output	C <sub>L</sub> = 2500 pF, All drivers loaded, R <sub>L</sub> = 3 kΩ, See Figure 2		2		μs
t <sub>PHL</sub> (D)	Propagation delay time, high- to low-level output	C <sub>L</sub> = 2500 pF, All drivers loaded, R <sub>L</sub> = 3 kΩ, See Figure 2		2		μs
t <sub>sk(p)</sub>	Pulse skew§	C <sub>L</sub> = 150 pF to 2500 pF, R <sub>L</sub> = 3 kΩ to 7 kΩ, See Figure 3		300		ns
SR(tr)	Slew rate, transition region (see Figure 2)	C <sub>L</sub> = 50 pF to 1000 pF, V <sub>CC</sub> = 5 V, R <sub>L</sub> = 3 kΩ to 7 kΩ	3	6	30	V/μs

† All typical values are at V<sub>CC</sub> = 5 V, and T<sub>A</sub> = 25°C.

§ Pulse skew is defined as |t<sub>PLH</sub> – t<sub>PHL</sub>| of each channel of the same device.

NOTE 4: Test conditions are C1–C4 = 0.1 μF at V<sub>CC</sub> = 5 V ± 0.5 V.

**ESD protection**

PIN	TEST CONDITIONS	TYP	UNIT
DOUT, R <sub>IN</sub>	Human-Body Model	±15	kV



**MAX211**  
**5-V MULTICHANNEL RS-232 LINE DRIVER/RECEIVER**  
**WITH ±15-kV ESD PROTECTION**

SLLS567E – MAY 2003 – REVISED JANUARY 2004

**RECEIVER SECTION**

**electrical characteristics over recommended ranges of supply voltage and operating free-air temperature (unless otherwise noted) (see Note 4 and Figure 6)**

PARAMETER		TEST CONDITIONS	MIN	TYP†	MAX	UNIT
V <sub>OH</sub>	High-level output voltage	I <sub>OH</sub> = -1 mA	3.5	V <sub>CC</sub> -0.4 V		V
V <sub>OL</sub>	Low-level output voltage	I <sub>OL</sub> = 1.6 mA			0.4	V
V <sub>IT+</sub>	Positive-going input threshold voltage	V <sub>CC</sub> = 5 V, T <sub>A</sub> = 25°C		1.7	2.4	V
V <sub>IT-</sub>	Negative-going input threshold voltage	V <sub>CC</sub> = 5 V, T <sub>A</sub> = 25°C	0.8	1.2		V
V <sub>hys</sub>	Input hysteresis (V <sub>IT+</sub> - V <sub>IT-</sub> )		0.2	0.5	1	V
r <sub>i</sub>	Input resistance	V <sub>CC</sub> = 5 V, T <sub>A</sub> = 25°C	3	5	7	kΩ
	Output leakage current	$\overline{EN} = V_{CC}$ , 0 ≤ R <sub>OUT</sub> ≤ V <sub>CC</sub>		±0.05	±10	μA

† All typical values are at V<sub>CC</sub> = 5 V, and T<sub>A</sub> = 25°C.

NOTE 4: Test conditions are C1-C4 = 0.1 μF at V<sub>CC</sub> = 5 V ± 0.5 V.

**switching characteristics over recommended ranges of supply voltage and operating free-air temperature (unless otherwise noted) (see Note 4)**

PARAMETER		TEST CONDITIONS	MIN	TYP†	MAX	UNIT
t <sub>PLH</sub> (R)	Propagation delay time, low- to high-level output	C <sub>L</sub> = 150 pF, See Figure 4		0.5	10	μs
t <sub>PHL</sub> (R)	Propagation delay time, high- to low-level output	C <sub>L</sub> = 150 pF, See Figure 4		0.5	10	μs
t <sub>en</sub>	Output enable time	C <sub>L</sub> = 150 pF, R <sub>L</sub> = 1 kΩ, See Figure 5		600		ns
t <sub>dis</sub>	Output disable time	C <sub>L</sub> = 150 pF, R <sub>L</sub> = 1 kΩ, See Figure 5		200		ns
t <sub>sk(p)</sub>	Pulse skew‡	See Figure 3		300		ns

† All typical values are at V<sub>CC</sub> = 5 V, and T<sub>A</sub> = 25°C.

‡ Pulse skew is defined as |t<sub>PLH</sub> - t<sub>PHL</sub>| of each channel of the same device.

NOTE 4: Test conditions are C1-C4 = 0.1 μF, at V<sub>CC</sub> = 5 V ± 0.5 V.



**MAX211**  
**5-V MULTICHANNEL RS-232 LINE DRIVER/RECEIVER**  
**WITH  $\pm 15$ -kV ESD PROTECTION**

SLLS567E - MAY 2003 - REVISED JANUARY 2004

**PARAMETER MEASUREMENT INFORMATION**

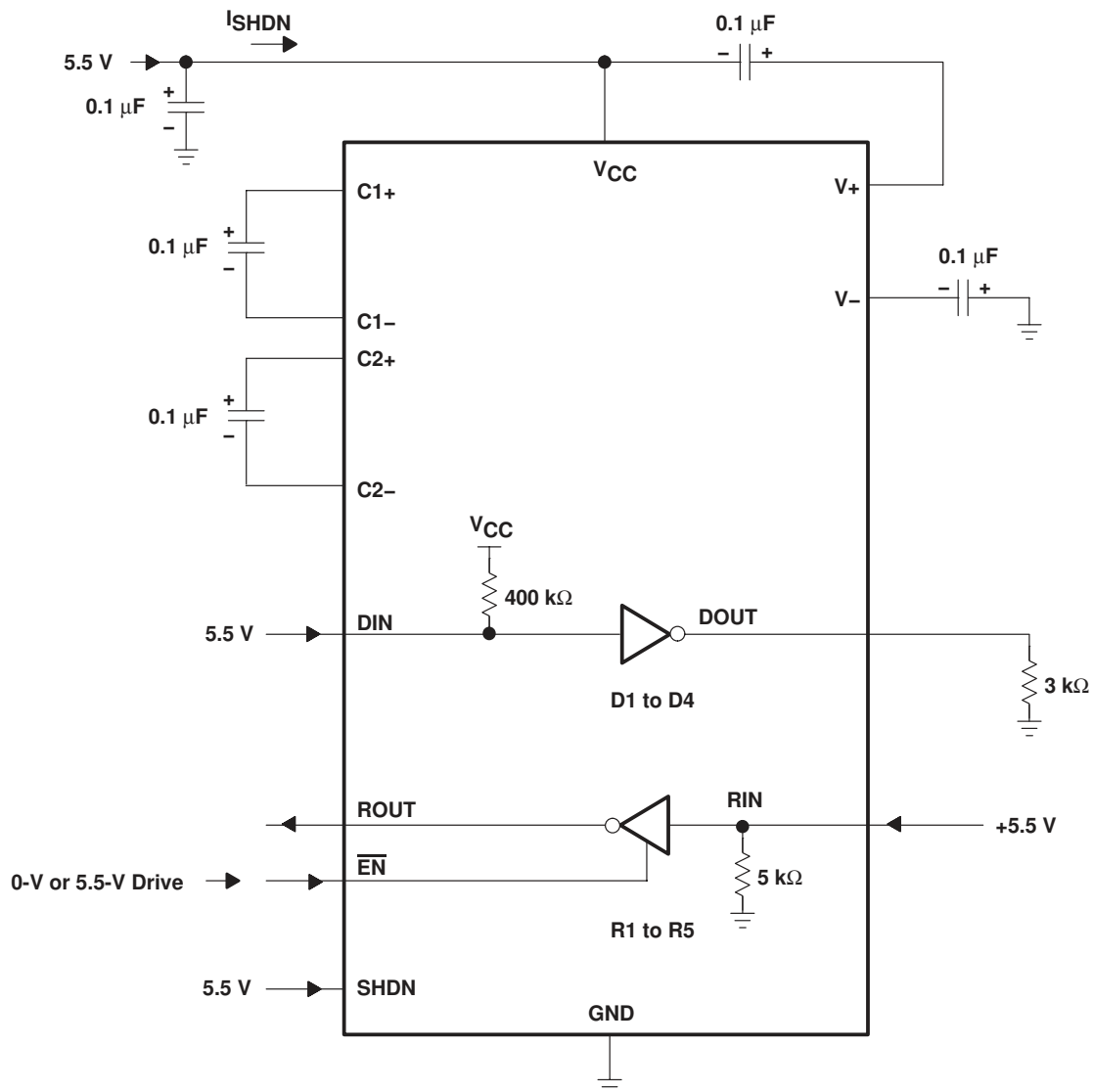
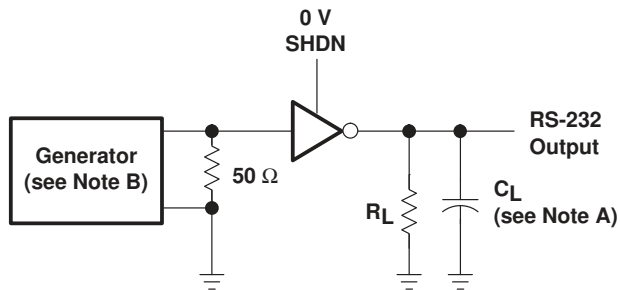

Figure 1. Shutdown Current Test Circuit

**MAX211**  
**5-V MULTICHANNEL RS-232 LINE DRIVER/RECEIVER**  
**WITH ±15-kV ESD PROTECTION**

SLLS567E – MAY 2003 – REVISED JANUARY 2004

**PARAMETER MEASUREMENT INFORMATION**



TEST CIRCUIT

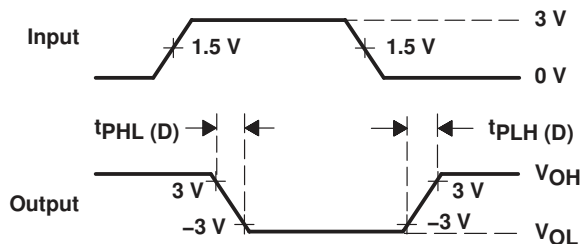

VOLTAGE WAVEFORMS

$$SR(tr) = \frac{6\text{ V}}{t_{PHL(D)} \text{ or } t_{PLH(D)}}$$

- NOTES: A.  $C_L$  includes probe and jig capacitance.  
 B. The pulse generator has the following characteristics: PRR = 120 kbit/s,  $Z_O = 50\ \Omega$ , 50% duty cycle,  $t_r \leq 10\text{ ns}$ ,  $t_f \leq 10\text{ ns}$ .

**Figure 2. Driver Slew Rate and Propagation Delay Times**

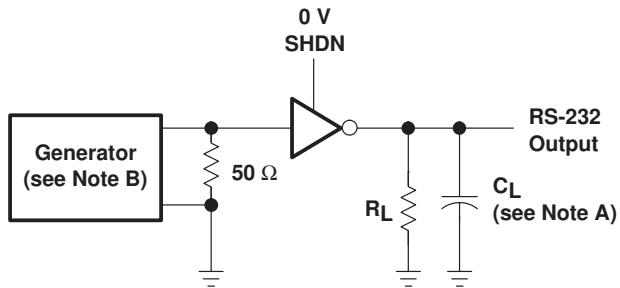

TEST CIRCUIT

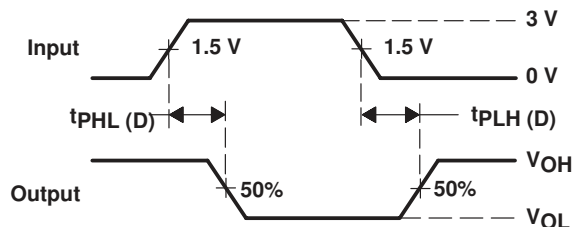

VOLTAGE WAVEFORMS

- NOTES: A.  $C_L$  includes probe and jig capacitance.  
 B. The pulse generator has the following characteristics: PRR = 120 kbit/s,  $Z_O = 50\ \Omega$ , 50% duty cycle,  $t_r \leq 10\text{ ns}$ ,  $t_f \leq 10\text{ ns}$ .

**Figure 3. Driver Pulse Skew**

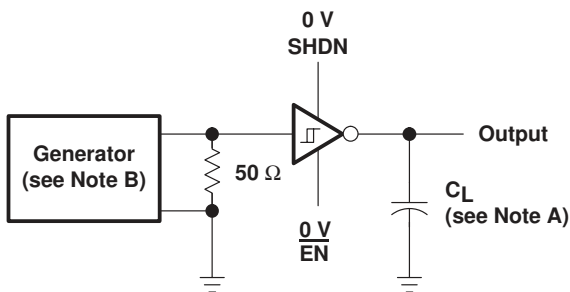

TEST CIRCUIT

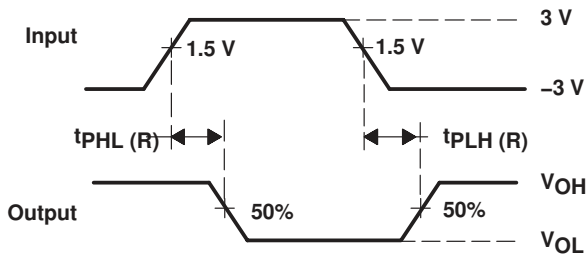

VOLTAGE WAVEFORMS

- NOTES: A.  $C_L$  includes probe and jig capacitance.  
 B. The pulse generator has the following characteristics:  $Z_O = 50\ \Omega$ , 50% duty cycle,  $t_r \leq 10\text{ ns}$ ,  $t_f \leq 10\text{ ns}$ .

**Figure 4. Receiver Propagation Delay Times**



**PARAMETER MEASUREMENT INFORMATION**

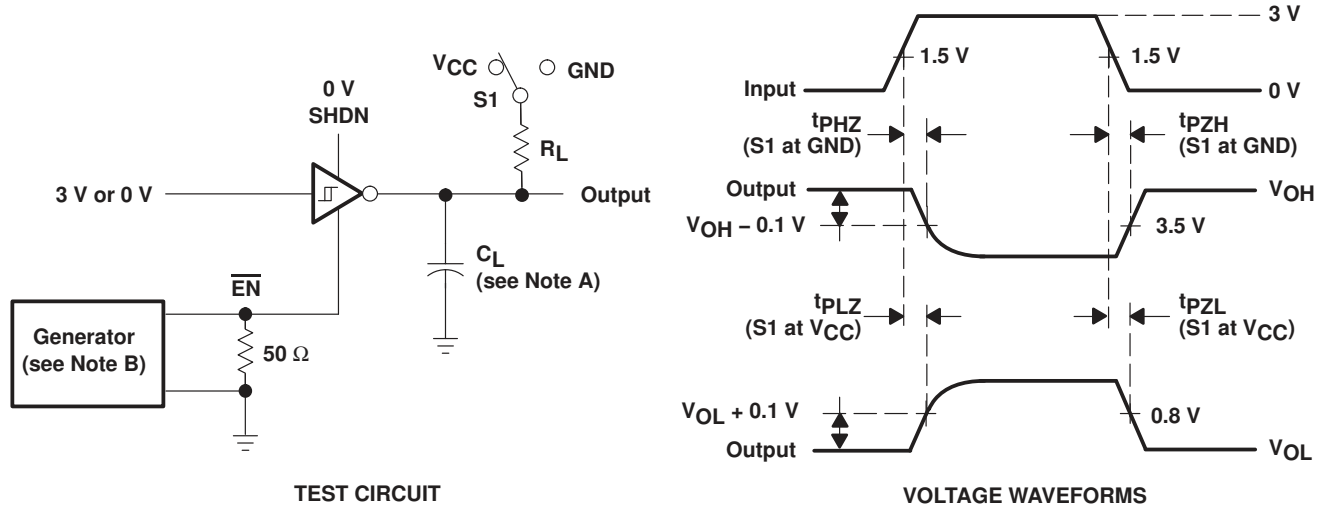

- NOTES: A.  $C_L$  includes probe and jig capacitance.  
 B. The pulse generator has the following characteristics:  $Z_O = 50 \Omega$ , 50% duty cycle,  $t_r \leq 10 \text{ ns}$ ,  $t_f \leq 10 \text{ ns}$ .  
 C.  $t_{PLZ}$  and  $t_{PHZ}$  are the same as  $t_{dis}$ .  
 D.  $t_{PZL}$  and  $t_{PZH}$  are the same as  $t_{en}$ .

**Figure 5. Receiver Enable and Disable Times**

**MAX211**  
**5-V MULTICHANNEL RS-232 LINE DRIVER/RECEIVER**  
**WITH  $\pm 15$ -kV ESD PROTECTION**

SLLS567E – MAY 2003 – REVISED JANUARY 2004

**APPLICATION INFORMATION**

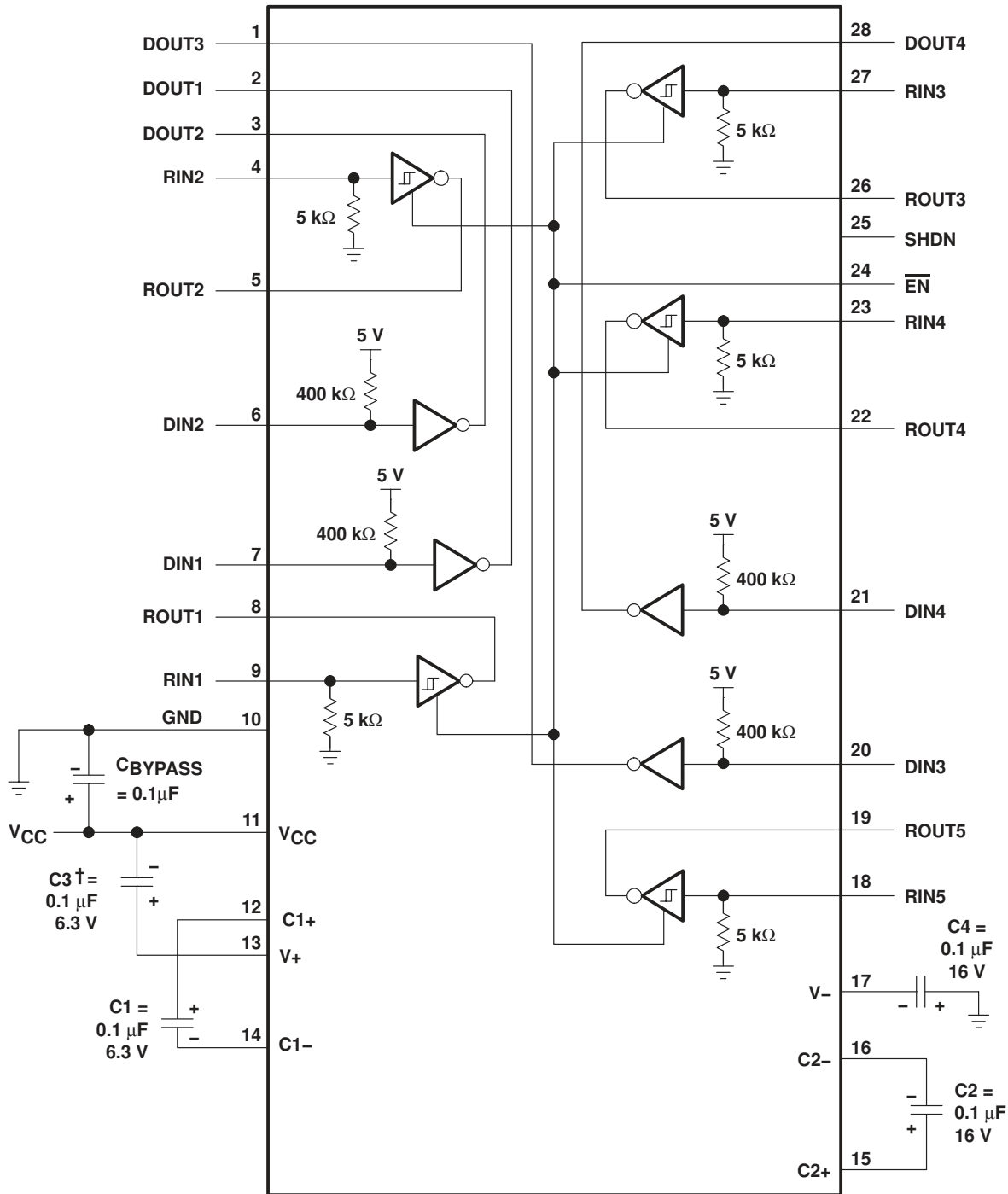

† C3 can be connected to  $V_{CC}$  or GND.

NOTES: A. Resistor values shown are nominal.

B. Nonpolarized ceramic capacitors are acceptable. If polarized tantalum or electrolytic capacitors are used, they should be connected as shown.

**Figure 6. Typical Operating Circuit and Capacitor Values**



## APPLICATION INFORMATION

### capacitor selection

The capacitor type used for C1–C4 is not critical for proper operation. The MAX211 requires 0.1- $\mu\text{F}$  capacitors, although capacitors up to 10  $\mu\text{F}$  can be used without harm. Ceramic dielectrics are suggested for the 0.1- $\mu\text{F}$  capacitors. When using the minimum recommended capacitor values, make sure the capacitance value does not degrade excessively as the operating temperature varies. If in doubt, use capacitors with a larger (e.g., 2 $\times$ ) nominal value. The capacitors' effective series resistance (ESR), which usually rises at low temperatures, influences the amount of ripple on V+ and V–.

Use larger capacitors (up to 10  $\mu\text{F}$ ) to reduce the output impedance at V+ and V–.

Bypass V<sub>CC</sub> to ground with at least 0.1  $\mu\text{F}$ . In applications sensitive to power-supply noise generated by the charge pumps, decouple V<sub>CC</sub> to ground with a capacitor the same size as (or larger than) the charge-pump capacitors (C1–C4).

### electrostatic discharge (ESD) protection

Texas Instruments MAX211 devices have standard ESD protection structures incorporated on the pins to protect against electrostatic discharges encountered during assembly and handling. In addition, the RS232 bus pins (driver outputs and receiver inputs) of these devices have an extra level of ESD protection. Advanced ESD structures were designed to successfully protect these bus pins against ESD discharge of  $\pm 15$  kV when powered down.

### ESD test conditions

ESD testing is stringently performed by TI, based on various conditions and procedures. Please contact TI for a reliability report that documents test setup, methodology, and results.

### Human-Body Model

The Human-Body Model (HBM) of ESD testing is shown in Figure 7. Figure 8 shows the current waveform that is generated during a discharge into a low impedance. The model consists of a 100-pF capacitor charged to the ESD voltage of concern and subsequently discharged into the DUT through a 1.5-k $\Omega$  resistor.

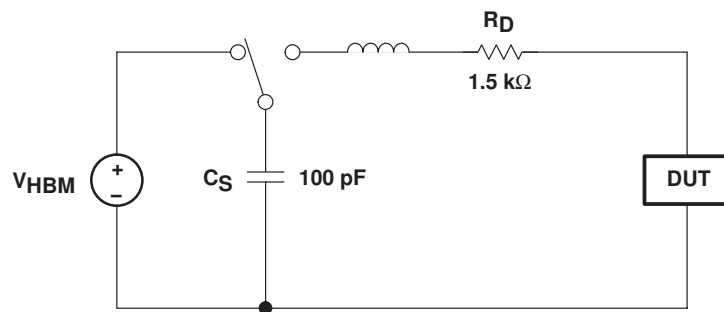
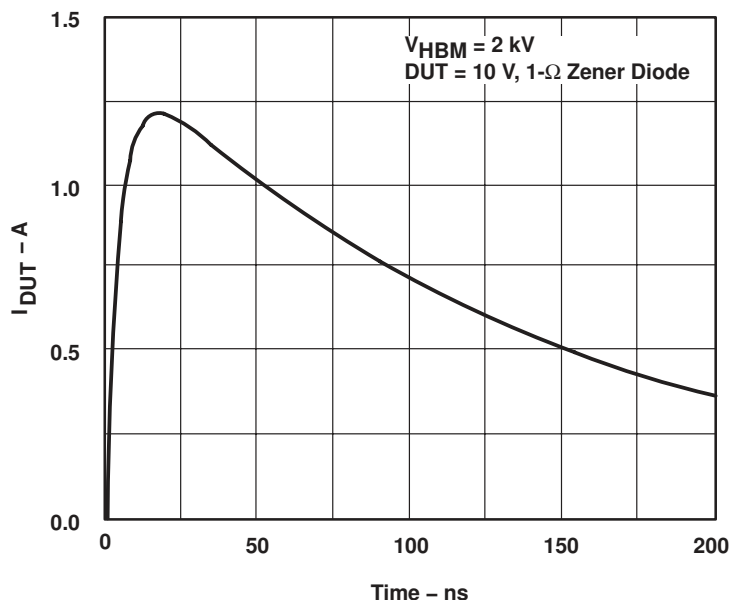

Figure 7. HBM ESD Test Circuit

**MAX211**  
**5-V MULTICHANNEL RS-232 LINE DRIVER/RECEIVER**  
**WITH  $\pm 15$ -kV ESD PROTECTION**

SLLS567E – MAY 2003 – REVISED JANUARY 2004

**APPLICATION INFORMATION**



**Figure 8. Typical HBM Current Waveform**

**Machine Model**

The Machine Model (MM) ESD test applies to all pins, using a 200-pF capacitor with no discharge resistance. The purpose of the MM test is to simulate possible ESD conditions that can occur during the handling and assembly processes of manufacturing. In this case, ESD protection is required for all pins, not just RS-232 pins. However, after PC board assembly, the MM test no longer is as pertinent to the RS-232 pins.

## PACKAGING INFORMATION

Orderable Device	Status (1)	Package Type	Package Drawing	Pins	Package Qty	Eco Plan (2)	Lead finish/ Ball material (6)	MSL Peak Temp (3)	Op Temp (°C)	Device Marking (4/5)	Samples
MAX211CDB	LIFEBUY	SSOP	DB	28	50	RoHS & Green	NIPDAU	Level-1-260C-UNLIM	0 to 70	MAX211C	
MAX211CDBR	LIFEBUY	SSOP	DB	28	2000	RoHS & Green	NIPDAU	Level-1-260C-UNLIM	0 to 70	MAX211C	
MAX211CDW	LIFEBUY	SOIC	DW	28	20	RoHS & Green	NIPDAU	Level-1-260C-UNLIM	0 to 70	MAX211C	
MAX211CDWR	ACTIVE	SOIC	DW	28	1000	RoHS & Green	NIPDAU	Level-1-260C-UNLIM	0 to 70	MAX211C	Samples
MAX211IDB	LIFEBUY	SSOP	DB	28	50	RoHS & Green	NIPDAU	Level-1-260C-UNLIM	-40 to 85	MAX211I	
MAX211IDBR	ACTIVE	SSOP	DB	28	2000	RoHS & Green	NIPDAU	Level-1-260C-UNLIM	-40 to 85	MAX211I	Samples
MAX211IDBRG4	ACTIVE	SSOP	DB	28	2000	RoHS & Green	NIPDAU	Level-1-260C-UNLIM	-40 to 85	MAX211I	Samples
MAX211IDW	LIFEBUY	SOIC	DW	28	20	RoHS & Green	NIPDAU	Level-1-260C-UNLIM	-40 to 85	MAX211I	
MAX211IDWR	ACTIVE	SOIC	DW	28	1000	RoHS & Green	NIPDAU	Level-1-260C-UNLIM	-40 to 85	MAX211I	Samples

(1) The marketing status values are defined as follows:

**ACTIVE:** Product device recommended for new designs.

**LIFEBUY:** TI has announced that the device will be discontinued, and a lifetime-buy period is in effect.

**NRND:** Not recommended for new designs. Device is in production to support existing customers, but TI does not recommend using this part in a new design.

**PREVIEW:** Device has been announced but is not in production. Samples may or may not be available.

**OBSOLETE:** TI has discontinued the production of the device.

(2) **RoHS:** TI defines "RoHS" to mean semiconductor products that are compliant with the current EU RoHS requirements for all 10 RoHS substances, including the requirement that RoHS substance do not exceed 0.1% by weight in homogeneous materials. Where designed to be soldered at high temperatures, "RoHS" products are suitable for use in specified lead-free processes. TI may reference these types of products as "Pb-Free".

**RoHS Exempt:** TI defines "RoHS Exempt" to mean products that contain lead but are compliant with EU RoHS pursuant to a specific EU RoHS exemption.

**Green:** TI defines "Green" to mean the content of Chlorine (Cl) and Bromine (Br) based flame retardants meet JS709B low halogen requirements of <=1000ppm threshold. Antimony trioxide based flame retardants must also meet the <=1000ppm threshold requirement.

(3) MSL, Peak Temp. - The Moisture Sensitivity Level rating according to the JEDEC industry standard classifications, and peak solder temperature.

(4) There may be additional marking, which relates to the logo, the lot trace code information, or the environmental category on the device.

(5) Multiple Device Markings will be inside parentheses. Only one Device Marking contained in parentheses and separated by a "~" will appear on a device. If a line is indented then it is a continuation of the previous line and the two combined represent the entire Device Marking for that device.

<sup>(6)</sup> Lead finish/Ball material - Orderable Devices may have multiple material finish options. Finish options are separated by a vertical ruled line. Lead finish/Ball material values may wrap to two lines if the finish value exceeds the maximum column width.

**Important Information and Disclaimer:**The information provided on this page represents TI's knowledge and belief as of the date that it is provided. TI bases its knowledge and belief on information provided by third parties, and makes no representation or warranty as to the accuracy of such information. Efforts are underway to better integrate information from third parties. TI has taken and continues to take reasonable steps to provide representative and accurate information but may not have conducted destructive testing or chemical analysis on incoming materials and chemicals. TI and TI suppliers consider certain information to be proprietary, and thus CAS numbers and other limited information may not be available for release.

In no event shall TI's liability arising out of such information exceed the total purchase price of the TI part(s) at issue in this document sold by TI to Customer on an annual basis.

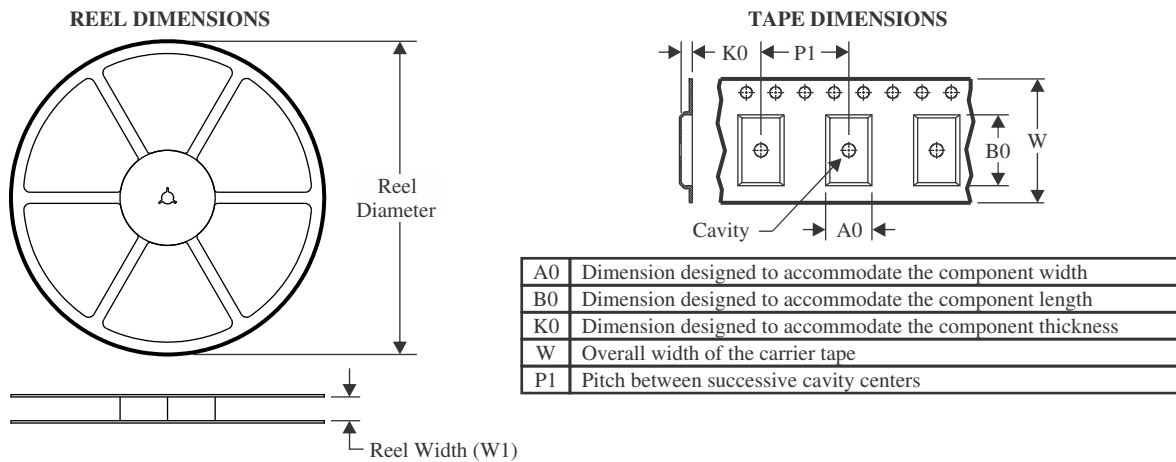
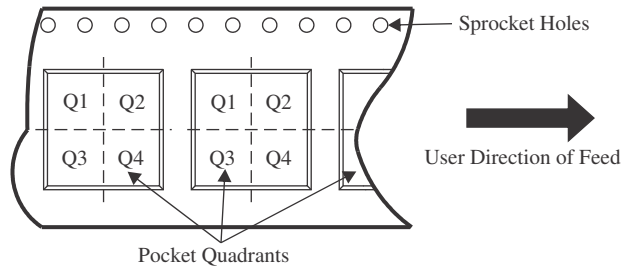
**TAPE AND REEL INFORMATION**

**QUADRANT ASSIGNMENTS FOR PIN 1 ORIENTATION IN TAPE**

\*All dimensions are nominal

Device	Package Type	Package Drawing	Pins	SPQ	Reel Diameter (mm)	Reel Width W1 (mm)	A0 (mm)	B0 (mm)	K0 (mm)	P1 (mm)	W (mm)	Pin1 Quadrant
MAX211CDBR	SSOP	DB	28	2000	330.0	16.4	8.2	10.5	2.5	12.0	16.0	Q1
MAX211CDWR	SOIC	DW	28	1000	330.0	32.4	11.35	18.67	3.1	16.0	32.0	Q1
MAX211IDBR	SSOP	DB	28	2000	330.0	16.4	8.2	10.5	2.5	12.0	16.0	Q1
MAX211IDWR	SOIC	DW	28	1000	330.0	32.4	11.35	18.67	3.1	16.0	32.0	Q1

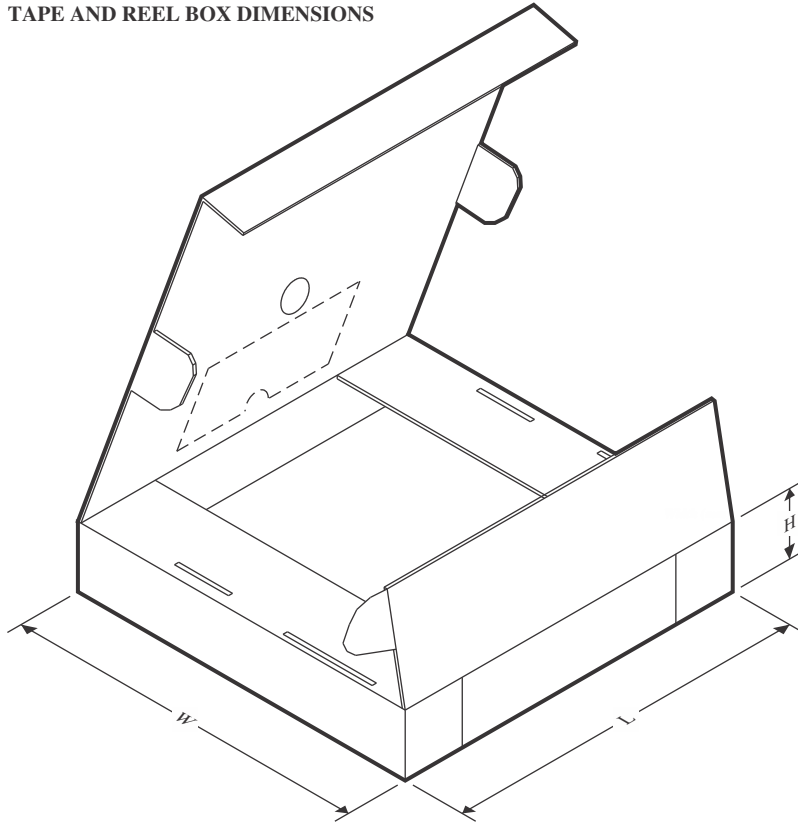
## TAPE AND REEL BOX DIMENSIONS



\*All dimensions are nominal

Device	Package Type	Package Drawing	Pins	SPQ	Length (mm)	Width (mm)	Height (mm)
MAX211CDBR	SSOP	DB	28	2000	356.0	356.0	35.0
MAX211CDWR	SOIC	DW	28	1000	350.0	350.0	66.0
MAX211IDBR	SSOP	DB	28	2000	356.0	356.0	35.0
MAX211IDWR	SOIC	DW	28	1000	350.0	350.0	66.0

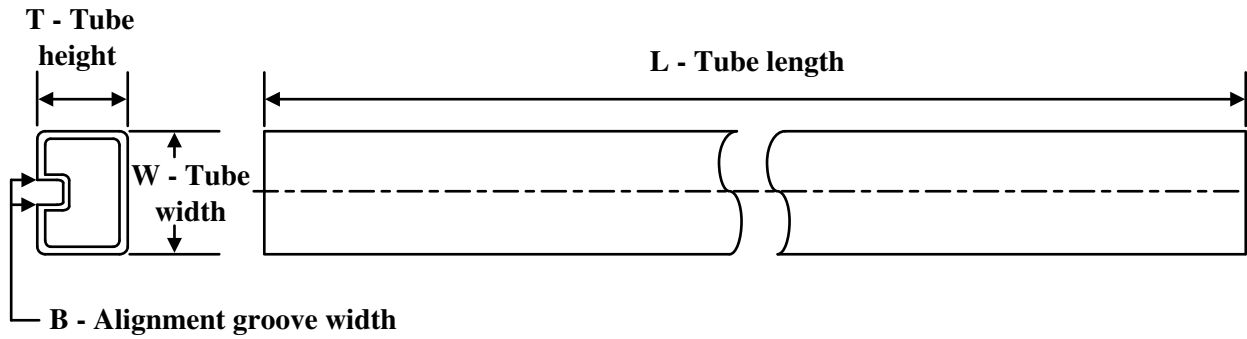

**TUBE**

\*All dimensions are nominal

Device	Package Name	Package Type	Pins	SPQ	L (mm)	W (mm)	T (μm)	B (mm)
MAX211CDB	DB	SSOP	28	50	530	10.5	4000	4.1
MAX211CDW	DW	SOIC	28	20	506.98	12.7	4826	6.6
MAX211IDB	DB	SSOP	28	50	530	10.5	4000	4.1
MAX211IDW	DW	SOIC	28	20	506.98	12.7	4826	6.6

DW (R-PDSO-G28)

PLASTIC SMALL OUTLINE

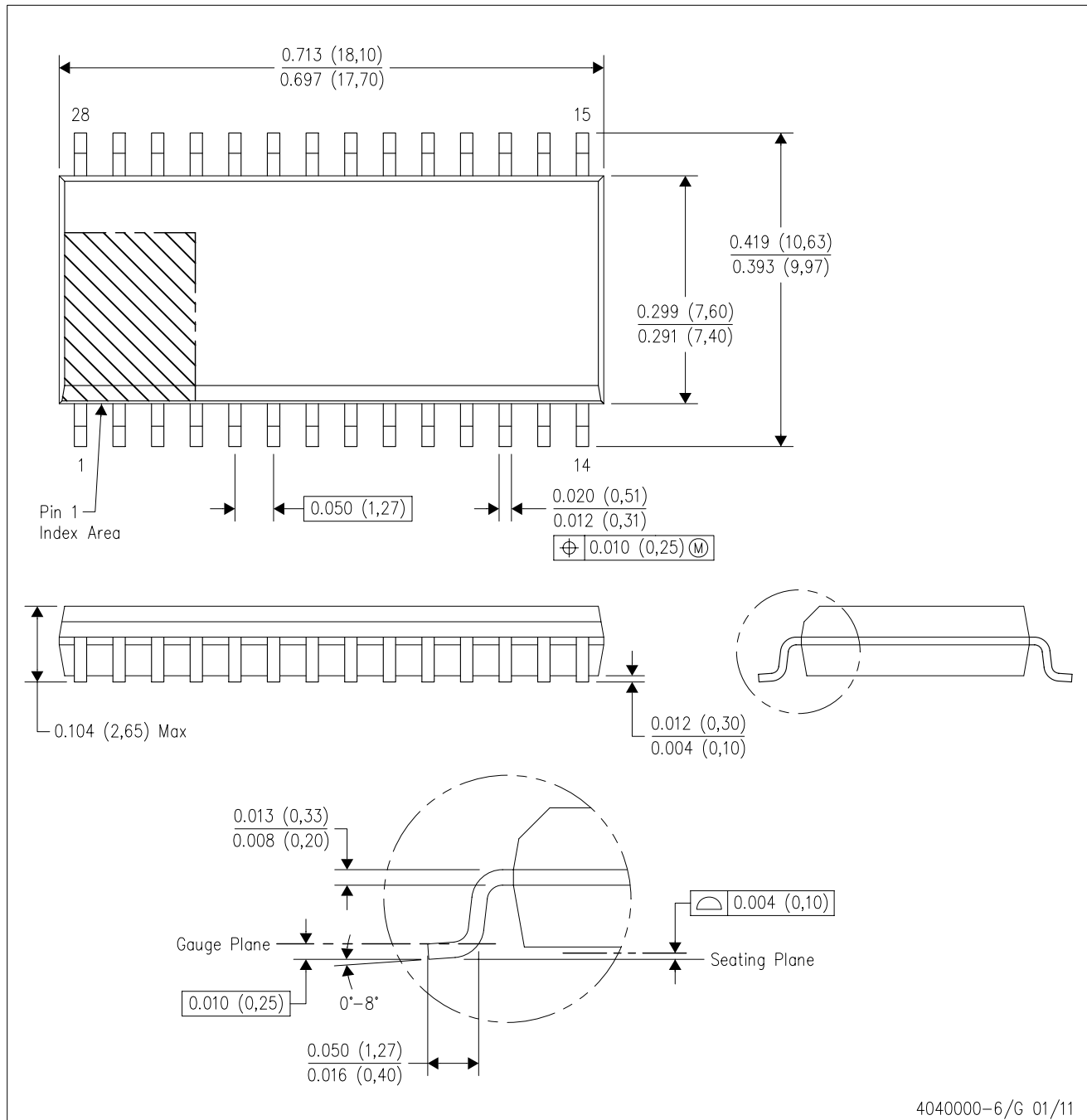

4040000-6/G 01/11

- NOTES:
- All linear dimensions are in inches (millimeters). Dimensioning and tolerancing per ASME Y14.5M-1994.
  - This drawing is subject to change without notice.
  - Body dimensions do not include mold flash or protrusion not to exceed 0.006 (0,15).
  - Falls within JEDEC MS-013 variation AE.

# DB0028A



# PACKAGE OUTLINE

## SSOP - 2 mm max height

SMALL OUTLINE PACKAGE

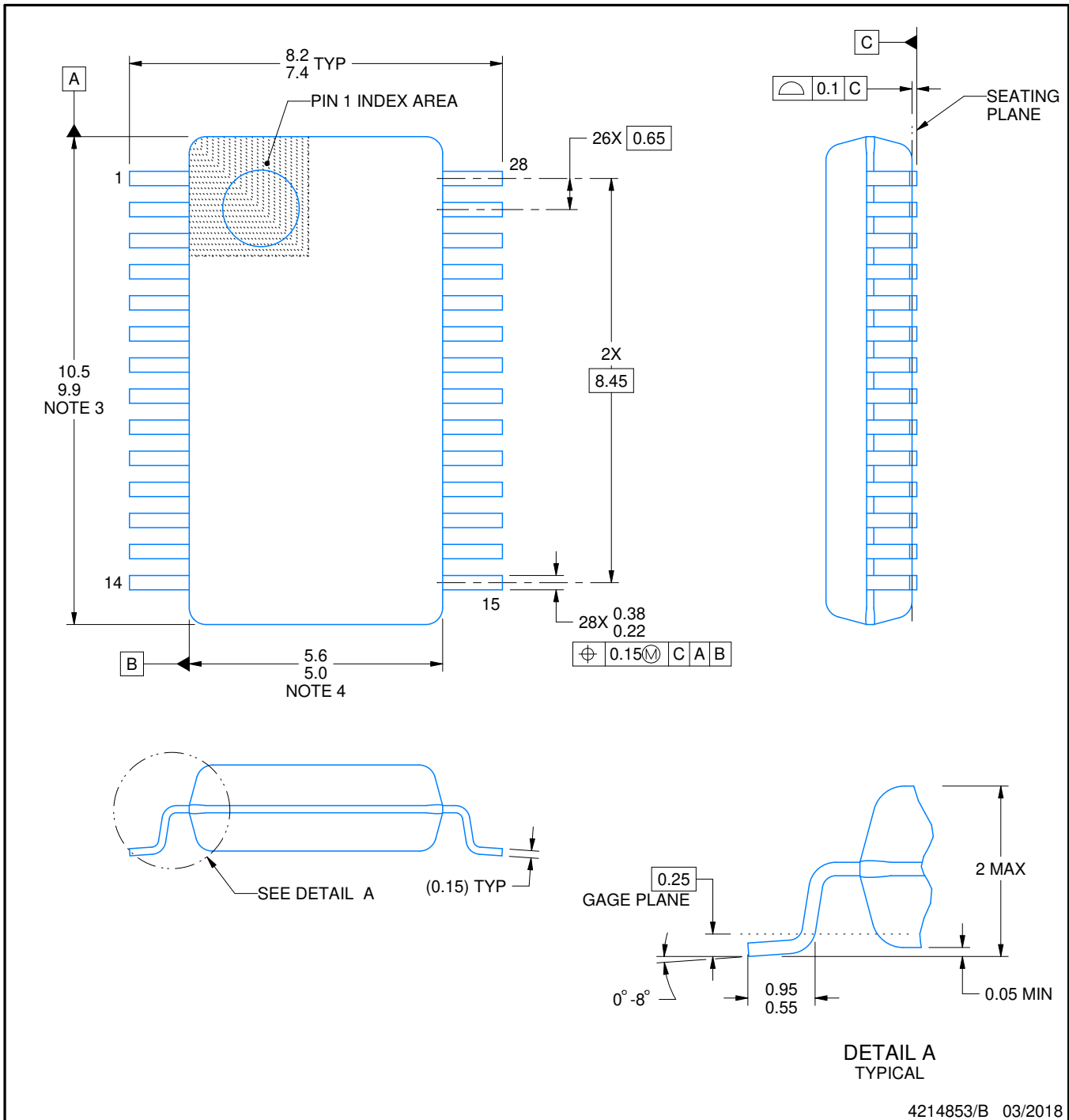

4214853/B 03/2018

### NOTES:

1. All linear dimensions are in millimeters. Any dimensions in parenthesis are for reference only. Dimensioning and tolerancing per ASME Y14.5M.
2. This drawing is subject to change without notice.
3. This dimension does not include mold flash, protrusions, or gate burrs. Mold flash, protrusions, or gate burrs shall not exceed 0.15 mm per side.
4. This dimension does not include interlead flash. Interlead flash shall not exceed 0.25 mm per side.
5. Reference JEDEC registration MO-150.

# EXAMPLE BOARD LAYOUT

DB0028A

SSOP - 2 mm max height

SMALL OUTLINE PACKAGE

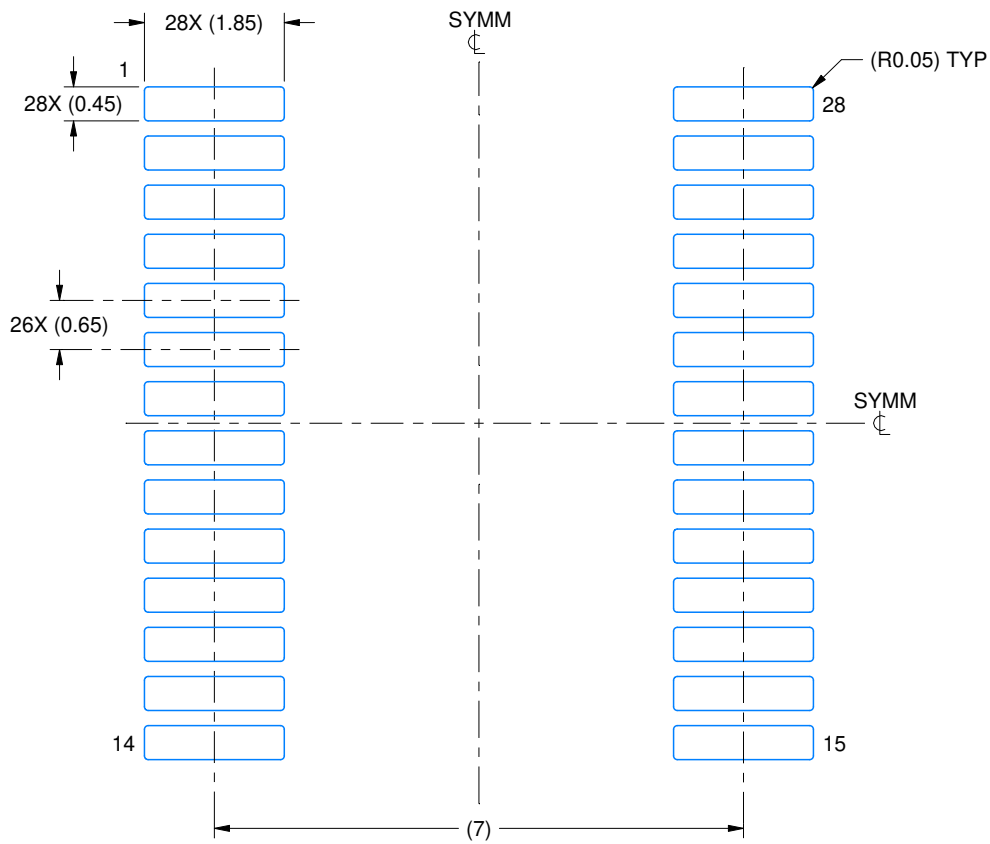

LAND PATTERN EXAMPLE  
EXPOSED METAL SHOWN  
SCALE: 10X

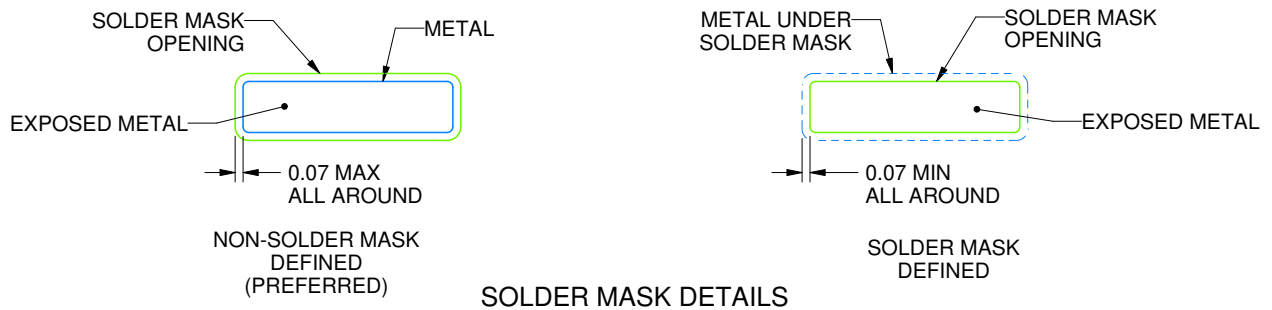

4214853/B 03/2018

NOTES: (continued)

- 6. Publication IPC-7351 may have alternate designs.
- 7. Solder mask tolerances between and around signal pads can vary based on board fabrication site.

# EXAMPLE STENCIL DESIGN

DB0028A

SSOP - 2 mm max height

SMALL OUTLINE PACKAGE

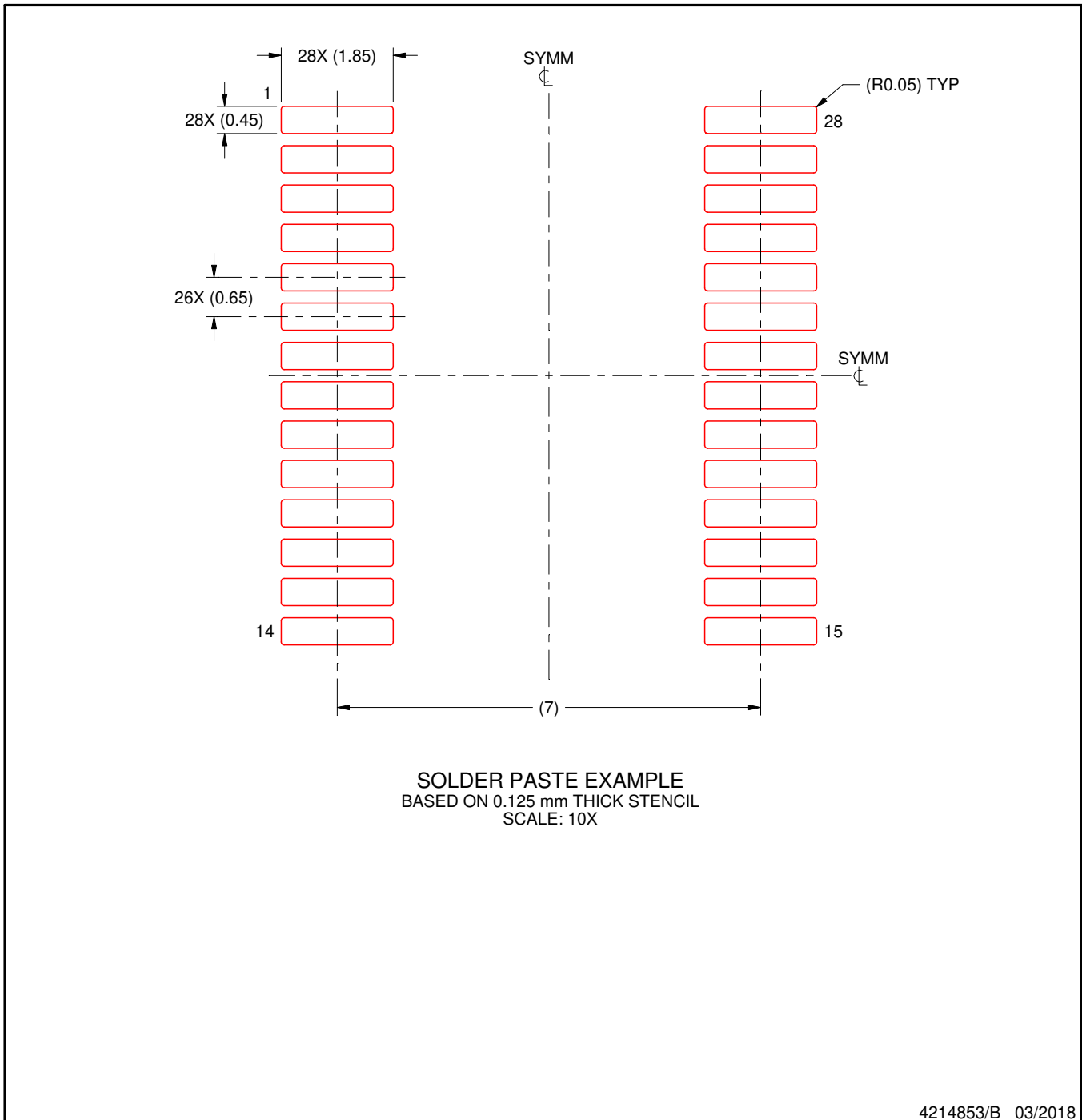

NOTES: (continued)

8. Laser cutting apertures with trapezoidal walls and rounded corners may offer better paste release. IPC-7525 may have alternate design recommendations.
9. Board assembly site may have different recommendations for stencil design.

## IMPORTANT NOTICE AND DISCLAIMER

TI PROVIDES TECHNICAL AND RELIABILITY DATA (INCLUDING DATA SHEETS), DESIGN RESOURCES (INCLUDING REFERENCE DESIGNS), APPLICATION OR OTHER DESIGN ADVICE, WEB TOOLS, SAFETY INFORMATION, AND OTHER RESOURCES "AS IS" AND WITH ALL FAULTS, AND DISCLAIMS ALL WARRANTIES, EXPRESS AND IMPLIED, INCLUDING WITHOUT LIMITATION ANY IMPLIED WARRANTIES OF MERCHANTABILITY, FITNESS FOR A PARTICULAR PURPOSE OR NON-INFRINGEMENT OF THIRD PARTY INTELLECTUAL PROPERTY RIGHTS.

These resources are intended for skilled developers designing with TI products. You are solely responsible for (1) selecting the appropriate TI products for your application, (2) designing, validating and testing your application, and (3) ensuring your application meets applicable standards, and any other safety, security, regulatory or other requirements.

These resources are subject to change without notice. TI grants you permission to use these resources only for development of an application that uses the TI products described in the resource. Other reproduction and display of these resources is prohibited. No license is granted to any other TI intellectual property right or to any third party intellectual property right. TI disclaims responsibility for, and you will fully indemnify TI and its representatives against, any claims, damages, costs, losses, and liabilities arising out of your use of these resources.

TI's products are provided subject to [TI's Terms of Sale](#) or other applicable terms available either on [ti.com](https://www.ti.com) or provided in conjunction with such TI products. TI's provision of these resources does not expand or otherwise alter TI's applicable warranties or warranty disclaimers for TI products.

TI objects to and rejects any additional or different terms you may have proposed.

Mailing Address: Texas Instruments, Post Office Box 655303, Dallas, Texas 75265  
Copyright © 2023, Texas Instruments Incorporated