

PART NUMBER	SML-LXT0805YW-TR	REV	H
REV	E.C.N. NUMBER AND REVISION COMMENTS	DATE	
A	E.C.N #10567.	12.08.99	
B	E.C.N #10695.	01.08.01	
C	E.C.N #10814.	02.25.02	
D	E.C.N #10967.	03.22.04	
E	E.C.N #11248.	08.12.05	
F	E.C.N #11508.	09.30.09	
G	ECN-Lumex201800039	03.06.18	
H	ECN-Lumex201900133	12.17.19	

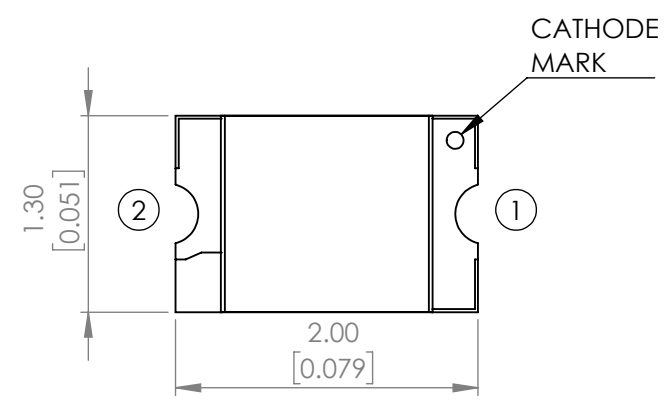

POLARITY

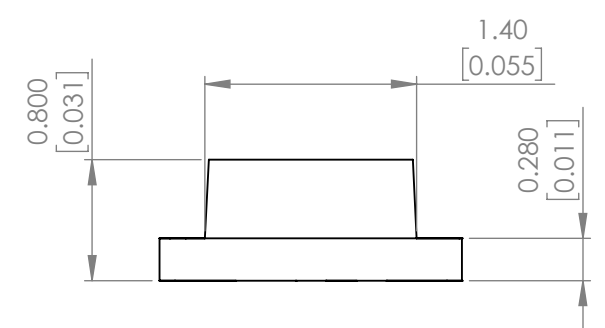
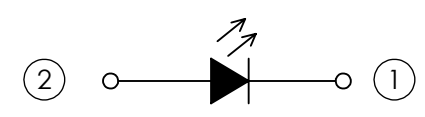

RECOMMENDED SOLDER PAD LAYOUT

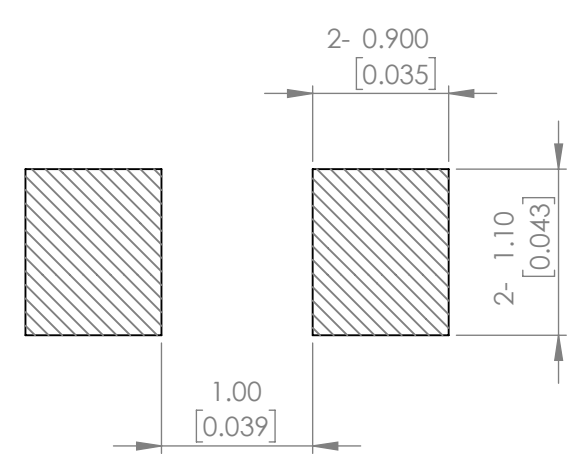
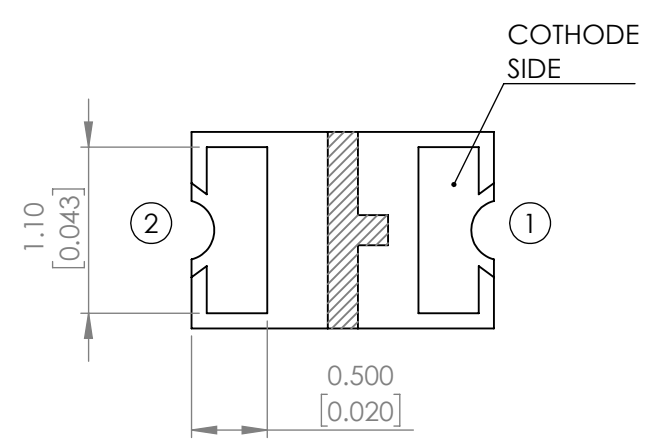

ELECTRO-OPTICAL CHARACTERISTIC TA=25°C

PARAMETER	MIN	TYP	MAX	UNITS	TEST COND
PEAK WAVELENGTH	-	585	-	nm	If=20mA
FORWARD VOLTAGE	-	2.1	2.6	Vf	If=20mA
REVERSE CURRENT	-	-	10	uA	Vr=5V
LUMINOUS INTENSITY	-	7	-	mcd	If=20mA
VIEWING ANGLE	-	130	-	2x theta1/2	-
EMITTED COLOR	YELLOW				
EPOXY LENS FINISH	MILKY WHITE DIFFUSED				

ABSOLUTE MAXIMUM RATINGS TA=25°C

PARAMETER	MAX	UNITS
PEAK FORWARD CURRENT*	40	mA
FORWARD CURRENT	20	mA
REVERSE VOLTAGE	5	V
POWER DISSIPATION	52	mW
STORAGE TEMPERATURE	-40 TO +100	°C
OPERATING TEMPERATURE	-40 TO +85	°C

*t<10us
**2.0mm FROM BODY.

MOISTURE SENSITIVE DEVICE
PER JEDEC LEVEL 2a STANDARDS

*UNLESS OTHERWISE SPECIFIED TOLERANCES PER DECIMAL PRECISION ARE: X=±1 (±0.039), X.X=±0.5 (±0.020), X.XX=±0.25 (±0.010), X.XXX=±0.127 (±0.005). LEAD SIZE=±0.05 (±0.002), LEAD LENGTH=±0.75 (±0.030). MIN= ^{+DECIMAL PRECISION}/_{-0.00} MAX= ^{+0.00}/_{-DECIMAL PRECISION}

PROFILE

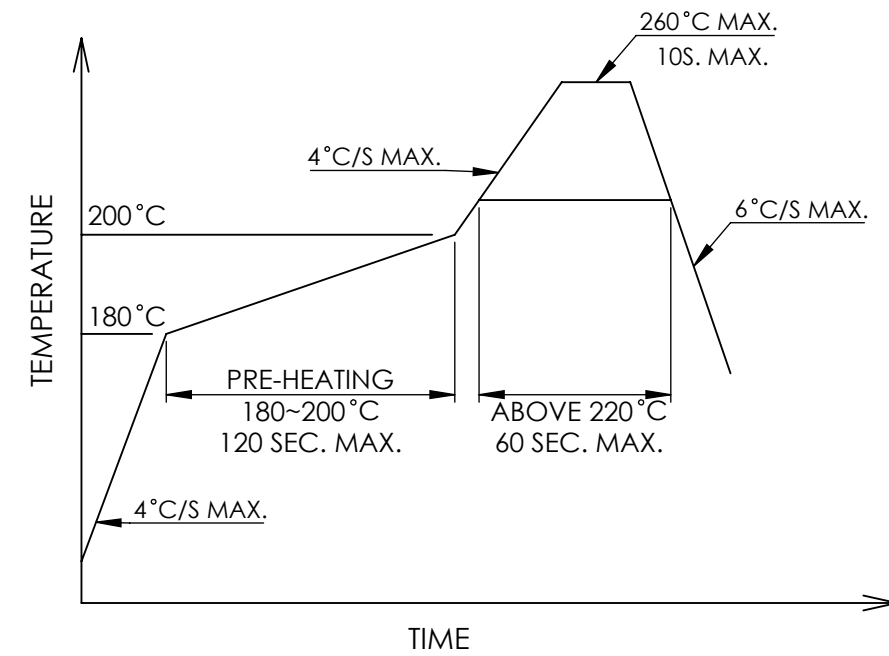

CARRIER TAPE DIMENSION

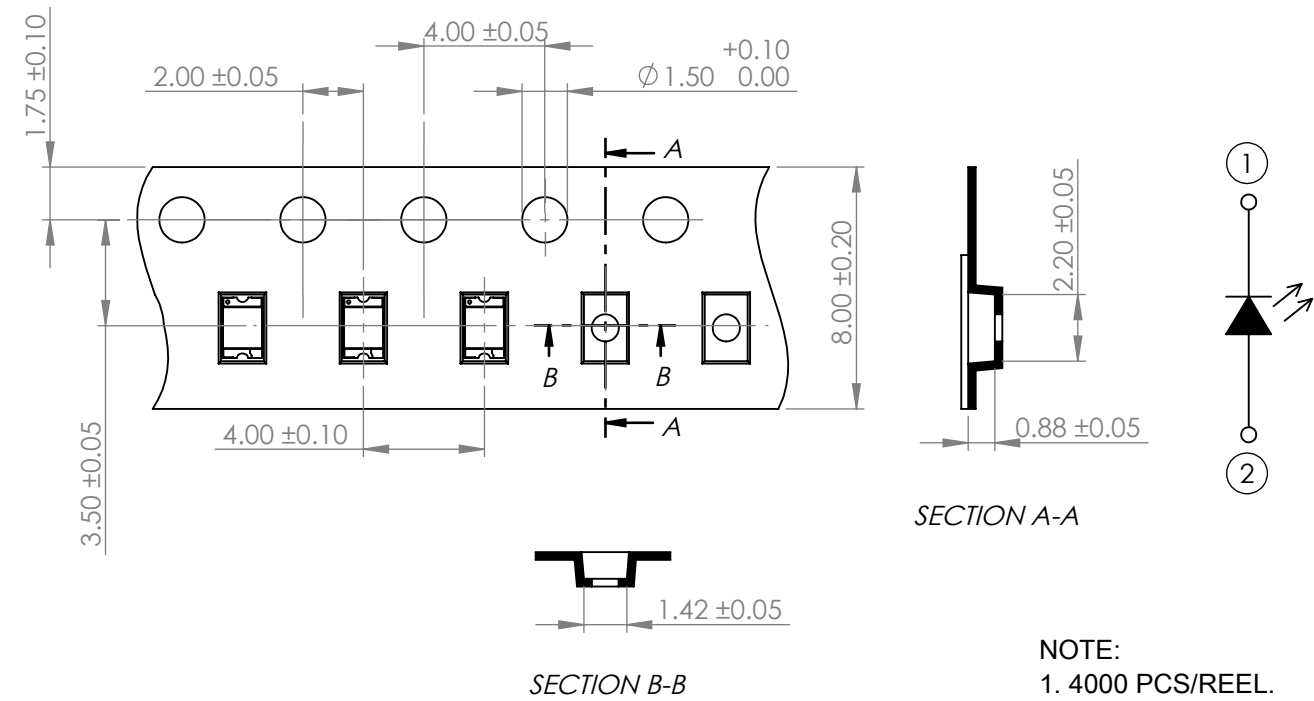

*UNLESS OTHERWISE SPECIFIED TOLERANCES PER DECIMAL PRECISION ARE: X=±1 (±0.039), X.X=±0.5 (±0.020), X.XX=±0.25 (±0.010), X.XXX=±0.127 (±0.005). LEAD SIZE=±0.05 (±0.002), LEAD LENGTH=±0.75 (±0.030). MIN= ^{+DECIMAL PRECISION} / _{-0.00} MAX. = ^{+0.00} / _{-DECIMAL PRECISION}



425 N. GARY AVE.
CAROL STREAM, IL 60188
PHONE : 800-278-5666
FAX : 630-315-2150
WEB : WWW.LUMEX.COM

2.00(L)*1.30(W)*0.80(H, THIN PCB SURFACE MOUNT LED, 585nm GaAsP YELLOW, MILKY WHITE DIFFUSED, TAPE & REEL.
****THE SPECIFICATIONS MAY CHANGE AT ANY TIME WITHOUT NOTICE.****
CONFIDENTIAL INFORMATION
THE INFORMATION CONTAINED IN THIS DOCUMENT IS THE PROPERTY OF LUMEX INC. EXCEPT AS SPECIFICALLY AUTHORIZED IN WRITING BY LUMEX INC., THE HOLDER OF THIS DOCUMENT SHALL KEEP ALL INFORMATION CONTAINED HEREIN CONFIDENTIAL AND SHALL PROTECT SAME IN WHOLE OR IN PART FROM DISCLOSURE AND DISSEMINATION TO ALL THIRD PARTIES.

DATE : 2019.12.17	DRAWN BY : C.S.
PAGE : 2 OF 2	CHKD BY : E.C.
SCALE : NTF	APRVD BY : G.Y.
UNIT : mm [INCH]	(Pb)