

THIS DRAWING IS UNPUBLISHED. RELEASED FOR PUBLICATION
 BY AMP INCORPORATED. ALL RIGHTS RESERVED.

Loc		DIST		REVISIONS			
P	LTR	DESCRIPTION		DATE	DWN	APVD	
FT	8	U		REDRAWN W/O CHANGE PER EC 0320-98-96	20 NOV 97	-	-

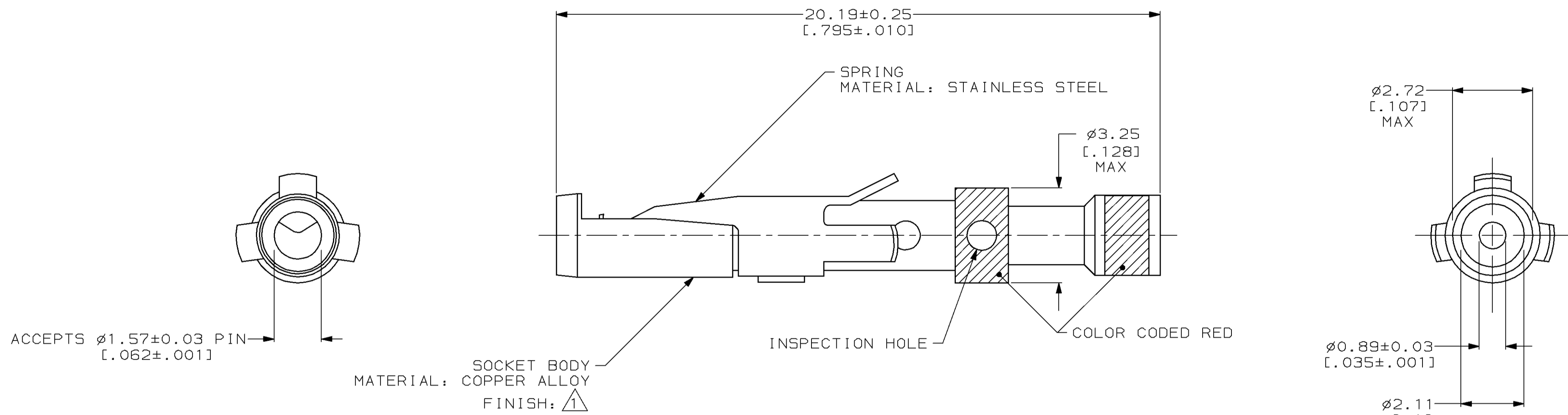

ACCEPTS $\phi 1.57 \pm 0.03$ PIN
 $[.062 \pm .001]$

SOCKET BODY
 MATERIAL: COPPER ALLOY
 FINISH: $\Delta 1$

INSPECTION HOLE

COLOR CODED RED

$\Delta 1$ 0.76µm [0.00030] MIN GOLD OVER 1.27µm [0.00050] MIN NICKEL.

201332-1
 PART NUMBER

THIS DRAWING IS A CONTROLLED DOCUMENT.		DWN B. CARBO	20 NOV 97	AMP AMP Incorporated Harrisburg, PA 17105-3608
DIMENSIONS: mm [INCHES]		CHK R. STONE	09 DEC 97	
TOLERANCES UNLESS OTHERWISE SPECIFIED:		APVD G. STEINHAUER	16 DEC 97	CONTACT ASSEMBLY, SOCKET, #16, 24-28AWG, TYPE II
0 PLC ±-		PRODUCT SPEC	-	
1 PLC ±-		APPLICATION SPEC	-	SIZE
2 PLC ±0.13 [0.005]		WEIGHT	-	CAGE CODE
3 PLC ±-		CUSTOMER DRAWING	A2	00779
4 PLC ±-		SCALE	10:1	DRAWING NO
ANGLES ±-		SHEET	1 OF 1	201332
FINISH		REV	U	RESTRICTED TO
SEE CALLOUTS				

201332