

USB 2.0 High-Speed (480 Mbps) Switch with 5V Protection with Improved Ioff Voltage Range

Features

- USB 2.0 compliant (high speed, full speed, and low speed)
- R_{ON} : 4.0Ω typical @ $V_{DD} = 3.0V$
- Channel On Capacitance: 6.0pF
- Wide -3dB Bandwidth: 1,000MHz
- Low bit-to-bit skew
- Low Crosstalk: -29dB @ 480 Mbps
- Off Isolation: -28dB @ 480 Mbps
- Near-Zero propagation delay: 250ps
- Support 1.8-V logic on control pins
- V_{DD} Operating Range: 3.0V to 5.5V
- ESD: 8kV HBM on Y+/Y- pins per JESD22 standard
- Y+/Y- pins have over-voltage protection and can tolerate a short to VBUS
- Totally Lead-Free & Fully RoHS Compliant (Notes 1 & 2)
- Halogen and Antimony Free. “Green” Device (Note 3)
- Packaging (Pb-free & Green):
 - 10-contact TQFN, 1.3mm x 1.6mm x 0.75mm (ZL10)

Description

The PI3USB102G is a single differential channel 2:1 multiplexer/demultiplexer USB 2.0 Switch. Industry leading advantages include a propagation delay of 250ps, resulting from its low channel resistance and I/O capacitance. PI3USB102G is bidirectional and offers very little attenuation of high-speed signals. It is designed for low bit-to-bit skew, high channel-to-channel noise isolation and is compatible with various standards, such as High Speed USB 2.0 (480 Mb/s).

The PI3USB102G offers over voltage protection for the Y+/Y- pins as per the USB 2.0 specification. With the chip powered on or off if Y+/Y- pins are shorted to VBUS (5V +/- 5%), M+/M- and D+/D- outputs are clamped to provide voltage protection for downstream devices.

The PI3USB102G has a better Y+/Y- power-off leakage current with the voltage range of 0V to 5V versus 0V to 3.3V for the PI3USB102E.

Application

- Routes signals for USB 2.0
- PC, Notebooks and Hand-held devices

Block Diagram

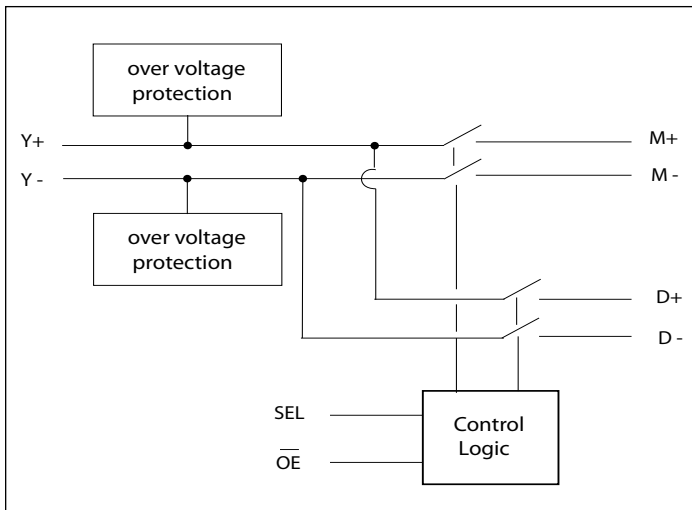

Notes:

1. No purposely added lead. Fully EU Directive 2002/95/EC (RoHS), 2011/65/EU (RoHS 2) & 2015/863/EU (RoHS 3) compliant.
2. See <https://www.diodes.com/quality/lead-free/> for more information about Diodes Incorporated’s definitions of Halogen- and Antimony-free, “Green” and Lead-free.
3. Halogen- and Antimony-free “Green” products are defined as those which contain <900ppm bromine, <900ppm chlorine (<1500ppm total Br + Cl) and <1000ppm antimony compounds.

Truth Table

SEL	$\overline{\text{OE}}$	Y+	Y-
X	H	Hi-Z	Hi-Z
L	L	M+	M-
H	L	D+	D-

Pin Configuration

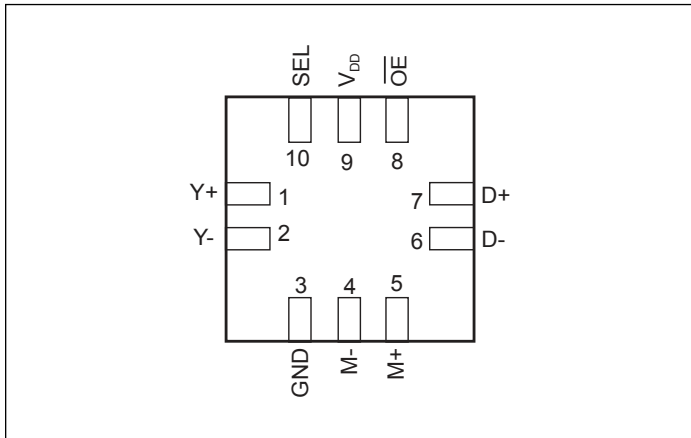

Pin Description

Pin#	Pin Name	Description
1	Y+	USB Data bus
2	Y-	USB Data bus
3	GND	Ground
4	M-	Multiplexed Source Inputs
5	M+	Multiplexed Source Inputs
6	D-	Multiplexed Source Inputs
7	D+	Multiplexed Source Inputs
8	OE	Switch Enable
9	$\overline{\text{V}}_{\text{DD}}$	Positive Power Supply
10	SEL	Switch Select

Maximum Ratings

(Above which useful life may be impaired. For user guidelines, not tested.)

Storage Temperature	-65°C to +150°C
Junction Temperature	125°C
Supply Voltage to Ground Potential	-0.5V to +6V
DC Input Voltage	-0.5V to +6V
DC Output Current	120mA
Power Dissipation	0.5W

Note: Stresses greater than those listed under MAXIMUM RATINGS may cause permanent damage to the device. This is a stress rating only and functional operation of the device at these or any other conditions above those indicated in the operational sections of this specification is not implied. Exposure to absolute maximum rating conditions for extended periods may affect reliability.

DC Electrical Characteristics for USB 2.0 Switching over Operating Range

($T_A = -40^\circ\text{C}$ to $+85^\circ\text{C}$, $V_{DD} = 3.0 - 5.5\text{V}$)

Parameter	Description	Test Conditions ⁽¹⁾	Min.	Typ. ⁽²⁾	Max.	Units
V_{IH}	Input HIGH Voltage	Guaranteed HIGH level	1.4			V
V_{IL}	Input LOW Voltage	Guaranteed LOW level			0.8	
V_{IK}	Clamp Diode Voltage	$V_{DD} = \text{Max.}, I_{IK} = -18\text{mA}$		-0.7	-1.2	
I_{IH}	Input HIGH Current for SEL and \overline{OE}	$V_{DD} = \text{Max.}, V_{IH} = V_{DD}$	-100		100	nA
I_{IL}	Input LOW Current for SEL and \overline{OE}	$V_{DD} = \text{Max.}, V_{IL} = \text{GND}$	-100		100	
I_{IH}	Input HIGH Current for Y+/Y-	$V_{DD} = 3.3\text{V}, V_Y = 5.25\text{V}$			50	uA
I_{IL}	Input LOW Current for Y+/Y-	$V_{DD} = 3.3\text{V}, V_Y = 0\text{V}$			1	
I_{Leakage}	Leakage from Y+/Y- to Vdd when $V_{Y+/Y-} > V_{DD}$	$V_{DD} = 3.3\text{V}, V_{Y+/Y-} = 5.25\text{V}, \overline{OE} = \text{LOW}$			200	nA
R_{ON}	Switch On-Resistance ⁽³⁾	$V_{DD} = 3\text{V}, 0\text{V} \leq V_{\text{input}} \leq 1.0\text{V}, I_{ON} = -40\text{mA}$		4.0	5.0	Ω
$R_{\text{FLAT(ON)}}$	On-Resistance Flatness ⁽³⁾	$V_{DD} = 3\text{V}, 0\text{V} \leq V_{\text{input}} \leq 1.0\text{V}, I_{ON} = -40\text{mA}$		1.5		
ΔR_{ON}	On-Resistance match from center ports to any other port ⁽³⁾	$V_{DD} = 3\text{V}, 0\text{V} \leq V_{\text{input}} \leq 1.0\text{V}, I_{ON} = -40\text{mA}$		0.9	2.0	
V_{OVP}	Input Over-Voltage Protection Threshold ⁽⁴⁾	$V_{DD} = 3.0\text{V}$	3.1	3.2	3.4	V
		$V_{DD} = 3.3\text{V}$	3.4	3.5	3.7	
		$V_{DD} = 3.6\text{V}$	3.7	3.8	4.0	
I_{OZ_M}	Output leakage current on port M when D path is on	$V_{Y+/Y-} = 5.25\text{V}, V_{DD} = 3.3\text{V}$ SEL = High, $V_{M+/M-} = 0\text{V}$	-200		200	nA
I_{OZ_D}	Output leakage current on port D when M path is on	$V_{Y+/Y-} = 5.25\text{V}, V_{DD} = 3.3\text{V}$ SEL = Low, $V_{D+/D-} = 0\text{V}$	-200		200	nA
I_{OFF}	Y+/Y- Power-Off Leakage Current	$V_{\text{input}} = 0\text{V to } 5\text{V}, V_{DD} = 0\text{V}$		0.2	1	uA

Power Supply Characteristics

Parameters	Description	Test Conditions ⁽¹⁾	Min.	Typ.	Max.	Units
I_{DD}	Power Supply Current	$V_{DD} = 3.3\text{V}, \overline{OE} = \text{GND}, V_{\text{SEL}} = \text{GND or } V_{DD}$		1	2	uA

Notes:

- For max. or min. conditions, use appropriate value specified under Electrical Characteristics for the applicable device type.
- $V_{DD} = 3.0 - 5.5\text{V}, T_A = 25^\circ\text{C}$ ambient.
- Measured by the voltage drop between Y+/Y- and the lower of M+/M- and D+/D- at indicated current through the Switch.
- When the voltage at Y+/Y- is greater than $V_{DD} + 0.2\text{V}$, over-voltage protection limits the output voltage at M+/- and D+/- to protect connected devices from damage.

Capacitance ($T_A = 25^\circ\text{C}$, $V_{DD} = 3.3\text{V}$, $f = 1\text{MHz}$)

Parameters ⁽³⁾	Description	Test Conditions ⁽¹⁾	Typ. ⁽²⁾	Max.	Units
C_{IN}	Input Capacitance		2.2	3.2	pF
$C_{OFF (M/D)}$	Switch Off Capacitance for M and D ports	$\overline{OE} = \text{High}$	3.0	4.0	
$C_{OFF (Y)}$	Switch Off Capacitance for Y port	$\overline{OE} = \text{High}$	5.0	6.0	
C_{ON}	Switch Capacitance, Switch ON	$V_{SEL} = 0\text{V}$ or V_{DD}	6.0	7.0	

Dynamic Electrical Characteristics Over the Operating Range

Parameters ⁽³⁾	Description	Test Conditions	Min.	Typ. ⁽²⁾	Max.	Units
X_{TALK}	Crosstalk	$R_L = 50\Omega$, $f = 240\text{MHz}$		-29		dB
O_{IRR}	OFF Isolation			-28		
-3dB BW	-3dB Bandwidth	$R_L = 50\Omega$		1,000		MHz
-0.5dB BW	-0.5dB Bandwidth	$R_L = 50\Omega$		275		MHz
T_{OVP}	Over-Voltage Response Time ⁽⁴⁾	$C_L = 10\text{pF}$, $V_{Y+/Y-} = 5\text{V}$, $V_{DD} = 3.0\text{ to }3.6\text{V}$ ⁽⁶⁾		40	100	ns
V_{DSW}	Dynamic Signal Output Swing ⁽⁵⁾	$C_L = 10\text{pF}$, $V_{Y+/Y-} = 5\text{V}$, $V_{DD} = 3.0\text{ to }3.6\text{V}$ ⁽⁶⁾	2.7	3.0	3.6	V

Notes:

- For max. or min. conditions, use appropriate value specified under Electrical Characteristics for the applicable device type.
- Typical values are at $V_{DD} = 3.3\text{V}$, $T_A = 25^\circ\text{C}$ ambient.
- This parameter is determined by device characterization but is not production tested.
- Time duration for output voltage higher than V_{OVP} when input is connected to 5V.
- Output voltage observed at M+/M- and D+/D- during over-voltage condition.
- Tested using a 750 kHz square wave with $t_r = 75\text{ns}$ and $t_f = 75\text{ns}$.

Switching Characteristics

Parameters	Description	Test Conditions ⁽¹⁾	Min.	Typ.	Max.	Units	
t_{PD}	Propagation Delay ^(2,3)	See Test Circuit for Electrical Characteristics		0.25		ns	
t_{PZH} , t_{PZL}	Line Enable Time - SEL, \overline{OE} to D(+/-), M(+/-)		0.5		50		
t_{PHZ} , t_{PLZ}	Line Disable Time - SEL, \overline{OE} to D(+/-), M(+/-)		0.5		11.0		
t_{BBM}	Break Before Make Delay			9.0			ns
t_{SKb-b}	Output skew, bit-to-bit (opposite transition of the same output ($t_{PHL}-t_{PLH}$) ⁽²⁾)				8		20

Notes:

- For max. or min. conditions, use appropriate value specified under Electrical Characteristics for the applicable device type.
- Guaranteed by design.
- The switch contributes no propagation delay other than the RC delay of the On-Resistance of the switch and the load capacitance. The time constant for the switch alone is of the order of 0.25ns for 10pF load. Since this time constant is much smaller than the rise/fall times of typical driving signals, it adds very little propagation delay to the system. Propagation delay of the switch when used in a system is determined by the driving circuit on the driving side of the switch and its interactions with the load on the driven side.

Test Circuit for Dynamic Electrical Characteristics

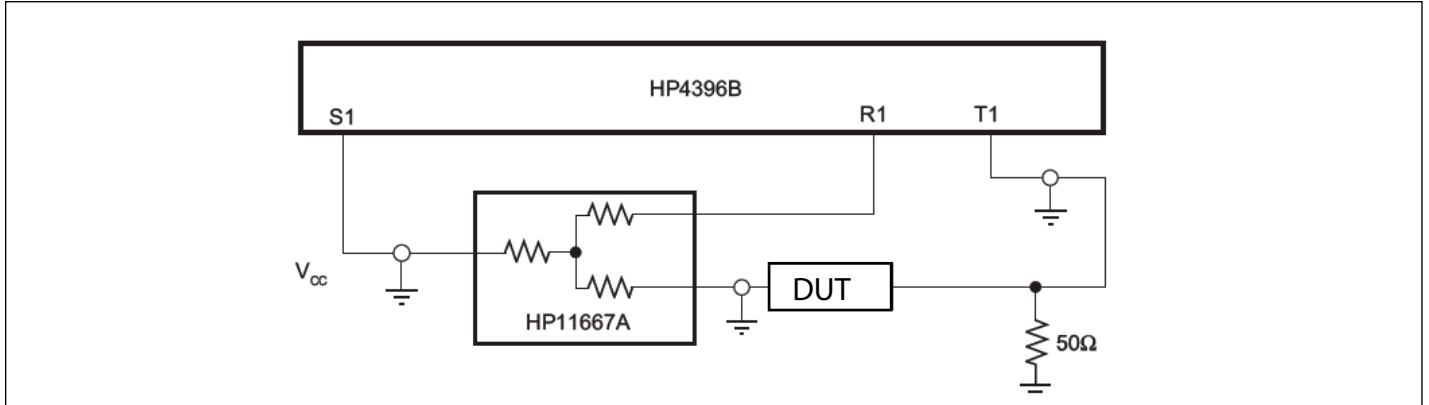

Test Circuit for Electrical Characteristics

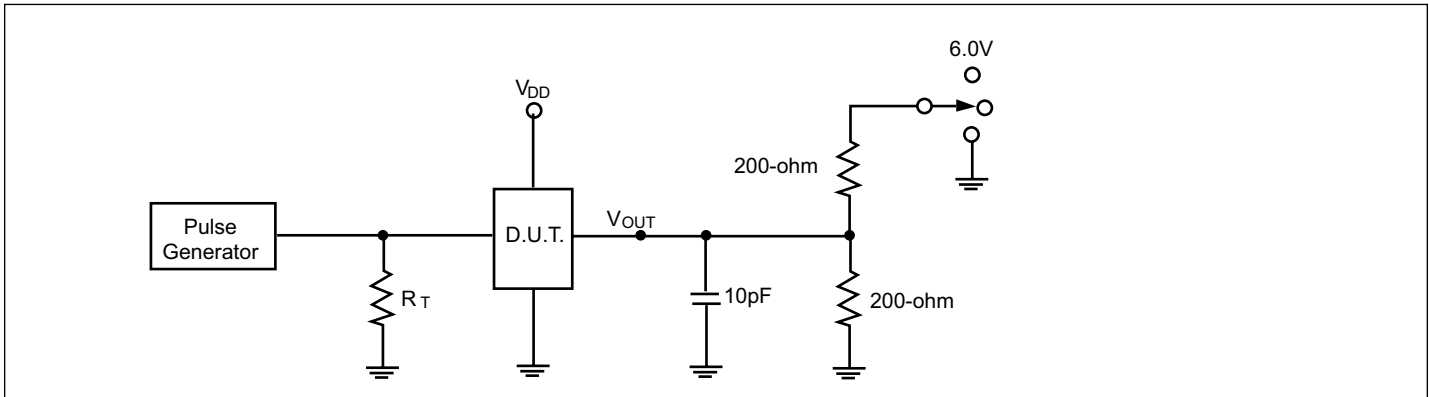

Notes:

1. C_L = Load capacitance: includes jig and probe capacitance.
2. R_T = Termination resistance: should be equal to Z_{OUT} of the Pulse Generator
3. All input impulses are supplied by generators having the following characteristics: $Z_O = 50\Omega$, $t_R \leq 2.5ns$, $t_F \leq 2.5ns$.
4. The outputs are measured one at a time with on transition per measurement.

Switch Positions

Test	Switch
t_{PLZ} , t_{PZL}	6.0V
t_{PHZ} , t_{PZH}	GND
Prop Delay	Open

Application Example Diagram

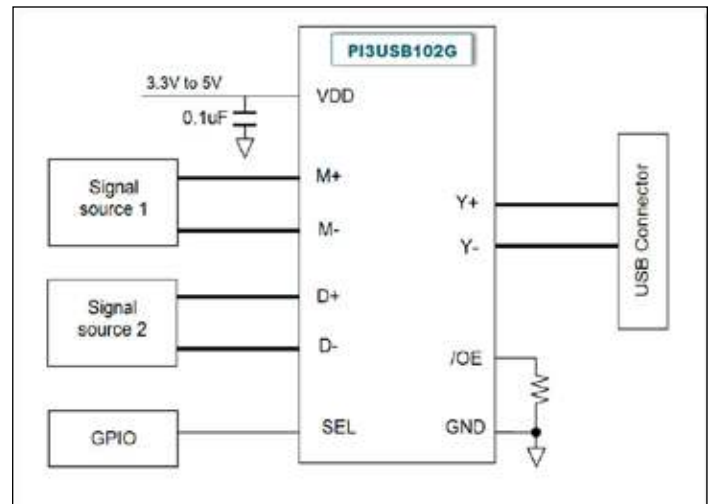

Switching Waveforms

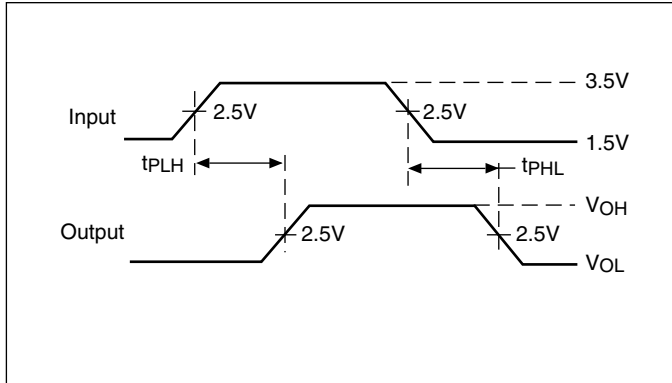

Voltage Waveforms Propagation Delay Times

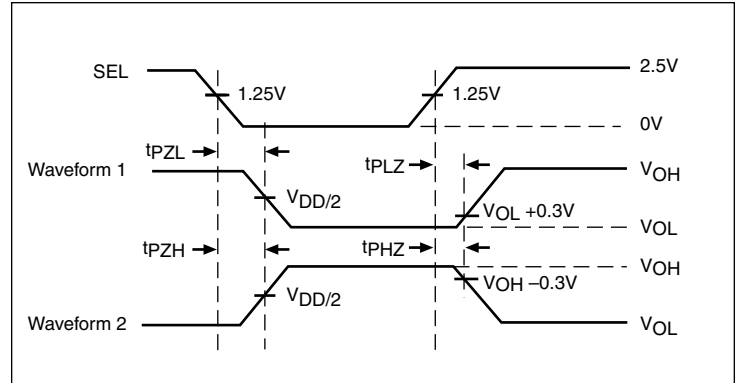

Voltage Waveforms Enable and Disable Times

Overvoltage Protection Waveforms

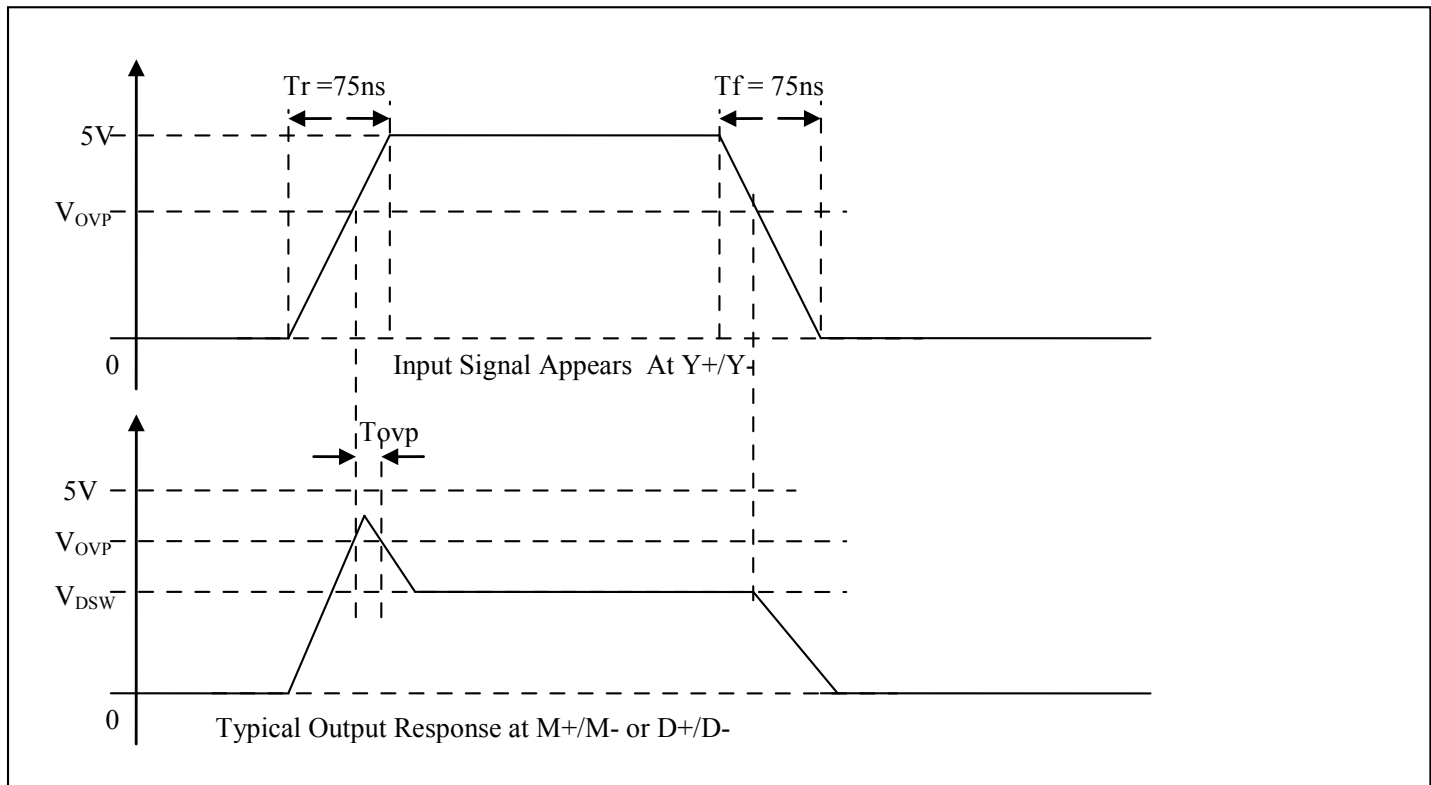

The PI3USB102G offers over voltage protection for the Y+/Y- pins to protect from shorts to VBUS (5V). When the voltage on Y+/Y- exceeds V_{OVP} , the voltage at M+/M- and D+/D- is clamped to V_{DSW} within the time T_{OVP} . For rise time of 75 ns (as per USB1.1 and USB2.0 low-speed specifications), T_{OVP} is typically 40 ns. T_{OVP} is smaller for faster risetimes. For example, T_{OVP} is typically 20 ns for rise time of 5 ns.

Part Marking

Top mark not available at this time. To obtain advance information regarding the top mark, please contact your local sales representative.

Packaging Mechanicals

10-TQFN (ZL)

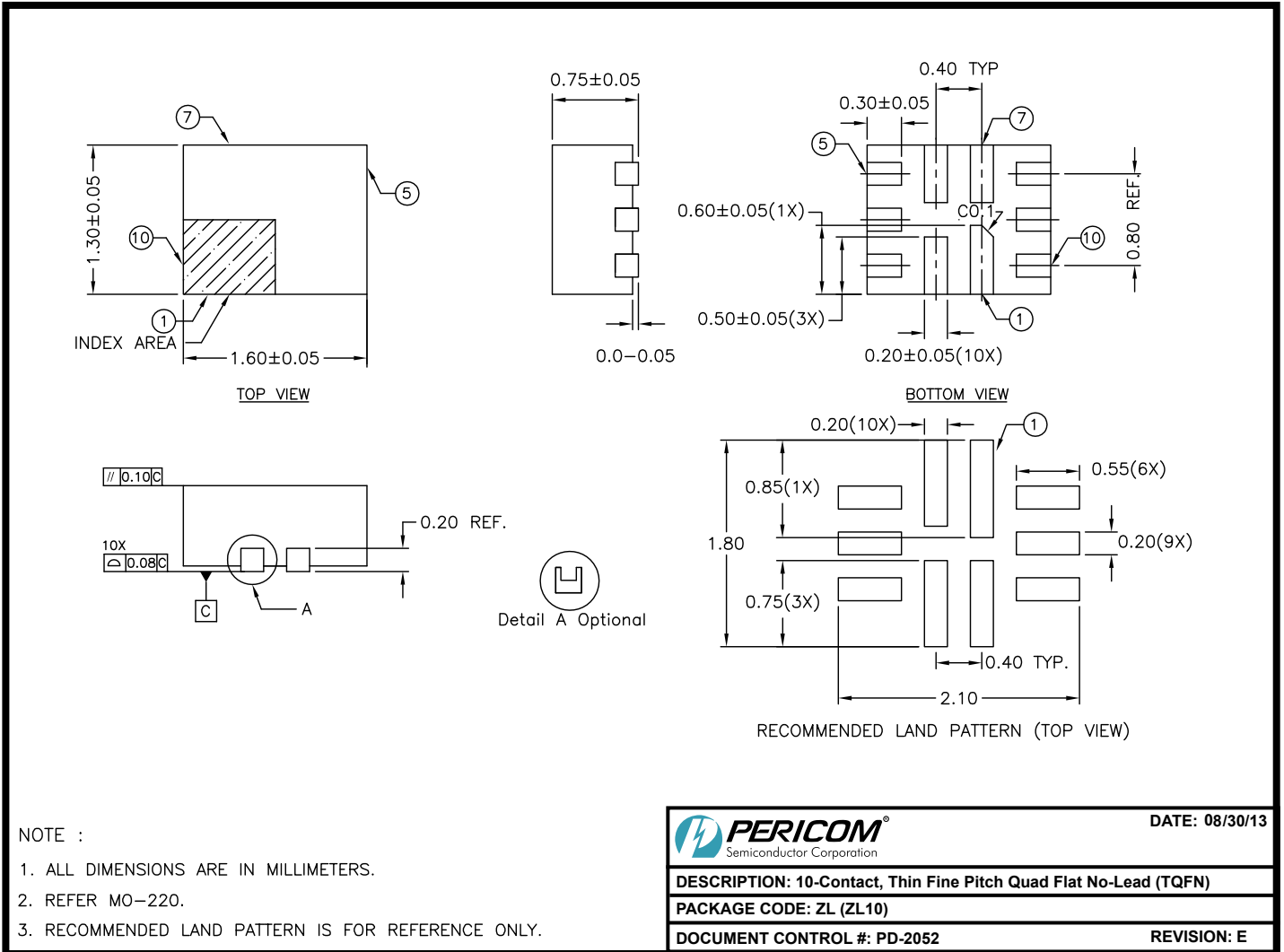

13-0175

For latest package info.

please check: <http://www.diodes.com/design/support/packaging/pericom-packaging/packaging-mechanicals-and-thermal-characteristics/>

Ordering Information

Ordering Code	Package Code	Package Description	Top Mark
PI3USB102GZLEX	ZL	10-contact, Thin Fine Pitch Quad Flat No-Lead (TQFN)	JW

Notes:

1. No purposely added lead. Fully EU Directive 2002/95/EC (RoHS), 2011/65/EU (RoHS 2) & 2015/863/EU (RoHS 3) compliant.
2. See <https://www.diodes.com/quality/lead-free/> for more information about Diodes Incorporated's definitions of Halogen- and Antimony-free, "Green" and Lead-free.
3. Halogen- and Antimony-free "Green" products are defined as those which contain <900ppm bromine, <900ppm chlorine (<1500ppm total Br + Cl) and <1000ppm antimony compounds.
4. E = Pb-free and Green
5. X suffix = Tape/Reel

IMPORTANT NOTICE

DIODES INCORPORATED MAKES NO WARRANTY OF ANY KIND, EXPRESS OR IMPLIED, WITH REGARDS TO THIS DOCUMENT, INCLUDING, BUT NOT LIMITED TO, THE IMPLIED WARRANTIES OF MERCHANTABILITY AND FITNESS FOR A PARTICULAR PURPOSE (AND THEIR EQUIVALENTS UNDER THE LAWS OF ANY JURISDICTION).

Diodes Incorporated and its subsidiaries reserve the right to make modifications, enhancements, improvements, corrections or other changes without further notice to this document and any product described herein. Diodes Incorporated does not assume any liability arising out of the application or use of this document or any product described herein; neither does Diodes Incorporated convey any license under its patent or trademark rights, nor the rights of others. Any Customer or user of this document or products described herein in such applications shall assume all risks of such use and will agree to hold Diodes Incorporated and all the companies whose products are represented on Diodes Incorporated website, harmless against all damages.

Diodes Incorporated does not warrant or accept any liability whatsoever in respect of any products purchased through unauthorized sales channel.

Should Customers purchase or use Diodes Incorporated products for any unintended or unauthorized application, Customers shall indemnify and hold Diodes Incorporated and its representatives harmless against all claims, damages, expenses, and attorney fees arising out of, directly or indirectly, any claim of personal injury or death associated with such unintended or unauthorized application.

Products described herein may be covered by one or more United States, international or foreign patents pending. Product names and markings noted herein may also be covered by one or more United States, international or foreign trademarks.

This document is written in English but may be translated into multiple languages for reference. Only the English version of this document is the final and definitive format released by Diodes Incorporated.

LIFE SUPPORT

Diodes Incorporated products are specifically not authorized for use as critical components in life support devices or systems without the express written approval of the Chief Executive Officer of Diodes Incorporated. As used herein:

A. Life support devices or systems are devices or systems which:

1. are intended to implant into the body, or
 2. support or sustain life and whose failure to perform when properly used in accordance with instructions for use provided in the labeling can be reasonably expected to result in significant injury to the user.
- B. A critical component is any component in a life support device or system whose failure to perform can be reasonably expected to cause the failure of the life support device or to affect its safety or effectiveness.

Customers represent that they have all necessary expertise in the safety and regulatory ramifications of their life support devices or systems, and acknowledge and agree that they are solely responsible for all legal, regulatory and safety-related requirements concerning their products and any use of Diodes Incorporated products in such safety-critical, life support devices or systems, notwithstanding any devices- or systems-related information or support that may be provided by Diodes Incorporated. Further, Customers must fully indemnify Diodes Incorporated and its representatives against any damages arising out of the use of Diodes Incorporated products in such safety-critical, life support devices or systems.

Copyright © 2016, Diodes Incorporated
www.diodes.com