

OAB400-22-1

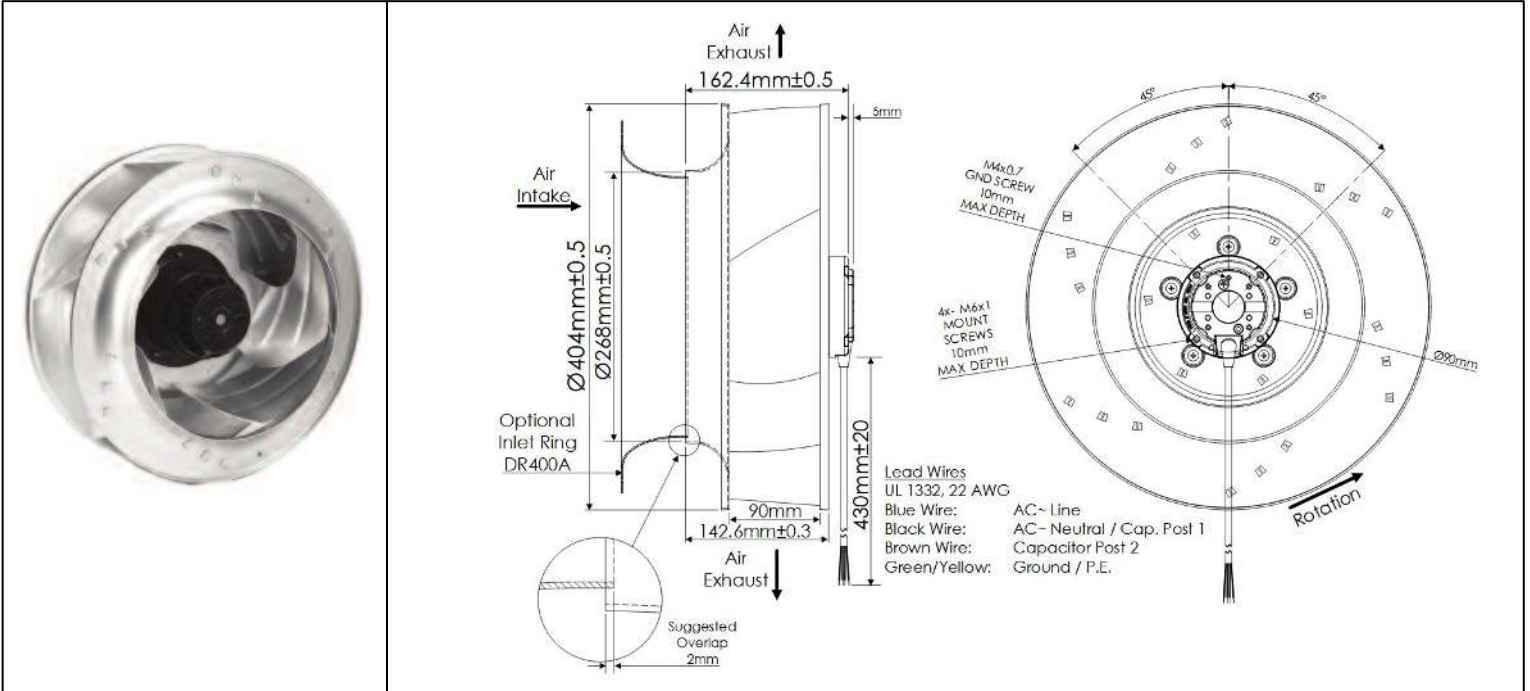

AC Centrifugal Fan - 230V 50Hz
404mm x 162mm (15.9" x 6.40")



Motor Housing	Die Cast Aluminum	<u>Operating Temperature</u> -40°C ~ +50°C	
Impeller	Aluminum Alloy	<u>Storage Temperature</u> -40°C ~ +80°C	
Connection	4x Lead Wires, UL 1332 22 AWG	<u>Life Expectancy</u> 40,000 Hours (L10 at 40°C)	
Motor	AC, Capacitor Induction, Thermally Protected, Class B Insulation, IP55	<u>Included Capacitors</u> 8uF/450V (-22-1 Model)	
Bearing System	Ball Bearings	<u>Recommended Accessories</u> DR400A Inlet Duct Ring	
Dielectric Strength	1500VAC/min, <5mA	Weight: 12 lbs.	
Insulation Resistance	≥10MΩ @ 500 VDC		

Part Number	Rated Voltage (Volts AC)	Voltage Range (Volts AC)	Frequency (Hertz)	Input Power (Watts)	Locked Current (Amps)	Rated Current (Amps)	Rated Speed (RPM)	Max Airflow (CFM)	Noise Level (dBA)	Max Static Pressure ("H ₂ O)
OAB400-22-1	230	200 ~ 250	50	287	1.70	1.26	1250	1900	73	1.9

Motor Wiring Diagram

