

### General Description

The ICS872S480 is a Zero Delay Clock Generator with hitless input clock switching capability. The ICS872S480 is ideal for use in redundant, fault tolerant clock trees where low jitter frequency synthesis are critical. The device receives two differential clock signals from which it generates two outputs with “zero” delay. The output and feedback dividers are configured to allow for a 1:1 frequency generation ratio.

The ICS872S480 Dynamic Clock Switch (DCS) circuit continuously monitors both input clock signals. Upon detection of an invalid clock input (stuck LOW or HIGH for at least one complete clock period of the VCO feedback frequency), the loss of reference monitor will be set HIGH. If that clock is the primary clock, the DCS will switch to the good secondary clock and phase/frequency alignment will occur with minimal output phase disturbance. Once the primary clock is restored to a good state, the DCS will automatically switch back to the primary clock input.

The low jitter characteristics with input clock monitoring and DCS capability make the ICS872S480 an ideal choice for DDR3 applications requiring fault tolerant reference clocks.

### Features

- Three differential HSTL output pairs
- Selectable differential CLKx, nCLKx input pairs
- CLKx, nCLKx pairs can accept the following differential input levels: LVPECL, LVDS, HSTL, HCSSL
- Output frequency range: 350MHz to 950MHz
- Input frequency range: 350MHz to 950MHz
- VCO range: 970MHz to 2250MHz
- External feedback for “zero delay” clock regeneration with configurable frequencies
- Static phase offset: ±100ps (maximum)
- Cycle-to-cycle jitter: 25ps (maximum)
- Output skew: 20ps (maximum)
- 3.3V operating voltage supply
- Selectable DDR3 or DDR3 low voltage output
- 0°C to 70°C ambient operating temperature
- Available in lead-free (RoHS 6) package

### Function Table

Input FREQ_SEL	Output Divider	Input & Output Frequency (MHz)	
		Minimum	Maximum
0	2	485	950
1 (default)	4	350	562.5

### Output Voltage Table

Input VOUT_SEL	HSTL Output Style
0 (default)	1.5V
1	1.35V

### Pin Assignment

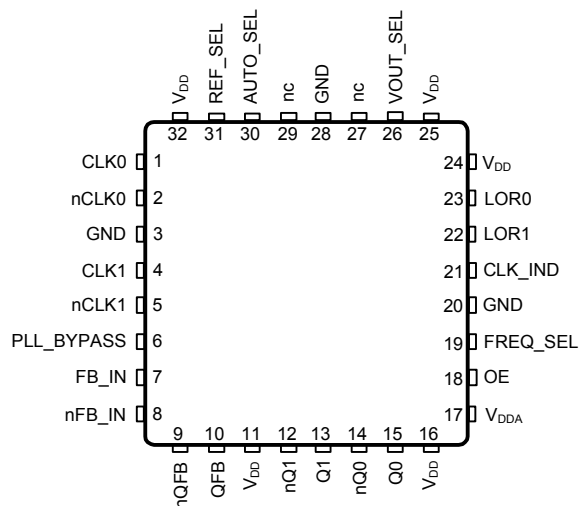

**ICS872S480**  
**32-Lead VFQFN**  
**5mm x 5mm x 0.925mm package body**  
**K Package**  
**Top View**

# Block Diagram

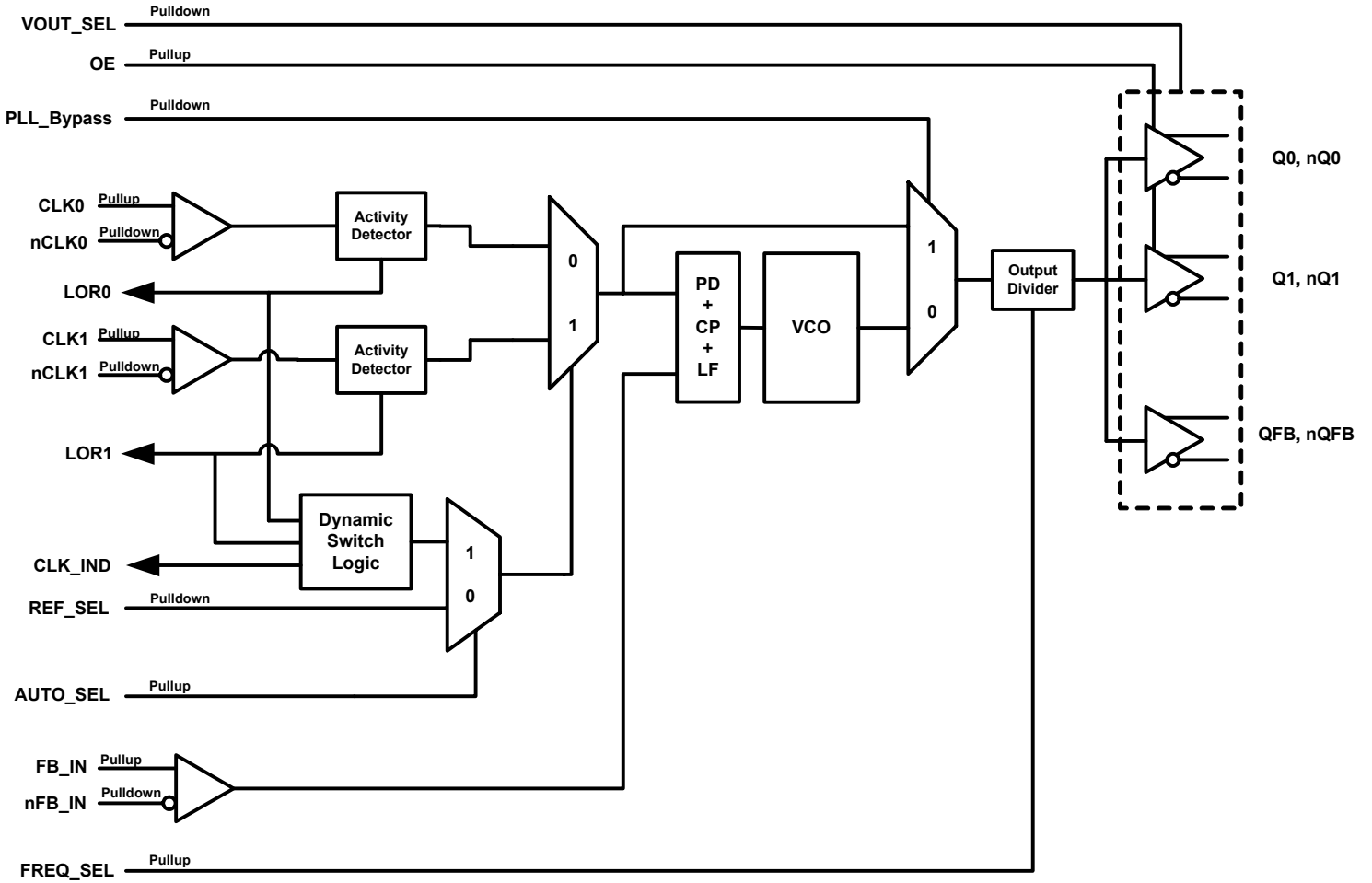

**Table 1. Pin Descriptions**

Number	Name	Type		Description
1	CLK0	Input	Pulldown	Non-inverting differential clock input.
2	nCLK0	Input	Pullup	Inverting differential clock input.
3, 20, 28	GND	Power		Power supply ground.
4	CLK1	Input	Pulldown	Non-inverting differential clock input.
5	nCLK1	Input	Pullup	Inverting differential clock input.
6	PLL_BYPASS	Input	Pulldown	PLL bypass pin. When HIGH, the PLL is bypassed and the reference clock is passed directly to the output dividers. LVCMOS/LVTTL interface levels.
7	FB_IN	Input	Pulldown	Non-inverting differential external feedback input.
8	nFB_IN	Input	Pullup	Inverting differential external feedback input.
9, 10	nQFB, QFB	Output		Differential feedback output pair. HSTL interface levels. See Table 4D.
11, 16, 24, 25, 32	V <sub>DD</sub>	Power		Core supply pins.
12, 13	nQ1, Q1	Output		Differential output pair. HSTL interface levels.
14, 15	nQ0, Q0	Output		Differential output pair. HSTL interface levels.
17	V <sub>DDA</sub>	Power		Analog supply pin.
18	OE	Input	Pullup	Output enable pin. LVCMOS/LVTTL interface levels.
19	FREQ_SEL	Input	Pullup	Frequency select pin. LVCMOS/LVTTL interface levels.
21	CLK_IND	Output		Clock indicator pin. When LOW, CLK0, nCLK0 is selected. When HIGH, CLK1, nCLK1 is selected.
22	LOR1	Output		Loss of Reference Indicator for CLK1, nCLK1. LVCMOS/LVTTL interface levels.
23	LOR0	Output		Loss of Reference Indicator for CLK0, nCLK0. LVCMOS/LVTTL interface levels.
26	VOUT_SEL	Input	Pulldown	Output voltage select pin. LVCMOS/LVTTL interface levels.
27, 29	nc	Unused		No connect.
30	AUTO_SEL	Input	Pullup	Dynamic Clock switch enable pin. When LOW, disables internal Dynamic Clock Switch circuitry and CLK_INDICATOR will track REF_SEL. When HIGH, Dynamic Clock Switch is enabled. LVCMOS/LVTTL interface levels.
31	REF_SEL	Input	Pulldown	Reference clock select pin. When LOW selects CLK0, nCLK0, when HIGH selects CLK1, nCLK1. LVCMOS/LVTTL interface levels.

NOTE: *Pullup and Pulldown* refer to internal input resistors. See Table 2, *Pin Characteristics*, for typical values.

**Table 2. Pin Characteristics**

Symbol	Parameter	Test Conditions	Minimum	Typical	Maximum	Units
C <sub>IN</sub>	Input Capacitance			2		pF
R <sub>PULLUP</sub>	Input Pullup Resistor			51		kΩ
R <sub>PULLDOWN</sub>	Input Pulldown Resistor			51		kΩ

## Absolute Maximum Ratings

NOTE: Stresses beyond those listed under *Absolute Maximum Ratings* may cause permanent damage to the device. These ratings are stress specifications only. Functional operation of product at these conditions or any conditions beyond those listed in the *DC Characteristics* or *AC Characteristics* is not implied. Exposure to absolute maximum rating conditions for extended periods may affect product reliability.

Item	Rating
Supply Voltage, $V_{DD}$	4.6V
Inputs, $V_I$	-0.5V to $V_{DD} + 0.5V$
Outputs, $V_O$	-0.5V to $V_{DD} + 0.5V$
Package Thermal Impedance, $\theta_{JA}$	42.7°C/W (0 mps)
Storage Temperature, $T_{STG}$	-65°C to 150°C

## DC Electrical Characteristics

**Table 4A. Power Supply DC Characteristics,  $V_{DD} = 3.3V \pm 5\%$ ,  $T_A = 0^\circ C$  to  $70^\circ C$**

Symbol	Parameter	Test Conditions	Minimum	Typical	Maximum	Units
$V_{DD}$	Core Supply Voltage		3.135	3.3	3.465	V
$V_{DDA}$	Analog Supply Voltage		$V_{DD} - 0.25$	3.3	$V_{DD}$	V
$I_{DD}$	Power Supply Current	Outputs terminated 50Ω to GND			275	mA
$I_{DDA}$	Analog Supply Current				25	mA

**Table 4B. LVCMOS/LVTTL DC Characteristics,  $V_{DD} = 3.3V \pm 5\%$ ,  $T_A = 0^\circ C$  to  $70^\circ C$**

Symbol	Parameter	Test Conditions	Minimum	Typical	Maximum	Units
$V_{IH}$	Input High Voltage		2.2		$V_{DD} + 0.3$	V
$V_{IL}$	Input Low Voltage		-0.3		0.8	V
$I_{IH}$	Input High Current	PLL_BYPASS, REF_SEL, VOUT_SEL	$V_{DD} = V_{IN} = 3.465V$		150	μA
		OE, FREQ_SEL, AUTO_SEL	$V_{DD} = V_{IN} = 3.465V$		10	μA
$I_{IL}$	Input Low Current	PLL_BYPASS, REF_SEL, VOUT_SEL	$V_{DD} = 3.465V, V_{IN} = 0V$	-10		μA
		OE, FREQ_SEL, AUTO_SEL	$V_{DD} = 3.465V, V_{IN} = 0V$	-150		μA

**Table 4C. Differential DC Characteristics,  $V_{DD} = 3.3V \pm 5\%$ ,  $T_A = 0^\circ C$  to  $70^\circ C$** 

Symbol	Parameter	Test Conditions	Minimum	Typical	Maximum	Units
$I_{IH}$	Input High Current	CLK0, CLK1, FB_IN	$V_{DD} = V_{IN} = 3.465V$		150	$\mu A$
		nCLK0, nCLK1, nFB_IN	$V_{DD} = V_{IN} = 3.465V$		10	$\mu A$
$I_{IL}$	Input Low Current	CLK0, CLK1, FB_IN	$V_{DD} = 3.465V, V_{IN} = 0V$	-10		$\mu A$
		nCLK0, nCLK1, nFB_IN	$V_{DD} = 3.465V, V_{IN} = 0V$	-150		$\mu A$
$V_{PP}$	Peak-to-Peak Voltage; NOTE 1		0.15		1.75	V
$V_{CMR}$	Common Mode Input Voltage; NOTE 1, 2		0.3		$V_{DD} - 0.85$	V

NOTE 1:  $V_{IL}$  should not be less than -0.3V.NOTE 2: Common mode input voltage is defined as  $V_{IH}$ .**Table 4D. HSTL DC Characteristics,  $V_{DD} = 3.3V \pm 5\%$ ,  $T_A = 0^\circ C$  to  $70^\circ C$** 

Symbol	Parameter	Test Conditions	Minimum	Typical	Maximum	Units
$V_{OX}$	Output Crosspoint Voltage, NOTE 1	VOUT_SEL = 0	0.7	0.8	0.9	V
		VOUT_SEL = 1	0.6	0.7	0.8	V
$V_{OD}$	Differential Output Voltage; NOTE 1	VOUT_SEL = 0	0.8	0.9	1.0	V
		VOUT_SEL = 1	0.8	0.9	1.0	V

NOTE 1: Outputs terminated with  $50\Omega$  to ground.**Table 5. Input Frequency Characteristics,  $V_{DD} = 3.3V \pm 5\%$ ,  $T_A = 0^\circ C$  to  $70^\circ C$** 

Symbol	Parameter	Test Conditions	Minimum	Typical	Maximum	Units	
$F_{IN}$	Input Frequency	CLK0, nCLK0, CLK1, nCLK1	FSEL = 1	485		950	MHz
			FSEL = 0	350		562.5	MHz

## AC Electrical Characteristics

**Table 6. AC Characteristics,  $V_{DD} = 3.3V \pm 5\%$ ,  $T_A = 0^\circ C$  to  $70^\circ C$**

Symbol	Parameter	Test Conditions	Minimum	Typical	Maximum	Units	
$f_{OUT}$	Output Frequency		350		950	MHz	
$t(\emptyset)$	Static Phase Offset; NOTE 1, 2	$f_{OUT} = 400MHz$	-25		75	ps	
		$f_{OUT} = 533.3MHz$	-50		50	ps	
		$f_{OUT} = 666.6MHz$	-50		50	ps	
		$f_{OUT} = 800MHz$	-50		50	ps	
$t_{dyn}(\emptyset)$	Dynamic Phase Offset; NOTE 7	$f_{OUT} = 400MHz$			$\pm 20$	ps	
		$f_{OUT} = 533.3MHz$			$\pm 25$	ps	
		$f_{OUT} = 666.6MHz$			$\pm 20$	ps	
		$f_{OUT} = 800MHz$			$\pm 20$	ps	
pdev	Output Period Deviation; NOTE 3, 7				100	ps	
tsk(o)	Output Skew; NOTE 2, 4				20	ps	
$\tau_{jit}(cc)$	Cycle-to-Cycle Jitter; NOTE 3, 7				25	ps	
$t_L$	PLL Lock Time; NOTE 7				3	ms	
$t_{Ldcs}$	DCS PLL Lock Time; NOTE 6, 7			1.7		$\mu s$	
$t_{SLEW}$	Output Slew Rate; NOTE 5	VOUT_SEL = 0	$f_{OUT} = 400MHz$	2.00	3.50	5.75	V/ns
			$f_{OUT} = 533.3MHz$	2.00	4.25	6.50	V/ns
			$f_{OUT} = 666.6MHz$	2.00	4.25	6.75	V/ns
			$f_{OUT} = 800MHz$	2.50	5.25	8.65	V/ns
		VOUT_SEL = 1	$f_{OUT} = 400MHz$	2.00	3.85	6.35	V/ns
			$f_{OUT} = 533.3MHz$	2.00	4.50	6.85	V/ns
			$f_{OUT} = 666.6MHz$	2.50	4.65	7.25	V/ns
			$f_{OUT} = 800MHz$	3.00	5.65	8.25	V/ns
odc	Output Duty Cycle		47		53	%	

NOTE: Electrical parameters are guaranteed over the specified ambient operating temperature range, which is established when the device is mounted in a test socket with maintained transverse airflow greater than 500 lpm. The device will meet specifications after thermal equilibrium has been reached under these conditions.

NOTE 1: Defined as the time difference between the input reference clock and the averaged feedback input signal across all conditions, when the PLL is locked and the input reference frequency is stable. Characterized using HSTL input level of 900mV, swing centered around 0.6V.

NOTE 2: This parameter is defined in accordance with JEDEC Standard 65.

NOTE 3: This parameter is defined as the maximum output period deviation during a dynamic switch event with reference inputs  $180^\circ$  out of phase. This does not factor in any cycle-to-cycle jitter seen on the input or output.

NOTE 4: Defined as skew between outputs at the same supply voltage and with equal load conditions. Measured at the output differential cross points.

NOTE 5: Output slew rate is measured at  $V_{OX} \pm 150mV$  for VOUT\_SEL = 0 and  $V_{OX} \pm 135mV$  for VOUT\_SEL = 1.

NOTE 6: This parameter is defined as PLL lock time after a dynamic switch event with reference inputs  $180^\circ$  out of phase.

NOTE 7: This parameter is guaranteed by characterization. Not tested in production.

### Parameter Measurement Information

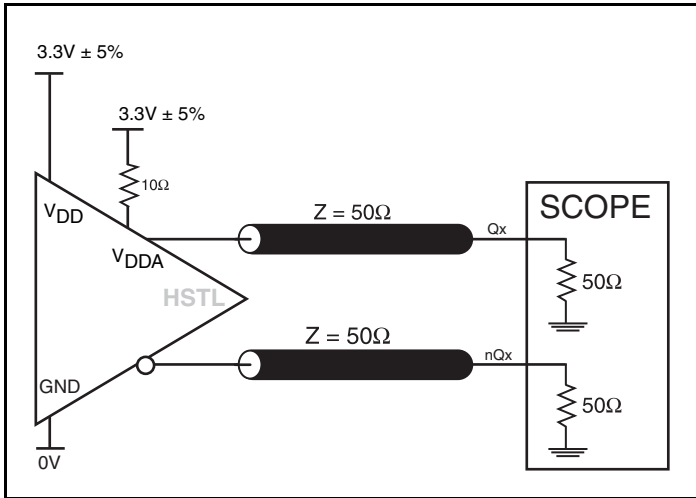

3.3V Output Load AC Test Circuit

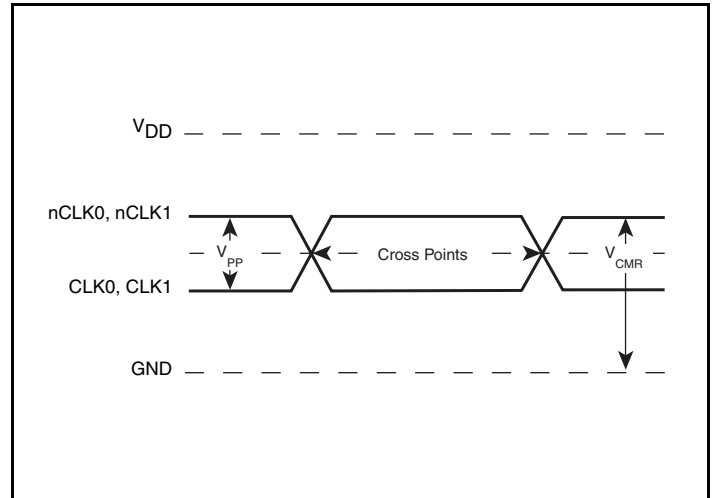

Differential Input Level

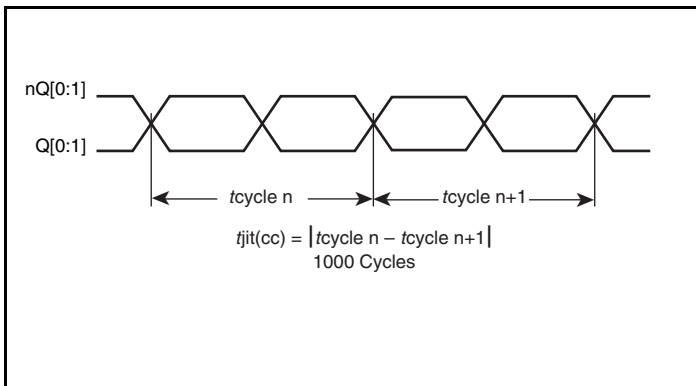

Cycle-to-Cycle Jitter

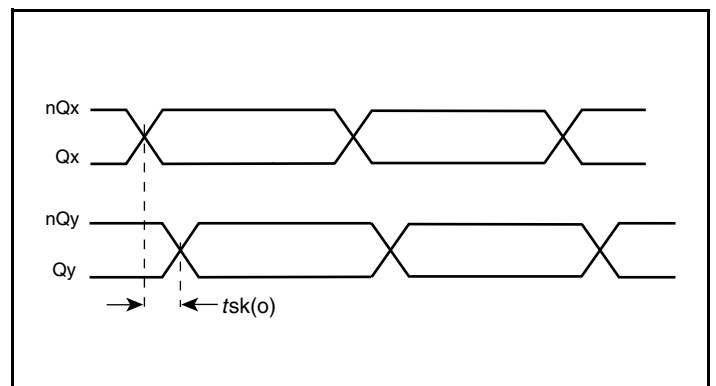

Output Skew

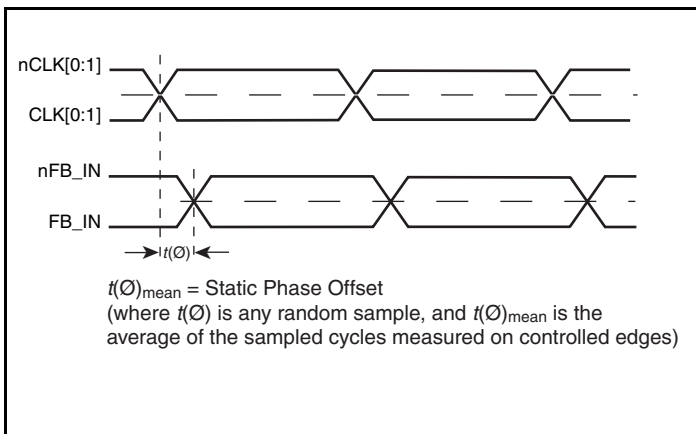

Static Phase Offset

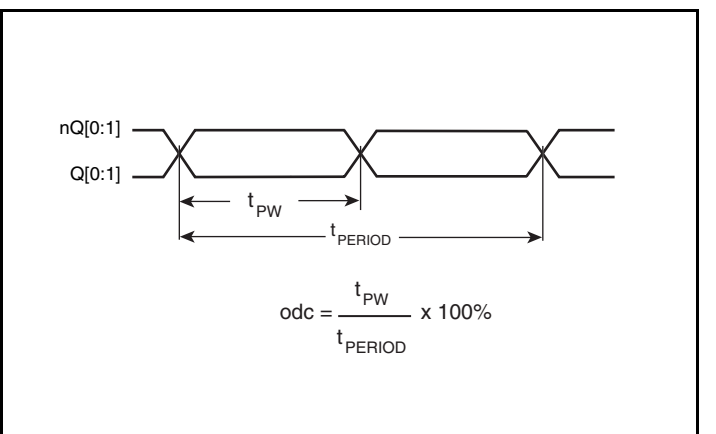

Output Duty Cycle/Pulse Width/Period

### Parameter Measurement Information, continued

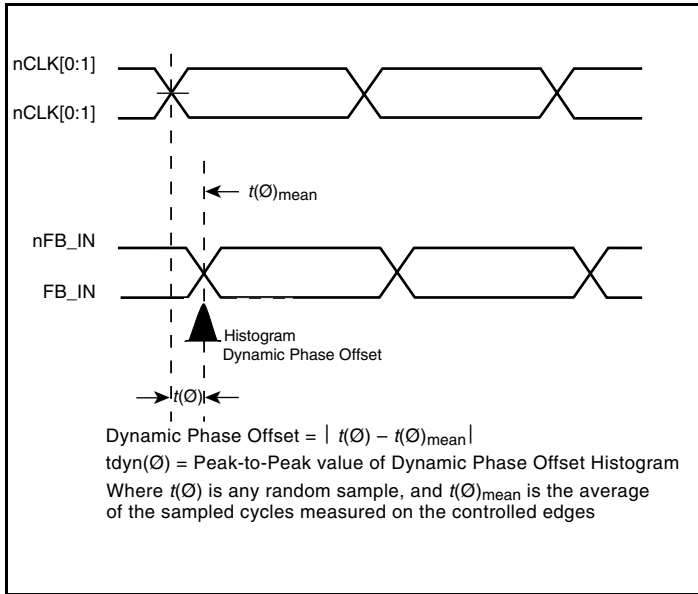

**Dynamic Phase Offset**

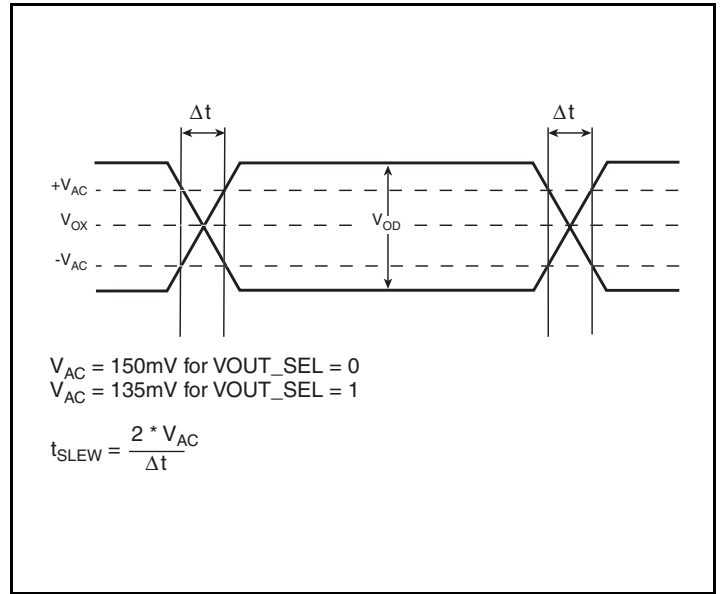

**Slew Rate**

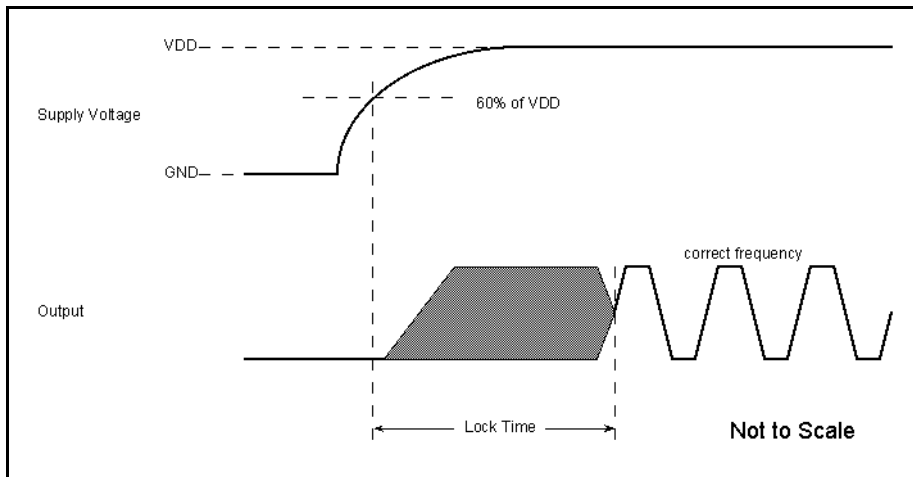

**PLL Lock Time**



## Applications Information

### Clock Redundancy and Reference Selection

The ICS872S480 accepts two differential input clocks, CLK0, nCLK0 and CLK1, nCLK1, for the purpose of redundancy. Only one of these clocks can be selected at any given time for use as the reference. CLK0, nCLK0 is defined as the initial, or primary clock, while the remaining clock is the redundant or secondary clock. The output signal CLK\_IND indicates which clock input is being used as the reference (LOW = CLK0, nCLK0, HIGH = CLK1, nCLK1).

### Failure Detection and Alarm Signaling

Within the ICS872S480 device, CLK0, nCLK0 and CLK1, nCLK1 are continuously monitored for failures. A failure on either of these clocks is detected when one of the clock signals is stuck HIGH or LOW for at least 1 period of the feedback. Upon detection of a failure, the corresponding loss-of-reference signal, LOR0 or LOR1, will be set HIGH. The input clocks are continuously monitored and the loss-of-reference signals will continue to reflect the real-time status of each input clock.

### Manual Clock Switching

When input signal AUTO\_SEL is driven LOW, the clock specified by REF\_SEL will always be used as the reference, even when a clock failure is detected at the reference. In order to switch between CLK0, nCLK0 and CLK1, nCLK1 as the reference clock, the level on REF\_SEL must be driven to the appropriate level. When the level on REF\_SEL is changed, the selection of the new clock will take place, and CLK\_IND will be updated to indicate which clock is now supplying the reference to the PLL.

### Dynamic Clock Switching

The Dynamic Clock Switching (DCS) process serves as an automatic safety mechanism to protect the stability of the PLL when a failure occurs on the reference.

When input signal AUTO\_SEL is not driven HIGH, an internal pullup pulls it HIGH so that DCS is enabled. If DCS is enabled and a failure occurs on the initial clock, the ICS872S480 device will check the status of the secondary clock. If the secondary clock is detected as a good input clock, the ICS872S480 will automatically de-select the initial clock as the reference and multiplex in the secondary clock. When a successful switch from the initial to secondary clock has been accomplished, CLK\_IND will be updated to indicate the new reference. If and when the fault on the initial clock is corrected, the corresponding loss-of-reference flag will be updated to represent this clock as good again. Once updated, the DCS will undergo an automatic clock switch. See the Dynamic Clock Switch State Diagram and for additional details on the functionality of the Dynamic Clock Switching circuit.

### Output Transitioning

After a successful DCS initiated clock switch, the internal PLL of the ICS872S480 will begin slewing to phase/frequency alignment of the newly selected clock input. The PLL will achieve lock to the new input with minimal phase disturbance at the outputs.

### Recommended Power-up Sequence

1. Before startup, set AUTO\_SEL low so the PLL will operate in manual switch mode, plus set REF\_SEL low to ensure that the primary reference clock, CLK0, nCLK0, is selected. This will ensure that during startup, the PLL will acquire lock using the primary reference clock input.
2. Once powered-up, and assuming a stable clock is present at the primary clock input, the PLL will begin to phase/frequency slew as it attempts to achieve lock with the input reference clock.
3. Drive AUTO\_SEL HIGH to enable DCS mode.

### Alternate Power-up Sequence

If both input clocks are valid before power up, the part may be powered-up in DCS mode. However, it cannot be guaranteed that the PLL will achieve lock with one specific input clock.

1. Before startup, leave AUTO\_SEL floating and the internal pullup will enable DCS mode.
2. Once powered up, the PLL will begin to phase/frequency slew as it attempts to achieve lock with one of the input reference clocks.

### State Diagram

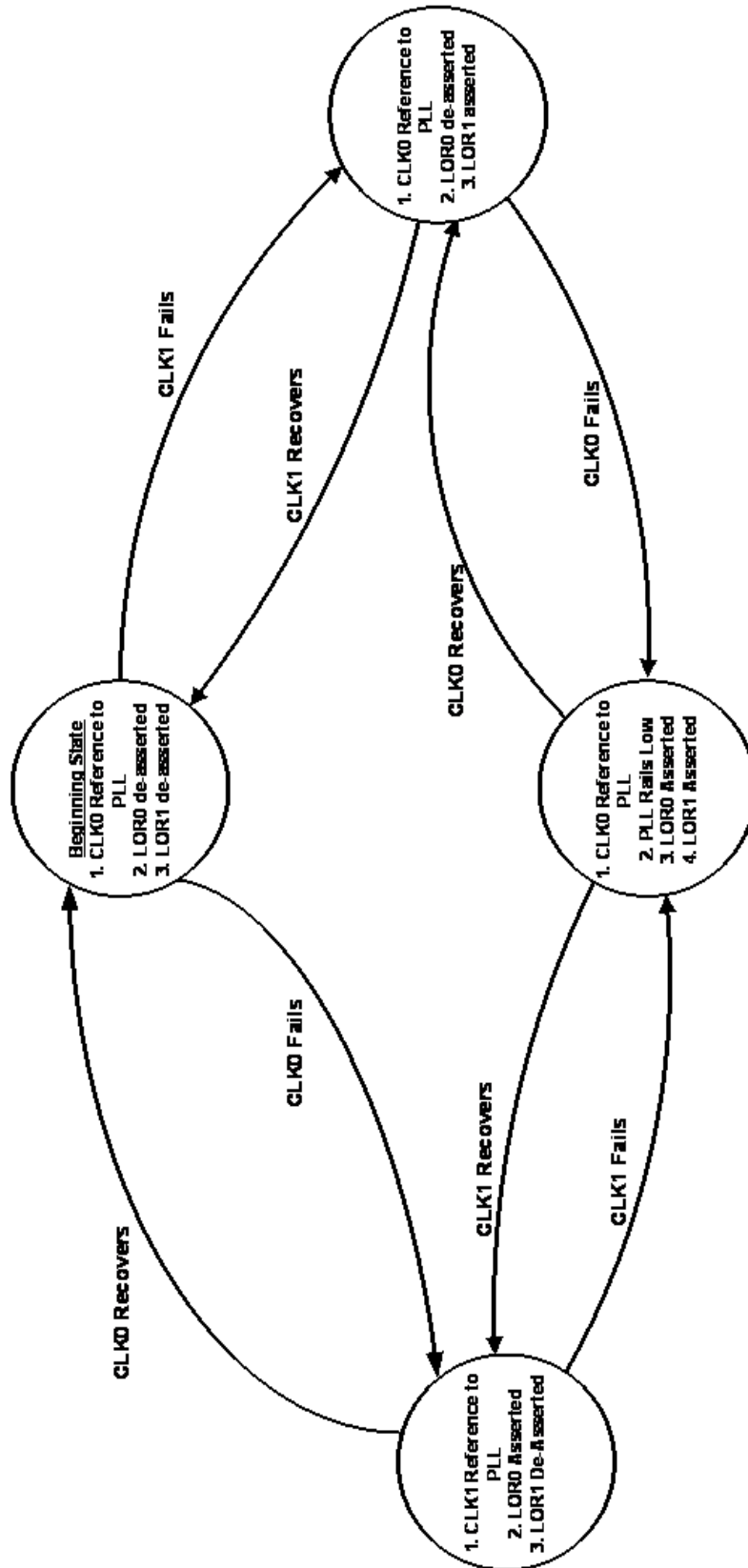

## Wiring the Differential Input to Accept Single-Ended Levels

Figure 1 shows how a differential input can be wired to accept single ended levels. The reference voltage  $V_{REF} = V_{DD}/2$  is generated by the bias resistors R1 and R2. The bypass capacitor (C1) is used to help filter noise on the DC bias. This bias circuit should be located as close to the input pin as possible. The ratio of R1 and R2 might need to be adjusted to position the  $V_{REF}$  in the center of the input voltage swing. For example, if the input clock swing is 2.5V and  $V_{DD} = 3.3V$ , R1 and R2 value should be adjusted to set  $V_{REF}$  at 1.25V. The values below are for when both the single ended swing and  $V_{DD}$  are at the same voltage. This configuration requires that the sum of the output impedance of the driver ( $R_o$ ) and the series resistance ( $R_s$ ) equals the transmission line impedance. In addition, matched termination at the input will attenuate the signal in half. This can be done in one of two ways. First, R3 and R4 in parallel should equal the transmission

line impedance. For most  $50\Omega$  applications, R3 and R4 can be  $100\Omega$ . The values of the resistors can be increased to reduce the loading for slower and weaker LVCMOS driver. When using single-ended signaling, the noise rejection benefits of differential signaling are reduced. Even though the differential input can handle full rail LVCMOS signaling, it is recommended that the amplitude be reduced. The datasheet specifies a lower differential amplitude, however this only applies to differential signals. For single-ended applications, the swing can be larger, however  $V_{IL}$  cannot be less than  $-0.3V$  and  $V_{IH}$  cannot be more than  $V_{DD} + 0.3V$ . Though some of the recommended components might not be used, the pads should be placed in the layout. They can be utilized for debugging purposes. The datasheet specifications are characterized and guaranteed by using a differential signal.

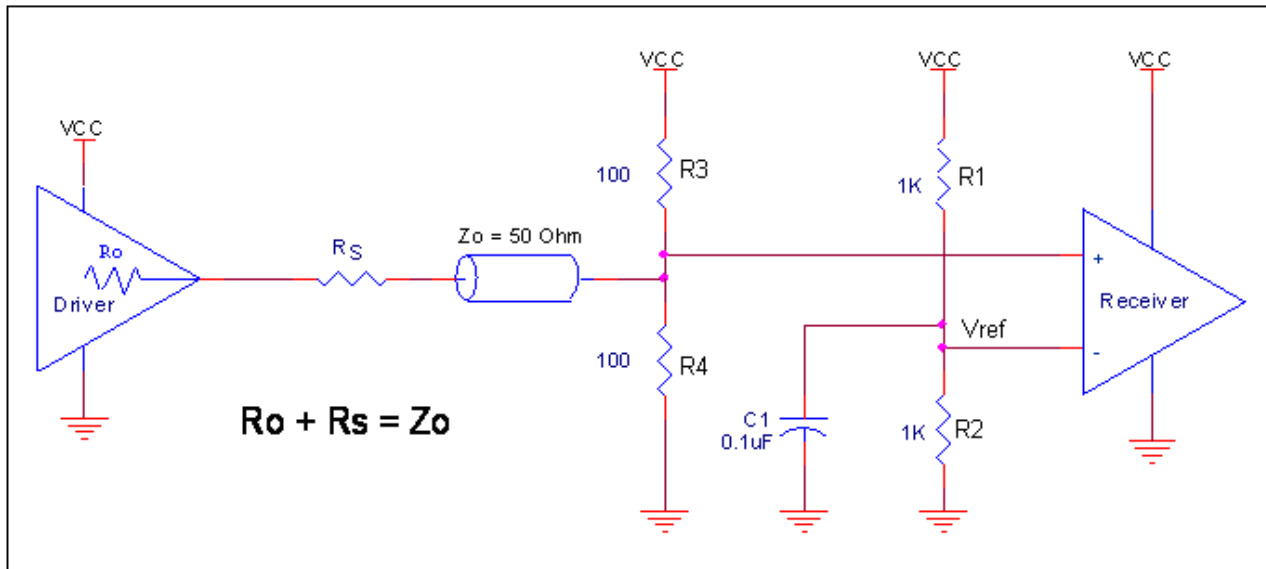
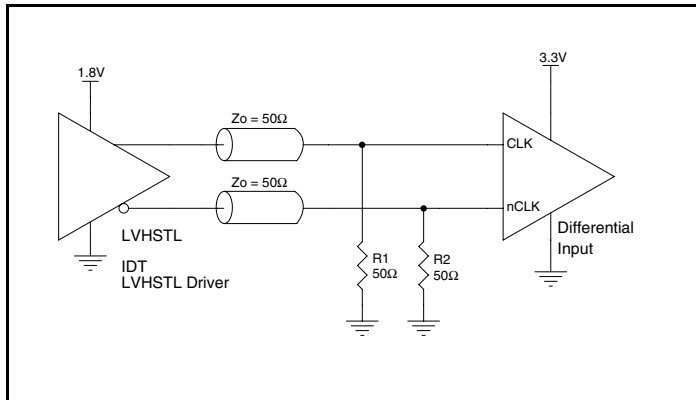

Figure 1. Recommended Schematic for Wiring a Differential Input to Accept Single-ended Levels

## Differential Clock Input Interface

The CLK /nCLK accepts LVDS, LVPECL, HSTL, HCSL and other differential signals. Both differential signals must meet the  $V_{PP}$  and  $V_{CMR}$  input requirements. *Figures 3A to 3E* show interface examples for the CLK/nCLK input driven by the most common driver types. The input interfaces suggested here are examples only. Please consult

with the vendor of the driver component to confirm the driver termination requirements. For example, in Figure 3A, the input termination applies for IDT open emitter HSTL drivers. If you are using an HSTL driver from another vendor, use their termination recommendation.



**Figure 3A. CLK/nCLK Input Driven by an IDT Open Emitter HSTL Driver**

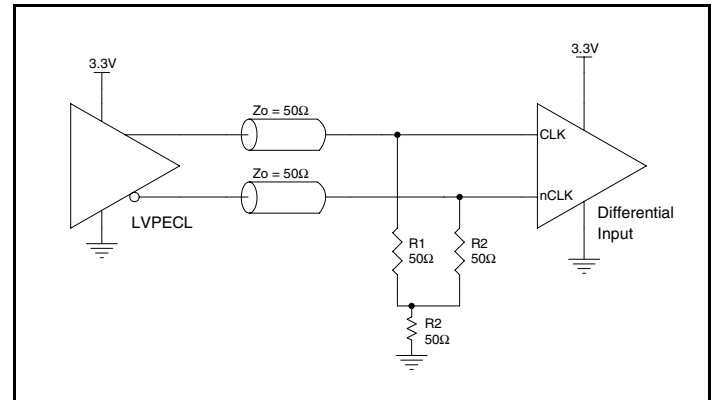

**Figure 3B. CLK/nCLK Input Driven by a 3.3V LVPECL Driver**

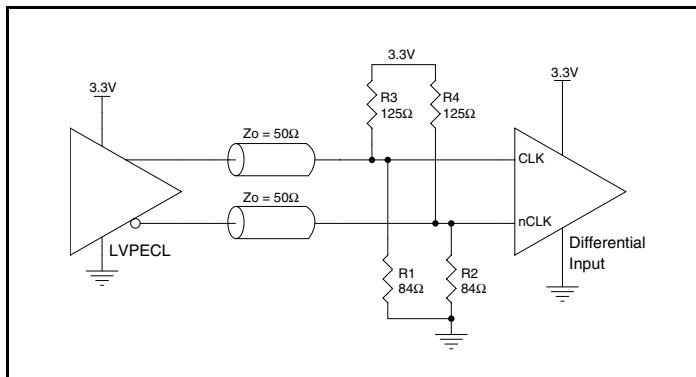

**Figure 3C. CLK/nCLK Input Driven by a 3.3V LVPECL Driver**

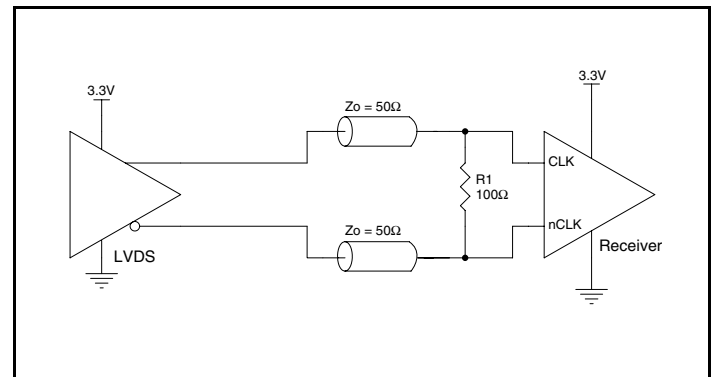

**Figure 3D. CLK/nCLK Input Driven by a 3.3V LVDS Driver**

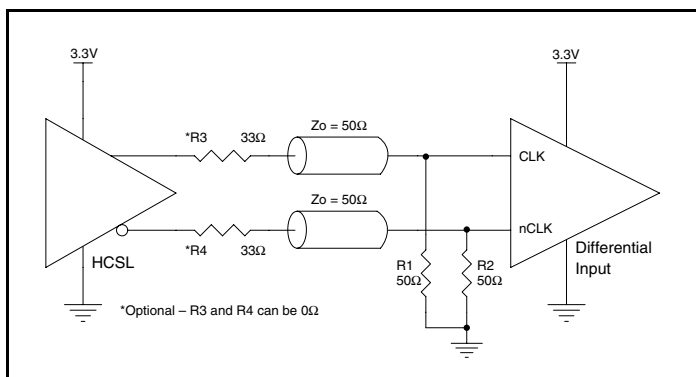

**Figure 3E. CLK/nCLK Input Driven by a 3.3V HCSL Driver**

## Recommendations for Unused Input Pins

### Inputs:

#### LVC MOS Control Pins

All control pins have internal pullups or pulldowns; additional resistance is not required but can be added for additional protection. A  $1\text{k}\Omega$  resistor can be used.

#### CLK/nCLK Inputs

For applications not requiring the use of the differential input, both CLK and nCLK can be left floating. Though not required, but for additional protection, a  $1\text{k}\Omega$  resistor can be tied from CLK to ground.

### Outputs:

#### HSTL Outputs

All unused HSTL outputs can be left floating. We recommend that there is no trace attached. Both sides of the differential output pair should either be left floating or terminated.

## HSTL Output Termination

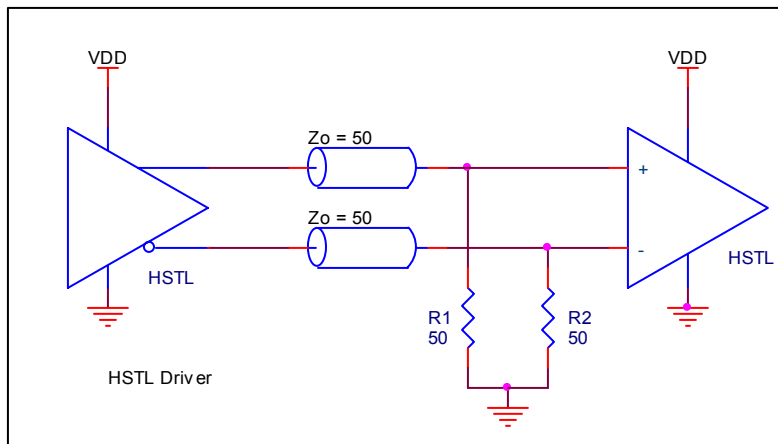

Figure 4. Output Termination

## VFQFN EPAD Thermal Release Path

In order to maximize both the removal of heat from the package and the electrical performance, a land pattern must be incorporated on the Printed Circuit Board (PCB) within the footprint of the package corresponding to the exposed metal pad or exposed heat slug on the package, as shown in *Figure 5*. The solderable area on the PCB, as defined by the solder mask, should be at least the same size/shape as the exposed pad/slug area on the package to maximize the thermal/electrical performance. Sufficient clearance should be designed on the PCB between the outer edges of the land pattern and the inner edges of pad pattern for the leads to avoid any shorts.

While the land pattern on the PCB provides a means of heat transfer and electrical grounding from the package to the board through a solder joint, thermal vias are necessary to effectively conduct from the surface of the PCB to the ground plane(s). The land pattern must be connected to ground through these vias. The vias act as “heat pipes”. The number of vias (i.e. “heat pipes”) are application specific

and dependent upon the package power dissipation as well as electrical conductivity requirements. Thus, thermal and electrical analysis and/or testing are recommended to determine the minimum number needed. Maximum thermal and electrical performance is achieved when an array of vias is incorporated in the land pattern. It is recommended to use as many vias connected to ground as possible. It is also recommended that the via diameter should be 12 to 13mils (0.30 to 0.33mm) with 1oz copper via barrel plating. This is desirable to avoid any solder wicking inside the via during the soldering process which may result in voids in solder between the exposed pad/slug and the thermal land. Precautions should be taken to eliminate any solder voids between the exposed heat slug and the land pattern. Note: These recommendations are to be used as a guideline only. For further information, please refer to the Application Note on the Surface Mount Assembly of Amkor’s Thermally/Electrically Enhance Leadframe Base Package, Amkor Technology.

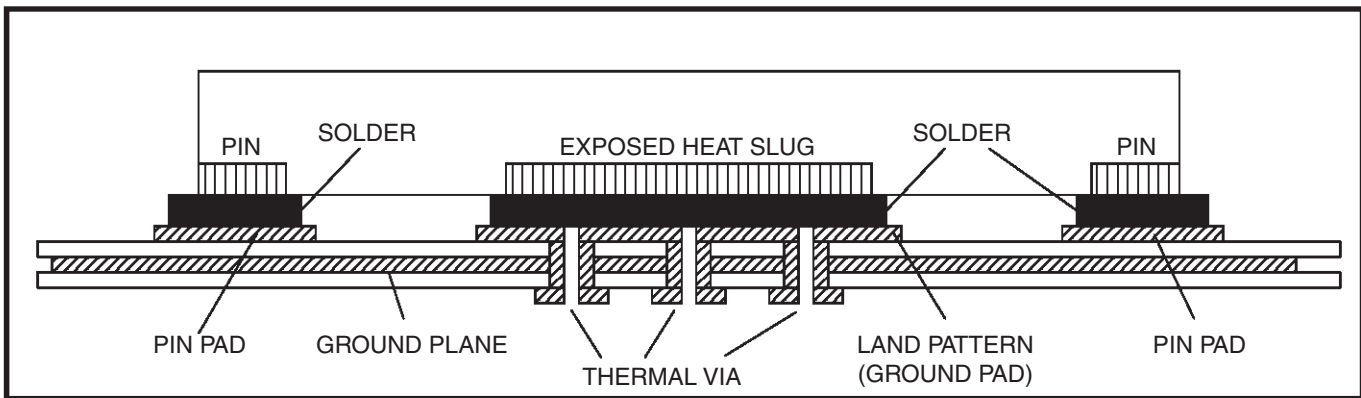

**Figure 5. P.C. Assembly for Exposed Pad Thermal Release Path – Side View (drawing not to scale)**

### Schematic Example

Figure 6 shows an example of ICS872S480 application schematic. In this example, the device is operated at  $V_{DD} = 3.3V$ . As with any high speed analog circuitry, the power supply pins are vulnerable to random noise. To achieve optimum jitter performance, power supply isolation is required. The ICS872S480 provides separate power supplies to isolate from coupling into the internal PLL.

In order to achieve the best possible filtering, it is recommended that the placement of the filter components be on the device side of the PCB as close to the power pins as possible. If space is limited, the 0.1uF capacitor in each power pin filter should be placed on the device side of the PCB and the other components can be placed on the opposite side.

Power supply filter recommendations are a general guideline to be used for reducing external noise from coupling into the devices. The filter performance is designed for a wide range of noise frequencies. This low-pass filter starts to attenuate noise at approximately 10kHz. If a specific frequency noise component is known, such as switching power supplies frequencies, it is recommended that component values be adjusted and if required, additional filtering be added. Additionally, good general design practices for power plane voltage stability suggests adding bulk capacitance in the local area of all devices.

The schematic example focuses on functional connections and is not configuration specific. Refer to the pin description and functional tables in the datasheet to ensure that the logic control inputs are properly set.

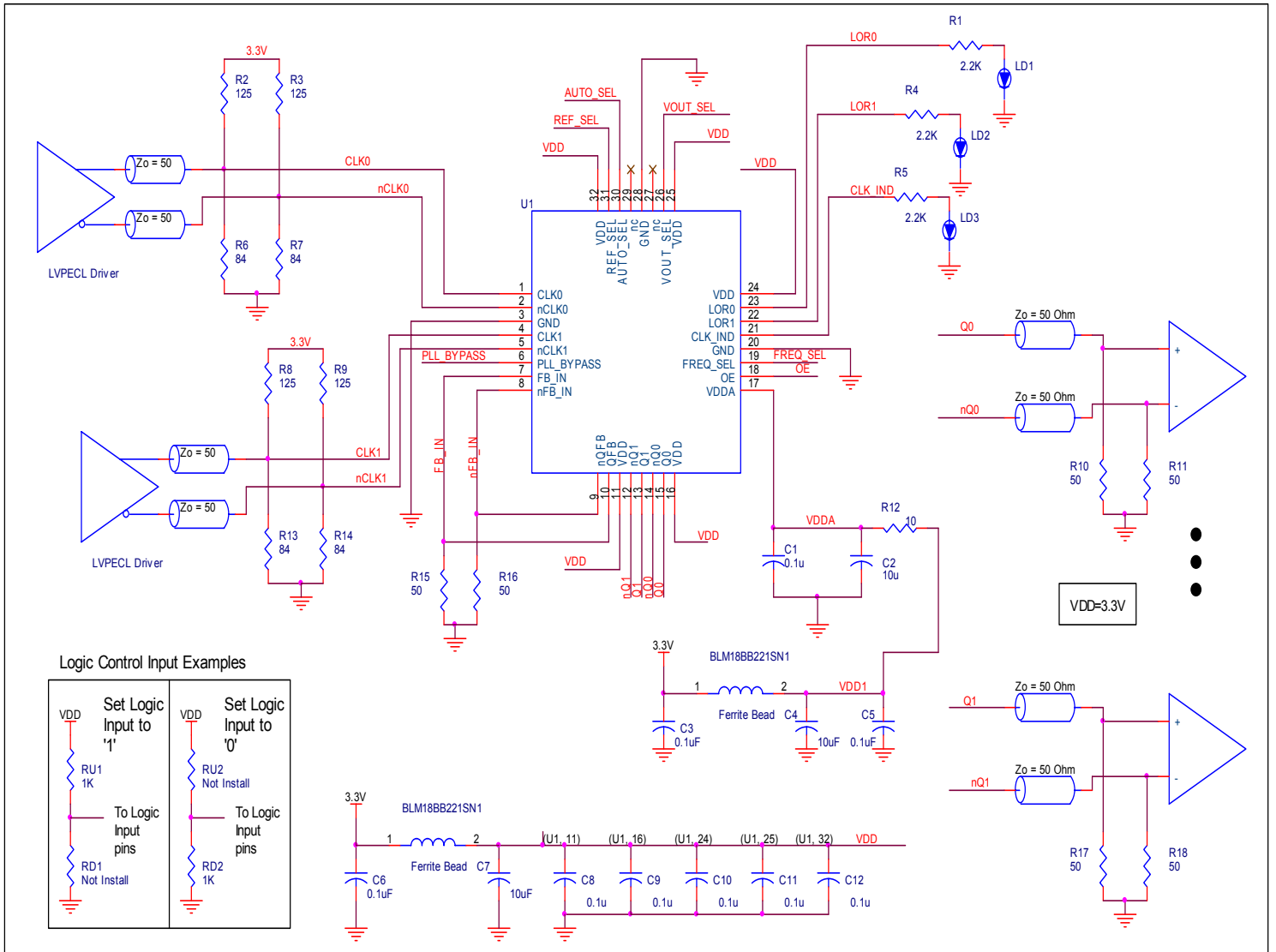

Figure 6. ICS872S480 Schematic Layout

## Power Considerations

This section provides information on power dissipation and junction temperature for the ICS872S480. Equations and example calculations are also provided.

### 1. Power Dissipation.

The total power dissipation for the ICS872S480 is the sum of the core power plus the power dissipated in the load(s). The following is the power dissipation for  $V_{DD} = 3.3V + 5\% = 3.465V$ , which gives worst case results.

- Power (core)<sub>MAX</sub> =  $V_{DD\_MAX} * (I_{DD\_MAX} + I_{DDA\_MAX}) = 3.465V * (275mA + 25mA) = 1039.5mW$

### 2. Junction Temperature.

Junction temperature,  $T_j$ , is the temperature at the junction of the bond wire and bond pad, and directly affects the reliability of the device. The maximum recommended junction temperature is 125°C. Limiting the internal transistor junction temperature,  $T_j$ , to 125°C ensures that the bond wire and bond pad temperature remains below 125°C.

The equation for  $T_j$  is as follows:  $T_j = \theta_{JA} * Pd\_total + T_A$

$T_j$  = Junction Temperature

$\theta_{JA}$  = Junction-to-Ambient Thermal Resistance

$Pd\_total$  = Total Device Power Dissipation (example calculation is in section 1 above)

$T_A$  = Ambient Temperature

In order to calculate junction temperature, the appropriate junction-to-ambient thermal resistance  $\theta_{JA}$  must be used. Assuming no air flow and a multi-layer board, the appropriate value is 42.7°C/W per Table 7 below.

Therefore,  $T_j$  for an ambient temperature of 70°C with all outputs switching is:

$$70^\circ\text{C} + 1.040\text{W} * 42.7^\circ\text{C/W} = 114.4^\circ\text{C}. \text{ This is below the limit of } 125^\circ\text{C}.$$

This calculation is only an example.  $T_j$  will obviously vary depending on the number of loaded outputs, supply voltage, air flow and the type of board (multi-layer).

**Table 7. Thermal Resistance  $\theta_{JA}$  for 32 Lead VFQFN, Forced Convection**

$\theta_{JA}$ vs. Air Flow			
Meters per Second	0	1	2.5
Multi-Layer PCB, JEDEC Standard Test Boards	42.7°C/W	37.3°C/W	33.5°C/W



## Reliability Information

**Table 8.  $\theta_{JA}$  vs. Air Flow Table for a 32-lead VFQFN**

$\theta_{JA}$ vs. Air Flow			
Meters per Second	0	1	2.5
Multi-Layer PCB, JEDEC Standard Test Boards	42.7°C/W	37.3°C/W	33.5°C/W

## Transistor Count

The transistor count for ICS872S480 is: 2110

## Package Outline and Package Dimensions

### Package Outline - K Suffix for 32 Lead VFQFN

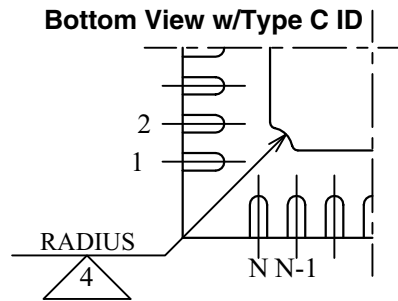
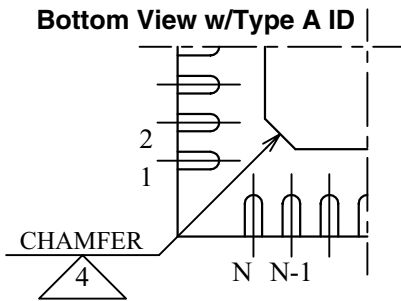
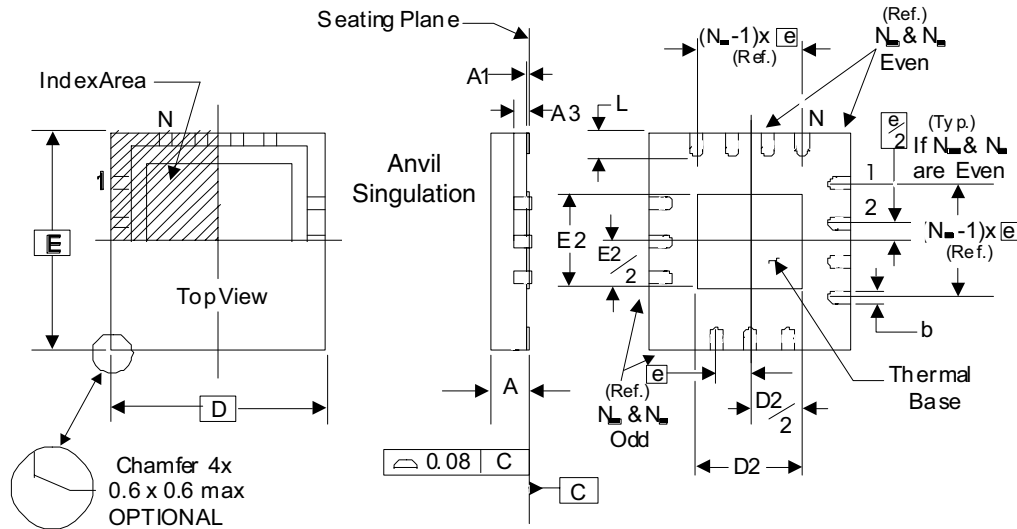

There are 2 methods of indicating pin 1 corner at the back of the VFQFN package are:

1. Type A: Chamfer on the paddle (near pin 1)
2. Type C: Mouse bite on the paddle (near pin 1)

**Table 9. Package Dimensions**

JEDEC Variation: VHHD-2/-4			
All Dimensions in Millimeters			
Symbol	Minimum	Nominal	Maximum
N		32	
A	0.80		1.00
A1	0		0.05
A3		0.25 Ref.	
b	0.18	0.25	0.30
N <sub>D</sub> & N <sub>E</sub>			8
D & E		5.00 Basic	
D2 & E2	3.0		3.3
e		0.50 Basic	
L	0.30	0.40	0.50

Reference Document: JEDEC Publication 95, MO-220

NOTE: The following package mechanical drawing is a generic drawing that applies to any pin count VFQFN package. This drawing is not intended to convey the actual pin count or pin layout of this device. The pin count and pinout are shown on the front page. The package dimensions are in Table 9.

## Ordering Information

**Table 10. Ordering Information**

Part/Order Number	Marking	Package	Shipping Packaging	Temperature
872S480BKLF	ICS72S480BL	"Lead-Free" 32 Lead VFQFN	Tray	0°C to 70°C
872S480BKLFT	ICS72S480BL	"Lead-Free" 32 Lead VFQFN	2500 Tape & Reel	0°C to 70°C

NOTE: Parts that are ordered with an "LF" suffix to the part number are the Pb-Free configuration and are RoHS compliant.

While the information presented herein has been checked for both accuracy and reliability, Integrated Device Technology (IDT) assumes no responsibility for either its use or for the infringement of any patents or other rights of third parties, which would result from its use. No other circuits, patents, or licenses are implied. This product is intended for use in normal commercial applications. Any other applications, such as those requiring extended temperature ranges, high reliability or other extraordinary environmental requirements are not recommended without additional processing by IDT. IDT reserves the right to change any circuitry or specifications without notice. IDT does not authorize or warrant any IDT product for use in life support devices or critical medical instruments.

## We've Got Your Timing Solution



6024 Silver Creek Valley Road  
San Jose, California 95138

**Sales**  
800-345-7015 (inside USA)  
+408-284-8200 (outside USA)  
Fax: 408-284-2775  
[www.IDT.com/go/contactIDT](http://www.IDT.com/go/contactIDT)

**Technical Support**  
[netcom@idt.com](mailto:netcom@idt.com)  
+480-763-2056

DISCLAIMER Integrated Device Technology, Inc. (IDT) and its subsidiaries reserve the right to modify the products and/or specifications described herein at any time and at IDT's sole discretion. All information in this document, including descriptions of product features and performance, is subject to change without notice. Performance specifications and the operating parameters of the described products are determined in the independent state and are not guaranteed to perform the same way when installed in customer products. The information contained herein is provided without representation or warranty of any kind, whether express or implied, including, but not limited to, the suitability of IDT's products for any particular purpose, an implied warranty of merchantability, or non-infringement of the intellectual property rights of others. This document is presented only as a guide and does not convey any license under intellectual property rights of IDT or any third parties.

IDT's products are not intended for use in life support systems or similar devices where the failure or malfunction of an IDT product can be reasonably expected to significantly affect the health or safety of users. Anyone using an IDT product in such a manner does so at their own risk, absent an express, written agreement by IDT.

Integrated Device Technology, IDT and the IDT logo are registered trademarks of IDT. Other trademarks and service marks used herein, including protected names, logos and designs, are the property of IDT or their respective third party owners.

Copyright 2011. All rights reserved.