

REV.	DATE	DESCRIPTION	BY	C'K'D'
B	2004-01-28	104-0005	BKP	BKP
C	2005-10-22	105-0196	ALEX B	BKP
D	2006-07-04	106-0096	YIVEK	BKP
05	2001-05-31	BEC 9.3525	R.M.	

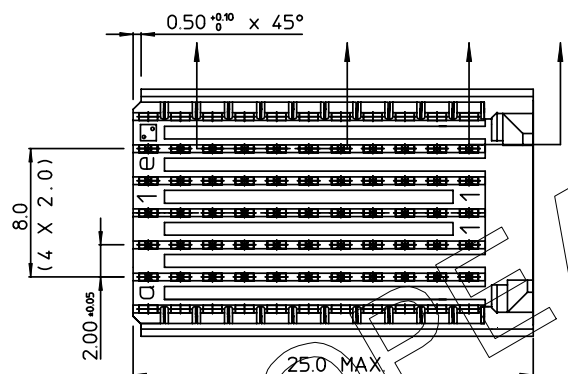

LAY-OUT  
P.C.B. - HOLE

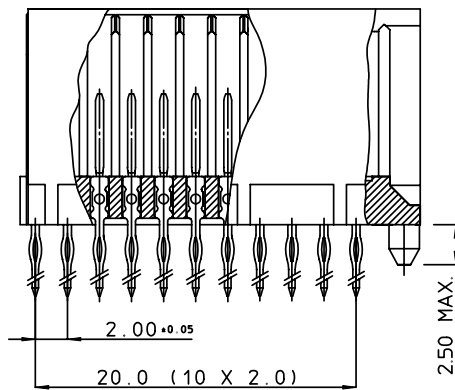
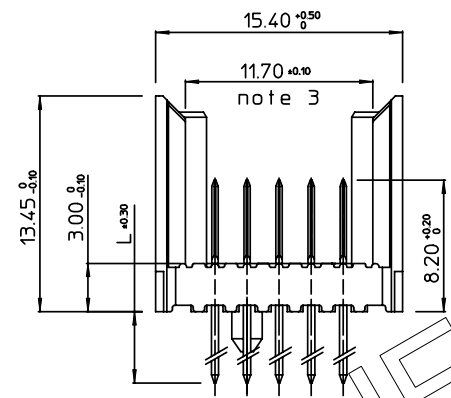
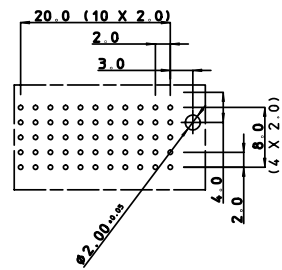

PERFORMANCE CHARACTERISTICS

CURRENT RATING : 1.5 A AT 20°C ( FULLY LOADED )  
 1 A AT 70°C ( FULLY LOADED )  
 RATED VOLTAGE : 500 V AC ( CONT / CONT )  
 OPERATING TEMPERATURE : -55°C TO 125°C  
 CONTACT RESISTANCE : 20 mΩ MAX  
 INSERTION FORCE : 0.75 N MAX / CONT  
 EXTRACTION FORCE : 0.15 N MIN / CONT  
 INSULATION RESISTANCE : 10<sup>4</sup> MΩ MIN

CAT. NR	L ± 0.3	DESCRIPTION
HM2P09PD5110----	3.7	SHORT PRESS-FIT
HM2P09PC5110----	4.5	SHORT PRESS-FIT
HM2P09PK5110----	13	REAR PLUG-UP: LEVEL 1
HM2P09PM5110----	14.5	REAR PLUG-UP: LEVEL 2
HM2P09PN5110----	16	REAR PLUG-UP: LEVEL 3
HM2P09PT5110----	13	WIRE WRAP

NOTES

- \*HM2P09P#5110---" LEAD FREE INDICATOR : LF=LEAD FREE (DIGIT 15&16)
- THIS PRODUCT IS CSA APPROVED.  
THIS PRODUCT IS UL RECOGNIZED.
- MEASURED AT THE BOTTOM.
- FOR RECOMMENDED PTH DIMENSIONS REFER DRAWING : BS.A ,201572,001
- THE PRODUCT (LF) MEETS EUROPEAN UNION DIRECTIVES AND OTHER COUNTRY REGULATIONS AS DESCRIBED IN GS-22-008

MALE SIGNAL STRAIGHT PRESS-FIT-TO-BOARD CONNECTOR

EXTENSION MODULE (WIDE BODY)			
1DEC ± 0,2	APPR.	DATE	SIGN.
2DEC ± 0,1	DRAFT	1993-06-08	W.Panis
ANGLES ± 1°	CHECKED		
WE RESERVE THE RIGHT TO CHANGE DIMENSIONS OR REQUIREMENTS WITHOUT PRIOR NOTICE.	PROD. MGR.		
	PR. ENG. MGR.		
	PR. MGT. MGR.		
ALL DIMENSIONS IN MM	MILLIPACS 2 / TYPE C / NO SHIELDING		CAT. No. HM2P09P#5110----
	www.fciconnect.com		SCALE 3/1

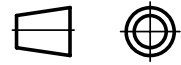

REFERENCES

BS,C ,201632,003 D

THIS IS OUR EXCLUSIVE PROPERTY. IT IS NOT TO BE COPIED, REPRINTED OR DISCLOSED TO A THIRD PARTY, NOR USED FOR MANUFACTURING WITHOUT OUR WRITTEN CONSENT, AND HAS TO BE RETURNED TO US IN CASE OF NO USAGE

DIT IS ONZE EIGENDOM EN MAG NIET NAGEMAAKT, HERDRUKT, OVERGEMAAKT AAN DERDEN, NOCH VOOR FABRIKATIE GEBRUIKT WORDEN, ZONDER ONZE SCHRIFTELIJKE TOELATING. BIJ NIET GEBRUIK IS TERUGZENDING VERPLICHT.