

IrDA™ Board

Manual

All Mikroelektronika's development systems feature a large number of peripheral modules expanding microcontroller's range of application and making the process of program testing easier. In addition to these modules, it is also possible to use numerous additional modules linked to the development system through the I/O port connectors. Some of these additional modules can operate as stand-alone devices without being connected to the microcontroller.

Additional Board

 **MikroElektronika**

SOFTWARE AND HARDWARE SOLUTIONS FOR EMBEDDED WORLD ...making it simple

IrDA Additional Board

The *IrDA* additional board is used for wireless communication carried out via infrared waves. This board includes an infrared transceiver module TFDU4101 used for serial communication with devices transferring data via infrared waves such as printers, fax machines, notebooks, industrial devices, etc. The MCP2155 circuit provided on the board is used to convert data received from the transceiver module and send it to the microcontroller for further processing. The *IrDA* board communicates with a microcontroller via serial communication UART.

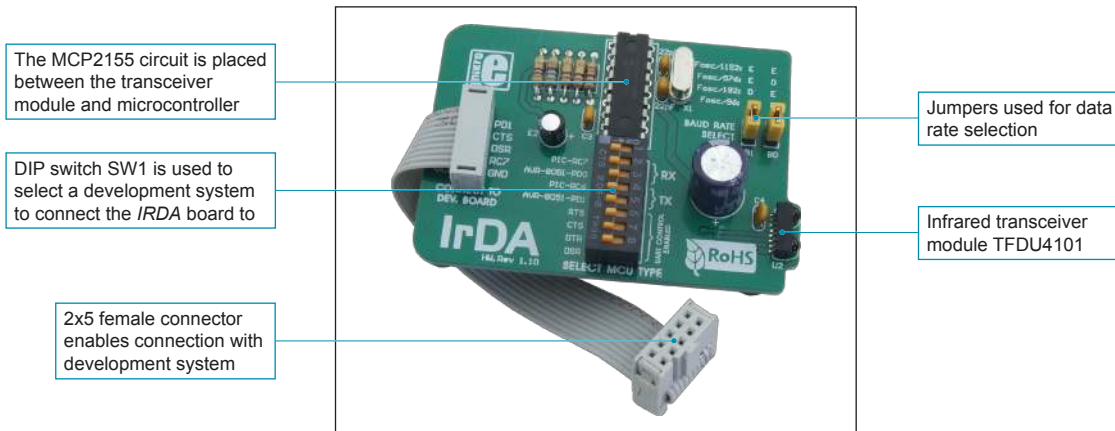

Figure 1: IrDA board

The TFDU4101 infrared transceiver module can send and receive data in the scope of over 1m at a rate of up to 115.2kbit/s. The data rate depends on the MCP2155 circuit and position of jumpers B1 and B0. Refer to the table on the right. DIP switch SW1 is used to select a development system to be connected to the additional board, Figure 2.

Data rate selection		
Jumper position		Data rate
B1	B0	
E	E	9.6 kbit/s
E	D	19.2 kbit/s
D	E	57.6 kbit/s
D	D	115.2 kbit/s

Labels used in the table have the following meaning:

- E - Jumper is placed (Enable)
- D - Jumper is removed (Disable)

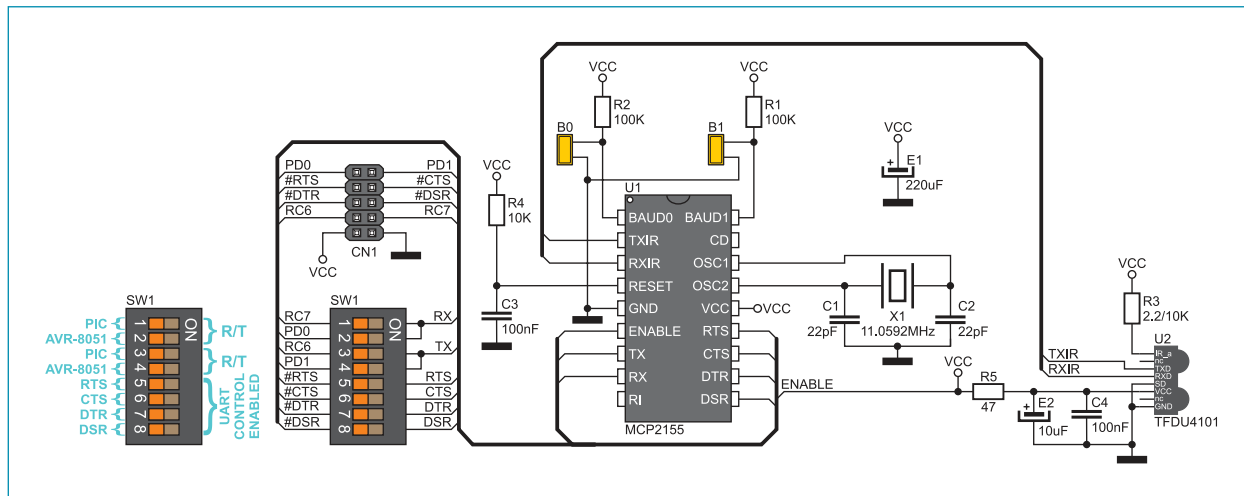

Figure 2: Additional board IrDA connection schematic

The function of the pins provided on the 2x5 female connector CN1:

- RC7 - Receive data pin RX for PIC development systems
- RC6 - Transmit data pin TX for PIC development systems
- PD0 - Receive data pin RX for AVR and 8051 development systems
- PD1 - Transmit data pin TX for AVR and 8051 development systems
- RTS - Request to send
- CTS - Clear to send
- DTR - Data terminal ready
- DSR - Data set ready

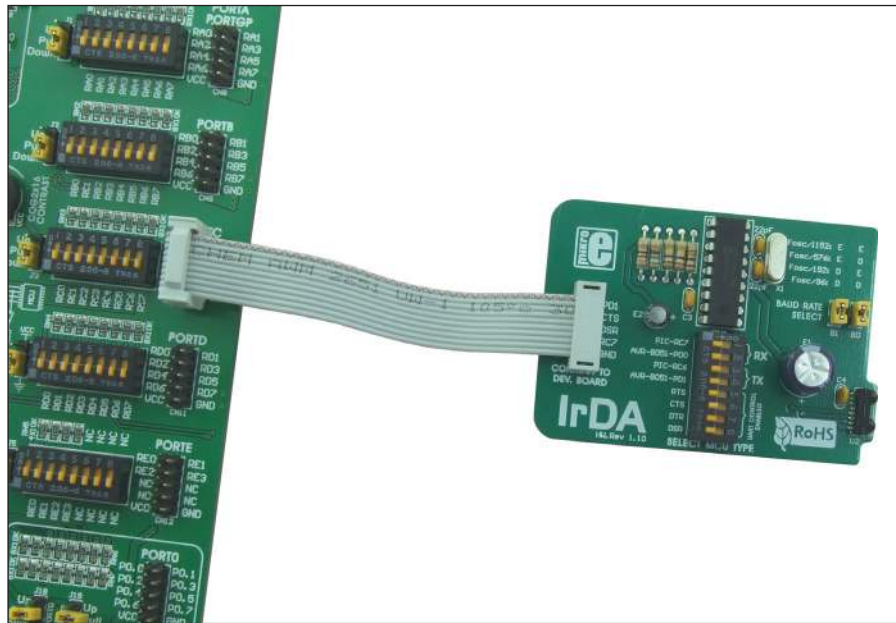

Figure 3: IrDA board connected to a development system



MikroElektronika
SOFTWARE AND HARDWARE SOLUTIONS FOR EMBEDDED WORLD ...making it simple

If you want to learn more about our products, please visit our website at www.mikroe.com

If you are experiencing some problems with any of our products or just need additional information, please place your ticket at www.mikroe.com/en/support

If you have any questions, comments or business proposals, do not hesitate to contact us at office@mikroe.com