

PART NUMBER	REV	FIRST USED
680333-1	A	122500-1
680333-2	A	565435-5

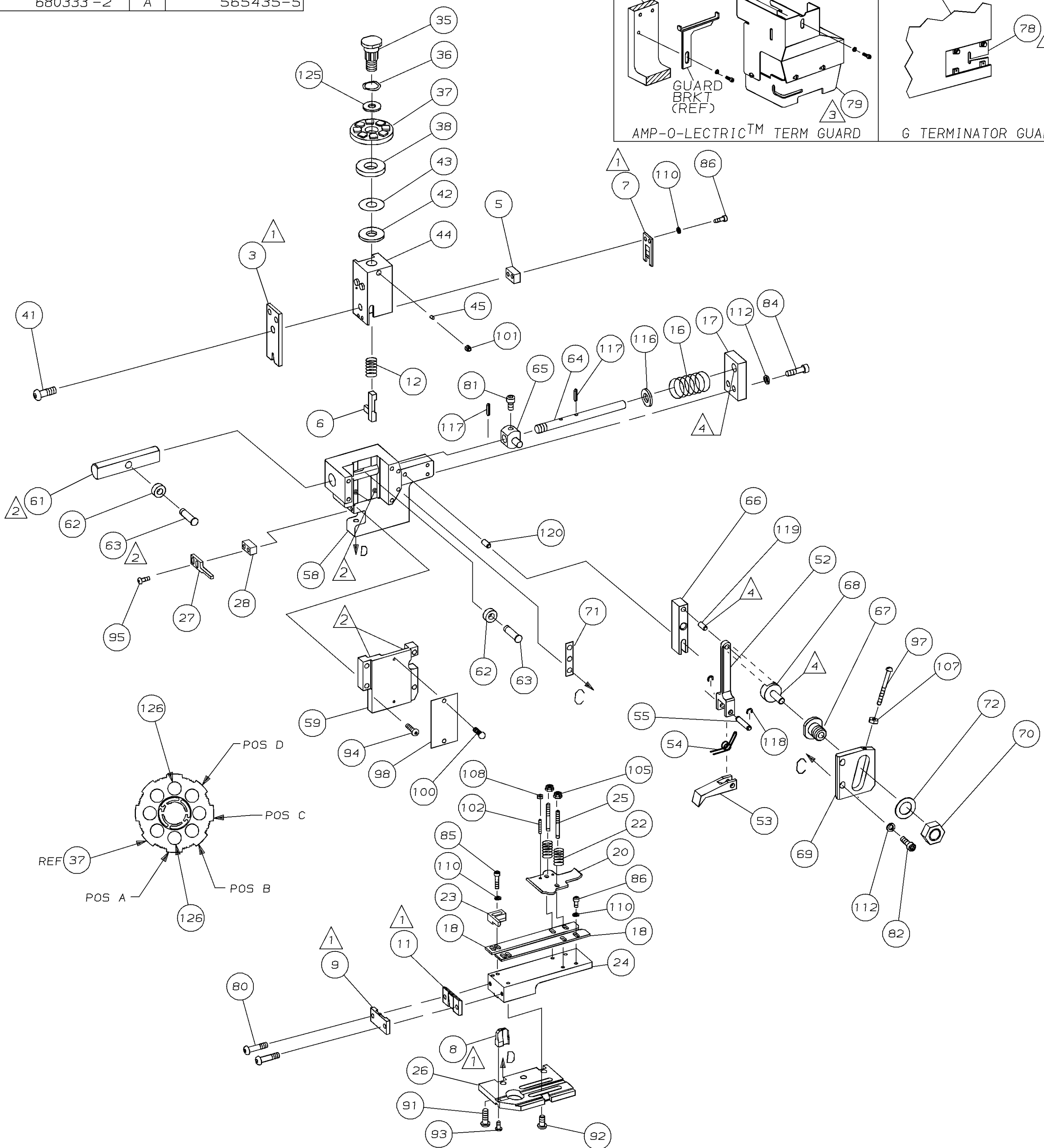
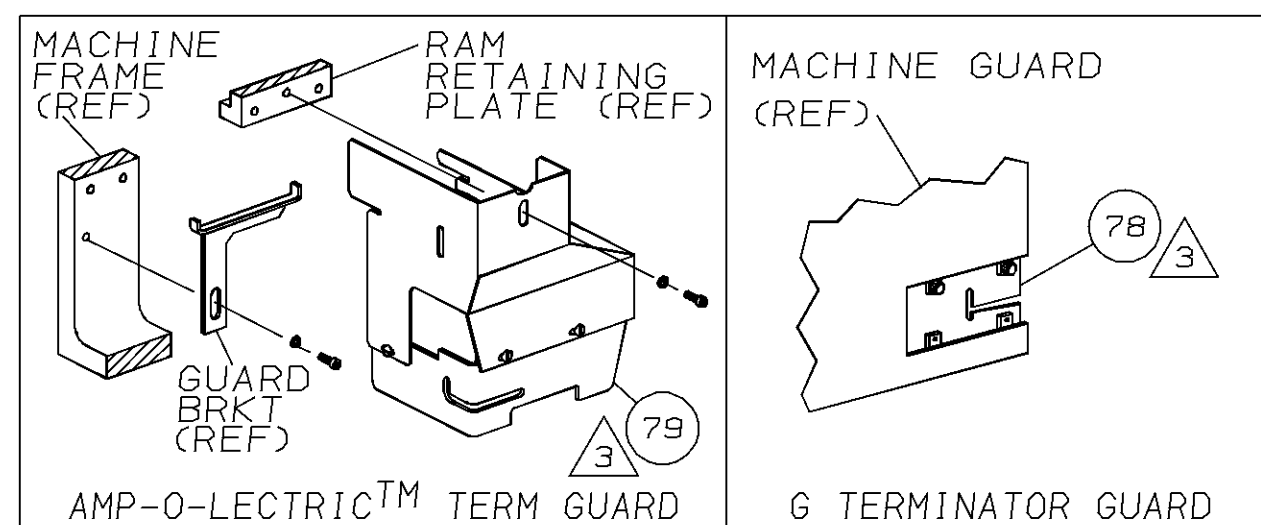

TERMINAL NAME: PIN, INSULATION PIERCING .109					
61674					
CRIMPING DATA					
PAD LTR	CRIMP HEIGHT	WIRE SIZE			
A	.073 ±.002 [1.85 ±0.05mm]	-			
B	NOT	USED			
C	NOT	USED			
D	NOT	USED			
CRIMP	SIZE	TYPE	RANGE		
WIRE	-	-	-		
INSUL	.130 [3.30mm]	BLUNT F	-		
WIRE STRIP LENGTH	TERM APPL SPEC	FEED	APPL INSTRUCTION	SET UP GAGE	LAYOUT
-	114-02080	.655	408-8039	458638-1	L1791

					129	
					128	
					127	
2	2	-	C	8-354778-3	PIN, WIRE DISC (.2910)A	126
1	1	-	A	986950-1	WASHER, FLAT PRECISION	125
1	1	-	A	217238-1	GENERAL INSTRUCTION PACKAGE	124
1	1	-	-	4088039	EF APPL INST 408-8039	123
					122	
					121	
REF	REF	-	A	1-21030-7	PIN, DOWEL (Ø.187x1.50) HSG	120
REF	REF	-	A	1-21030-1	PIN, DOWEL (Ø.187x.50) LEVER	119
REF	REF	-	A	21045-3	RING, RET "C" (Ø.187) FD PIN	118
REF	REF	-	A	5-21028-1	PIN, STD SPRING (Ø.12) FD ADJ ROD	117
REF	REF	-	A	21899-4	WASHER, FLAT (Ø5/16) SCR ADJ	116
					115	
					114	
					113	
REF	REF	-	A	21024-5	WASHER, LOCK (NO.10) FD ROD GDE	112
7	7	-	A	21024-4	WASHER, LOCK (NO.8) SHEAR BL	110
					109	
2	2	-	A	21018-4	NUT, HEX (4-40) DRAG	108
REF	REF	-	A	21018-5	NUT, HEX (6-32) FD ADJ PL	107
					106	
2	2	-	A	21022-2	NUT, HEX SL (8-32) DRAG STUD	105
					104	
					103	
2	2	-	A	2-21006-6	SCR, SKT SET (4-40x.62) DRAG	102
1	1	-	A	21009-2	SCR, SKT SET (1/4-20x.25) RAM	101
2	2	-	A	21017-2	SCR, DRIVE (#2x.19) ID PLATE	100
1	1	-	A	1-21002-7	SCR, BHC (6-32x.38) CAM	99
1	1	-	B	461264-1	PLATE, IDENTIFICATION	98
REF	REF	-	A	6-23715-5	SCR, PAN HD (6-32x1.50) FEED ADJ	97
					96	
2	2	-	A	2-21002-2	SCR, BHC (8-32x.50) STRIPPER	95
REF	REF	-	A	2-21002-9	SCR, BHC (10-32x.75) HSG CAP	94
1	1	-	A	22733-8	SCR, BHC (8-32x.38 LW) ANVIL	93
4	4	-	A	3-21002-3	SCR, BHC (1/4-20x.50) ST ØD PL	92
REF	REF	-	A	2-22733-8	SCR, BHC (1/4-20x.62) BASE PL	91
					90	
					89	
					88	
					87	
5	5	-	A	2-21000-6	SCR, SHC (8-32x.38) STRIP GUIDE	86
2	2	-	A	2-21000-9	SCR, SHC (8-32x.75) R STRIP GUIDE	85
REF	REF	-	A	3-21000-7	SCR, SHC (10-32x.75) FEED ROD GDE	84
					83	
REF	REF	-	A	3-21000-6	SCR, SHC (10-32x.62) FEED ADJ PL	82
REF	REF	-	A	3-21000-4	SCR, SHC (10-32x.38) PIVOT BLOCK	81
2	2	-	A	3-21002-0	SCR, BHC (10-32x.88) SHEAR PL	80
REF	-	-	A	455745-1	GUARD, WINDOW	79
-	REF	-	A	679532-1	INSERT, GUARD	78
					77	
					76	
					75	
					74	
					73	
REF	REF	-	A	458109-1	WASHER, FLAT (SPECIAL)	72
REF	REF	-	A	690517-1	SPACER	71

-1		LEADMAKER & BENCH MODEL G	MECH POST FEED			
-2		BENCH MODEL K	MECH POST FEED			
REF	REF	-	A	22594-8	NUT, HEX	70
REF	REF	-	B	240628-1	PLATE, ADJ	69
REF	REF	-	B	240626-1	SHAFT, PIVOT	68
REF	REF	-	B	240633-1	BUSHING	67
REF	REF	-	A	455680-1	LEVER, INTERMEDIATE	66
REF	REF	-	B	240629-1	BLOCK, PIVOT	65
REF	REF	-	A	240632-2	SCR, ADJ	64
REF	REF	-	B	240659-3	PIN, CAM ROLLER	63
REF	REF	-	B	240658-1	CAM, ROLLER	62
REF	REF	-	B	454398-1	ROD, FEED	61
					60	
REF	REF	-	C	454220-1	CAP, RAM	59
REF	REF	-	D	453736-1	HOUSING	58
					57	
					56	
REF	REF	-	B	240624-1	PIN, FEED FINGER	55
REF	REF	-	B	691499-1	SPRING, FEED FINGER	54
REF	REF	-	B	240635-1	FINGER, FEED	53
REF	REF	-	B	240634-1	LEVER, TERMINAL	52
					51	
					50	
					49	
1	-	-	B	690501-3	CAM, POST FEED 1 1/8 ST	48
-	1	-	B	690501-4	CAM, POST-FEED 1 5/8 ST	47
					46	
1	1	-	A	690191-1	PLUG, NYLON	45
1	1	-	C	455674-1	RAM	44
1	1	-	A	690125-1	WASHER, LAMINATED	43
1	1	-	A	690124-1	WASHER, RAM	42
1	1	-	A	7-21002-9	BOLT, CRIMPER (5/16-24x1.00)	41
					40	
					39	
1	1	-	A	690223-2	SPACER, INSULATION DISC	38
1	1	-	D	354777-1	WIRE DISC, PLASTIC	37
1	1	-	A	22480-5	WASHER, SPRING	36
1	1	-	B	690212-1	POST, RAM	35
					34	
					33	
1	1	-	D	458980-1	APPLICATOR, BASIC (SUB ASSY)	32
					31	
					30	
					29	
1	1	-	B	3-690451-2	SPACER, STRIPPER	28
1	1	-	A	240639-1	STRIPPER	27
REF	REF	-	C	455676-1	PLATE, BASE	26
2	2	-	A	22354-8	DRAG, STUD	25
1	1	-	B	455678-6	PLATE, STRIP GUIDE	24
1	1	-	C	240825-6	PLATE, STRIP HOLD DOWN	23
2	2	-	A	4-22281-1	SPRING, DRAG	22
					21	
1	1	-	A	454177-1	DRAG, STOCK	20
					19	
2	2	-	C	454204-3	GUIDE, STRIP (FRONT)	18
REF	REF	-	A	454178-1	GUIDE, FEED ROD	17
REF	REF	-	A	4-22284-9	SPRING, FEED RETURN	16
					15	
					14	
					13	
1	1	-	A	23846-1	SPRING, HOLD DOWN	12
1	1	-	B	1-240833-0	PLATE, REAR SHEAR	11
					10	
1	1	-	B	318713-1	PLATE, FRONT SHEAR	9
1	1	-	D	454435-5	ANVIL	8
1	1	-	B	690474-6	BLADE, SLUG	7
1	1	-	D	1-455892-0	HOLD DOWN, TERMINAL	6
1	1	-	C	240641-6	SPACER, SLUG BLADE	5
					4	
1	1	-	C	1-459585-5	CRIMPER, INSULATION	3
					2	
					1	

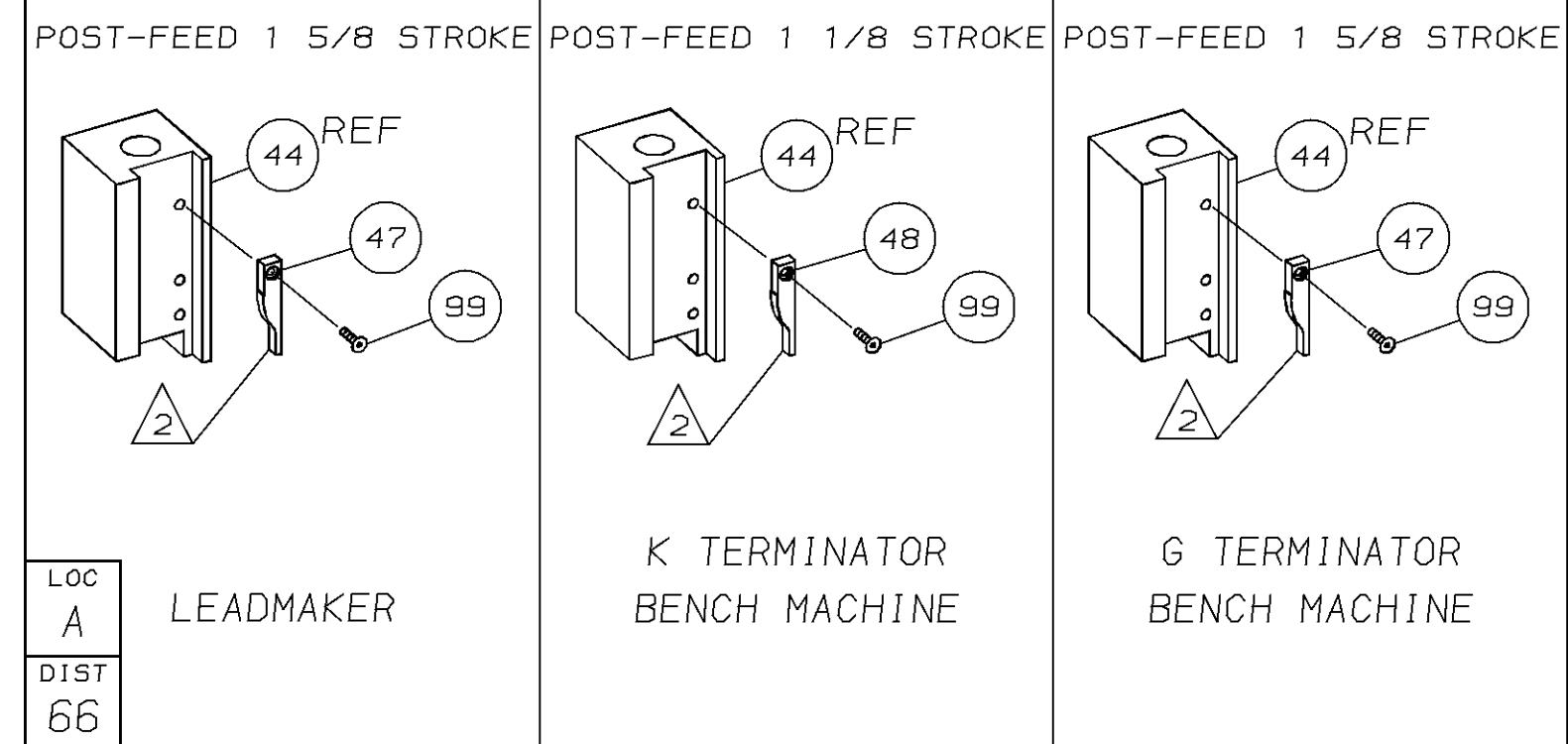

- 1 RECOMMENDED SPARE PARTS.
- 2 GREASE LIGHTLY.
- 3 GUARD MUST BE IN PLACE WHEN OPERATING APPLICATOR IN A BENCH MACHINE.
- 4 LUBRICATE DAILY USING NO. 20 MACHINE OIL.
- 5. ITEMS WITH QTY OF REF SPECIFIED (EXCEPT ITEMS 78 AND 79) ARE USED ON ITEM 32.
- 6 ITEM 78 USED WITH G TERMINATOR ONLY.

THIS INFORMATION IS CONFIDENTIAL AND IS DISCLOSED TO YOU ON CONDITION THAT NO FURTHER DISCLOSURE IS MADE BY YOU TO OTHER THAN AMP PERSONNEL WITHOUT WRITTEN AUTHORIZATION FROM AMP INCORPORATED, HARRISBURG, PA.

THIS DRAWING IS A CONTROLLED DOCUMENT FOR AMP INCORPORATED. IT IS SUBJECT TO CHANGE AND THE CONTROLLING ENGINEERING ORGANIZATION SHOULD BE CONTACTED FOR THE LATEST REVISION.