

THIS DRAWING IS UNPUBLISHED. RELEASED FOR PUBLICATION 20
 © COPYRIGHT 20 BY TYCO ELECTRONICS CORPORATION. ALL RIGHTS RESERVED.

LOC	DIST	REVISIONS			
P	LTR	DESCRIPTION	DATE	DWN	APVD
ES	00				
	A4	REVISED ECR-08-009797	16MAY08	AZ	SY
	B	REVISED PER ECO-11-005032	11MAR2011	JY	CW

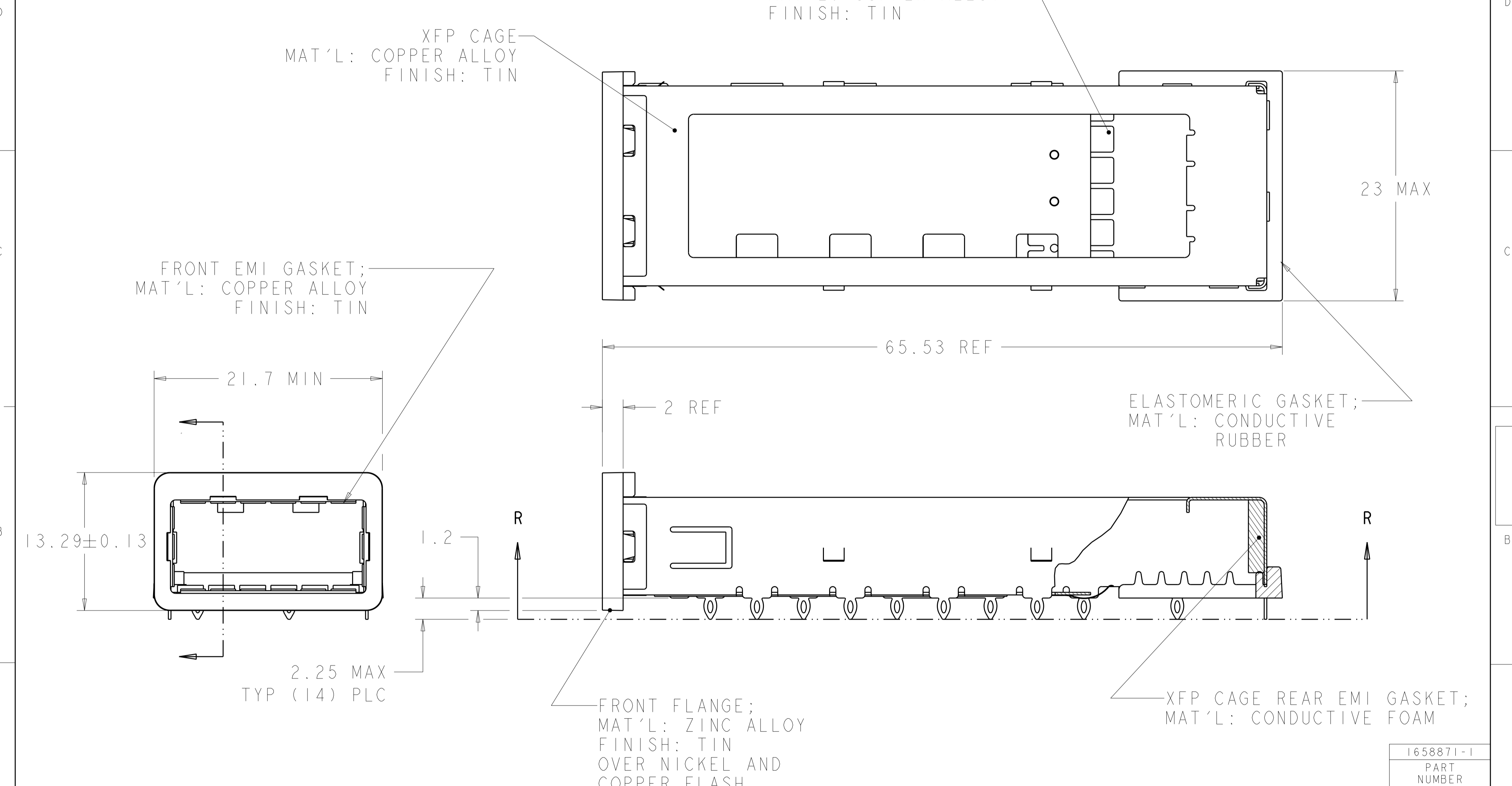

1658871-1
 PART NUMBER

<small>THIS DRAWING IS A CONTROLLED DOCUMENT FOR TYCO ELECTRONICS CORPORATION IT IS SUBJECT TO CHANGE AND THE CONTROLLING ENGINEERING ORGANIZATION SHOULD BE CONTACTED FOR THE LATEST REVISION.</small>		DWN D.E.STAHL 20NOV03 CHK E.BRIGHT 20NOV03 APVD E.BRIGHT 20NOV03	Tyco Electronics Tyco Electronics Shanghai, China	
DIMENSIONS: mm 		PRODUCT SPEC 108-2127 APPLICATION SPEC 114-13096 WEIGHT -	NAME ASSEMBLY, XFP CAGE WITH INSULATING TAPE	
TOLERANCES UNLESS OTHERWISE SPECIFIED: 0 PLC ± 1 PLC ±.1 2 PLC ±.05 3 PLC ±.005 4 PLC ±.0001 ANGLES ± FINISH		CUSTOMER DRAWING	SIZE A2	CAGE CODE 00779
MATERIAL -		DRAWING NO 1658871	RESTRICTED TO -	SCALE 4
			SHEET 1 OF 4	REV B

4

3

2

1

THIS DRAWING IS UNPUBLISHED. RELEASED FOR PUBLICATION 20
 © COPYRIGHT 20 BY TYCO ELECTRONICS CORPORATION. ALL RIGHTS RESERVED.

LOC	DIST	REVISIONS			
P	LTR	DESCRIPTION	DATE	DWN	APVD
ES	00	-	SEE SHEET 1	-	-

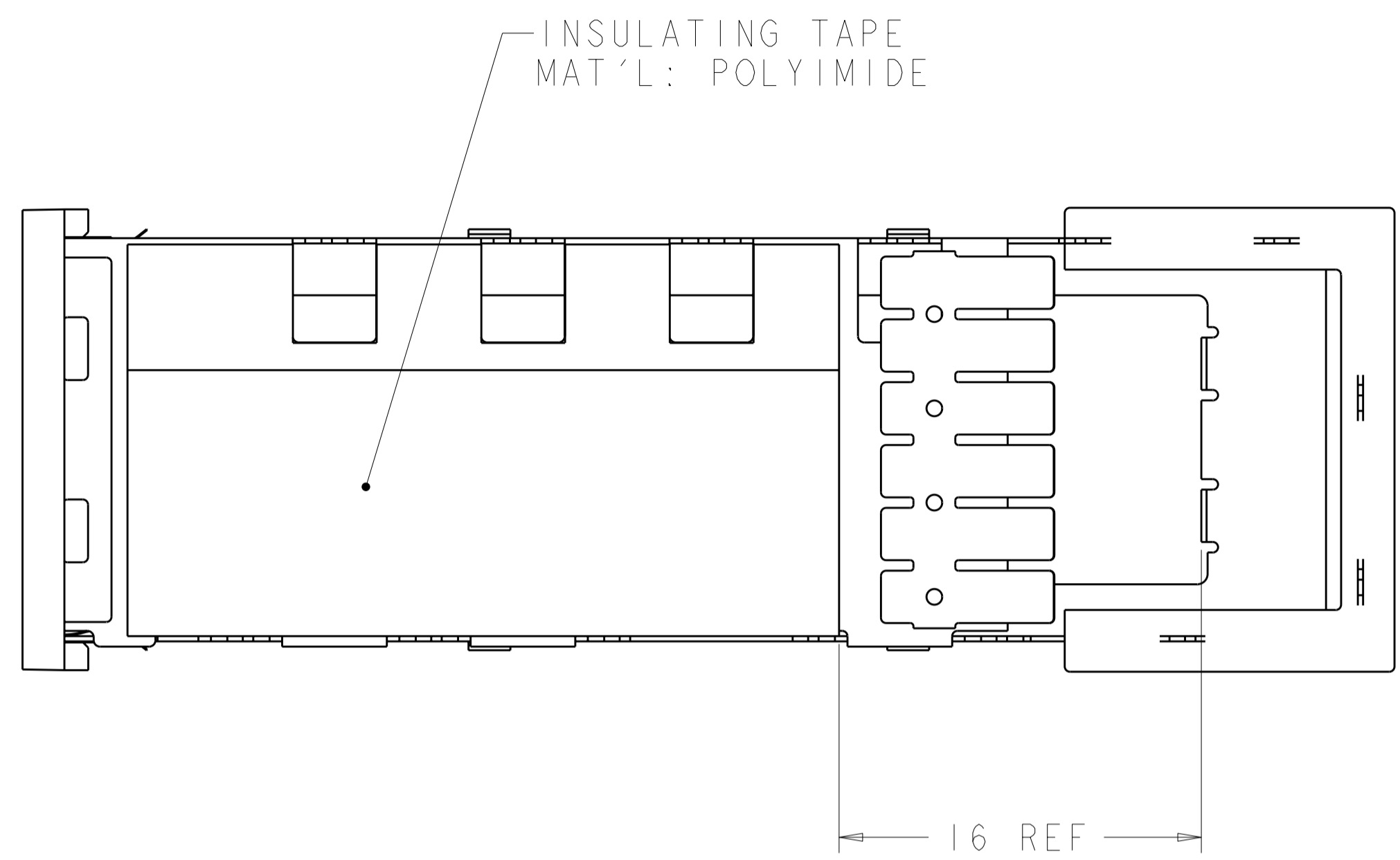

VIEW R - R

- ① MATES WITH XFP-MSA COMPLIANT TRANSCEIVERS.
- ② DATUM -X- AND -Y- ESTABLISHED BY CUSTOMER.
- ③ DATUM -A- IS TOP SURFACE OF HOST BOARD.
- ④ INDICATED SURFACES TO BE CONDUCTIVE AND CONNECTED TO CHASSIS GROUND.

<small>THIS DRAWING IS A CONTROLLED DOCUMENT FOR TYCO ELECTRONICS CORPORATION IT IS SUBJECT TO CHANGE AND THE CONTROLLING ENGINEERING ORGANIZATION SHOULD BE CONTACTED FOR THE LATEST REVISION.</small>		DWN D.E.STAHL 20NOV03 CHK E.BRIGHT 20NOV03 APVD E.BRIGHT 20NOV03	Tyco Electronics Shanghai, China
DIMENSIONS: mm 	TOLERANCES UNLESS OTHERWISE SPECIFIED: 0 PLC ±.1 1 PLC ±.1 2 PLC ±.05 3 PLC ±.005 4 PLC ±.0001 ANGLES ± FINISH	PRODUCT SPEC 108-2127 APPLICATION SPEC 114-13096 WEIGHT -	NAME ASSEMBLY, XFP CAGE WITH INSULATING TAPE SIZE CAGE CODE DRAWING NO RESTRICTED TO A2 00779 C-1658871 -
MATERIAL -		CUSTOMER DRAWING	
		SCALE 4	SHEET 2 OF 4 REV B

THIS DRAWING IS UNPUBLISHED. RELEASED FOR PUBLICATION 20
 © COPYRIGHT 20 BY TYCO ELECTRONICS CORPORATION. ALL RIGHTS RESERVED.

LOC	DIST	REVISIONS			
P	LTR	DESCRIPTION	DATE	DWN	APVD
ES	00	SEE SHEET 1			

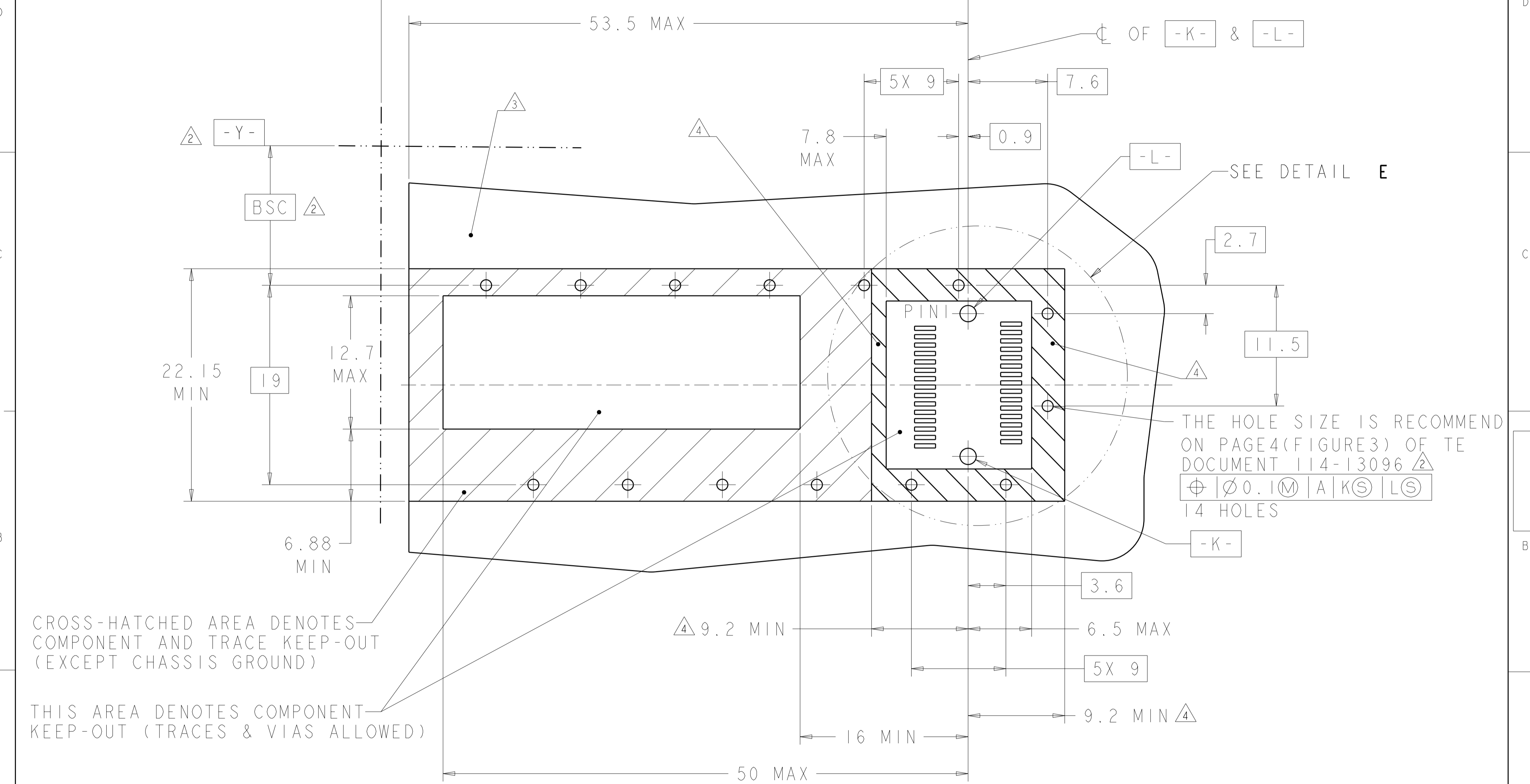

CROSS-HATCHED AREA DENOTES COMPONENT AND TRACE KEEP-OUT (EXCEPT CHASSIS GROUND)

THIS AREA DENOTES COMPONENT KEEP-OUT (TRACES & VIAS ALLOWED)

THE HOLE SIZE IS RECOMMEND ON PAGE 4 (FIGURE 3) OF TE DOCUMENT 114-13096
 Ø 0.1 (M) A (K) S (L) S
 14 HOLES

DETAILED HOST BOARD MECHANICAL LAYOUT

<small>THIS DRAWING IS A CONTROLLED DOCUMENT FOR TYCO ELECTRONICS CORPORATION. IT IS SUBJECT TO CHANGE AND THE CONTROLLING ENGINEERING ORGANIZATION SHOULD BE CONTACTED FOR THE LATEST REVISION.</small>		DWN D.E.STAHL 20NOV03 CHK E.BRIGHT 20NOV03 APVD E.BRIGHT 20NOV03	Tyco Electronics Tyco Electronics Shanghai, China
DIMENSIONS: mm 	TOLERANCES UNLESS OTHERWISE SPECIFIED: 0 PLC ± 1 PLC ±.1 2 PLC ±.05 3 PLC ±.005 4 PLC ±.0001 ANGLES FINISH	PRODUCT SPEC 108-2127 APPLICATION SPEC 114-13096 WEIGHT -	NAME ASSEMBLY, XFP CAGE WITH INSULATING TAPE SIZE A2 CAGE CODE 00779 DRAWING NO. 1658871 RESTRICTED TO -
MATERIAL -		CUSTOMER DRAWING	SCALE 4 SHEET 3 OF 4 REV B

THIS DRAWING IS UNPUBLISHED. RELEASED FOR PUBLICATION 20
 © COPYRIGHT 20 BY TYCO ELECTRONICS CORPORATION. ALL RIGHTS RESERVED.

LOC	DIST	REVISIONS			
P	LTR	DESCRIPTION	DATE	DWN	APVD
ES	00	SEE SHEET 1			

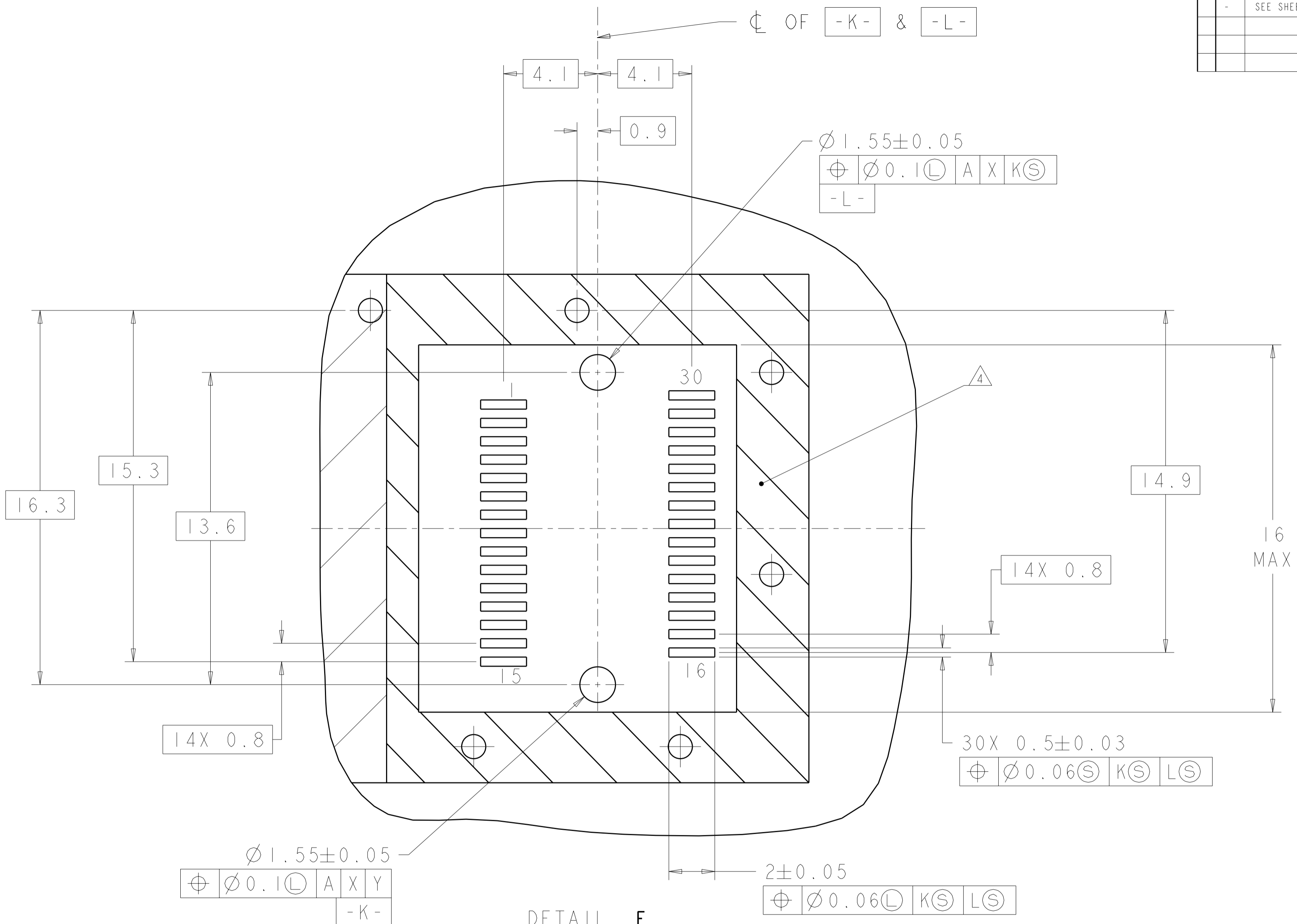

Ø1.55±0.05
 ⊕ Ø0.1(L) AX Y
 -K-

2±0.05
 ⊕ Ø0.06(L) K(S) L(S)

DETAIL E
 SCALE 8:1

DETAILED HOST BOARD MECHANICAL LAYOUT

THIS DRAWING IS A CONTROLLED DOCUMENT FOR TYCO ELECTRONICS CORPORATION. IT IS SUBJECT TO CHANGE AND THE CONTROLLING ENGINEERING ORGANIZATION SHOULD BE CONTACTED FOR THE LATEST REVISION.		DWN D.E.STAHL 20NOV03	Tyco Electronics Shanghai, China	
DIMENSIONS: mm		CHK E.BRIGHT 20NOV03	NAME ASSEMBLY, XFP CAGE WITH INSULATING TAPE	
TOLERANCES UNLESS OTHERWISE SPECIFIED: 0 PLC ±- 1 PLC ±.1 2 PLC ±.05 3 PLC ±.005 4 PLC ±.0001 ANGLES ±- FINISH		APVD E.BRIGHT 20NOV03	PRODUCT SPEC 108-2127	
MATERIAL		APPLICATION SPEC 114-13096	RESTRICTED TO	
		WEIGHT	SIZE CAGE CODE DRAWING NO A2 00779 C-1658871	
		CUSTOMER DRAWING	SCALE 4 SHEET 4 OF 4 REV B	