

NOTES:

1. MATERIAL: SEE TABLE
2. FINISHES: SEE TABLE
3. PRODUCT SPECIFICATION: NOT REQUIRED
4. PACKAGING: NOT REQUIRED
5. MATES WITH: NONE
6. INCH DIMS ARE SHOWN IN PARENTHESIS (XXX)
7. "XX" REFERS TO QTY. OF CIRCUITS

MATERIAL NUMBER (STD.)	MATERIAL NUMBER (-50)	NO. OF CIRCUITS	A	B
386312602	386313802	2	25.9 (1.02)	11.13 (.438)
386312603	386313803	3	37.1 (1.46)	22.22 (.875)
386312604	386313804	4	48.3 (1.90)	33.35 (1.313)
386312605	386313805	5	59.2 (2.33)	44.45 (1.750)
386312606	386313806	6	70.4 (2.77)	55.57 (2.188)
386312607	386313807	7	81.5 (3.21)	66.67 (2.625)
386312608	386313808	8	92.7 (3.65)	77.80 (3.063)
386312609	386313809	9	103.6 (4.08)	88.90 (3.500)
386312610	386313810	10	114.8 (4.52)	100.03 (3.938)
386312611	386313811	11	125.9 (4.96)	111.13 (4.375)
386312612	386313812	12	137.2 (5.40)	122.25 (4.813)
386312613	386313813	13	148.1 (5.83)	133.35 (5.250)
386312614	386313814	14	159.3 (6.27)	144.45 (5.687)
386312615	386313815	15	170.4 (6.71)	155.58 (6.125)
386312616	386313816	16	181.6 (7.15)	166.70 (6.563)

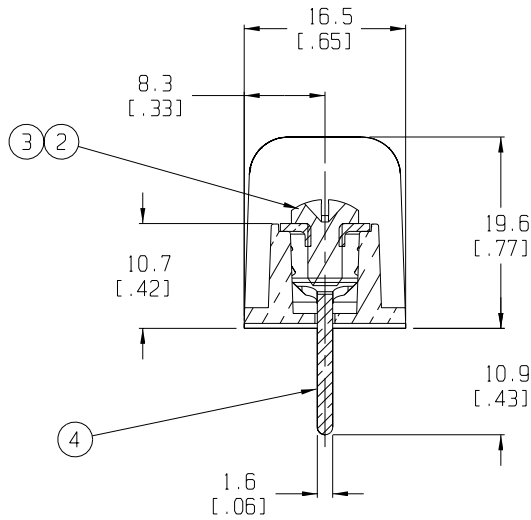
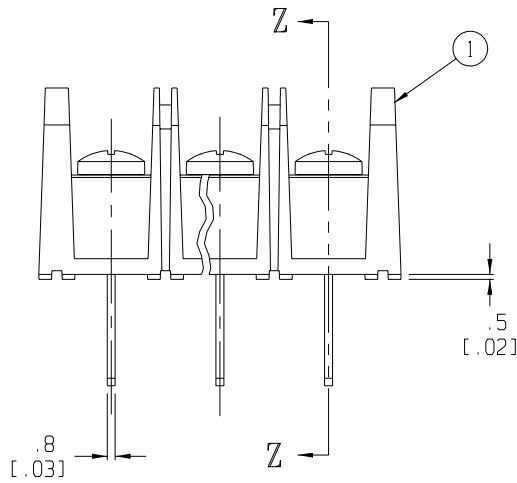

SECTION Z-Z

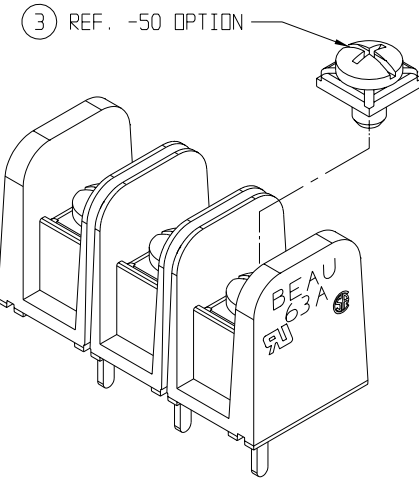

ITEM	QTY.	DESCRIPTION	MATERIAL	FINISH
4	XX	TERMINAL, WIRE WRAP, STD.	BRASS	TIN PLATE
3	XX	PAN HD. SCREW & WASHER, 6-32	BRASS	BRT.ZINC PLATE
2	XX	BINDING HD. SCREW, 6-32	STEEL	BRT.ZINC PLATE
1	1	BARRIER TERMINAL STRIP	PVC	BLACK

ECD 11339 RELEASE R. STONE	QUALITY SYMBOLS: MAJOR = CRITICAL = SPC = S =	GENERAL TOLERANCES: (UNLESS SPECIFIED)	SCALE	DESIGN UNITS	THIRD ANGLE PROJECTION	PROJECT NO. E-656	1	-	
			2:1	<input type="checkbox"/> mm <input checked="" type="checkbox"/> INCH		DIMENSIONS:	SHT	REV	
EC NO. DRWN: R. STONE CHK: CH K. APPR:	DESCRIPTION REV	4 PLACES ±.0015 3 PLACES ±.038 ±.005 2 PLACES ±.13 ±.01 1 PLACE ±.3	DRAWN BY & DATE R. STONE 3-26-03	TITLE: 63A SERIES BTS, 600V WIRE WRAP (STD.), NO MTG. ENDS	<input checked="" type="checkbox"/> mm <input type="checkbox"/> INCH	<input type="checkbox"/> mm <input type="checkbox"/> INCH	<input type="checkbox"/> mm ONLY	REVISE ON CAD ONLY	
		ANGULAR: ±2° DRAFT WHERE APPLICABLE MUST REMAIN WITHIN DIMENSIONS	CAD FILENAME 63A7XX-C-001	MATERIAL NO. SEE CHART	DRAWING NO. SD-38631-002	SHEET NO. 1 OF 1			
THIS DRAWING CONTAINS INFORMATION THAT IS PROPRIETARY TO MOLEX INCORPORATED AND SHOULD NOT BE USED WITHOUT WRITTEN PERMISSION.								SIZE	B