

AC	8.00	4.25
AB	7.25	4.25
AA	6.50	4.25
LETTER CODE	DIM Y	DIM Z

E	AA	AA	E				
D	AA	AA	D				
C	AB	AB	C				
B	AC	AC	B				
A	AB	AB	A				
ROW	1	2	3	4	5	6	ROW
POSITION							
CONTACT LOAD CHART							

- △ HOUSING MATERIAL: LIQUID CRYSTAL POLYMER.
COLOR: NATURAL.
- △ CONTACT MATERIAL: PHOSPHOR BRONZE
- △ CONTACT FINISH:(D)
UNDERPLATE (ENTIRE CONTACT):
0.00127 MIN NICKEL PER SAE-AMS-QQ-N-290
ON MATING SURFACES:
FLASH GOLD PER ASTM B 488, OVER
0.00076 MIN PALLADIUM-NICKEL OVER UNDERPLATE, OR
0.00076 MIN GOLD PER ASTM B 488 OVER UNDERPLATE.
ON LEADS:
0.00127 MIN MATTE TIN PER ASTM B 545 OVER UNDERPLATE.
LUBRICATION (MIN MATING SURFACES):
SURFACE CONDITIONER AFTER PLATING.
- △ PART MARKING LOCATED APPROXIMATELY AS SHOWN.

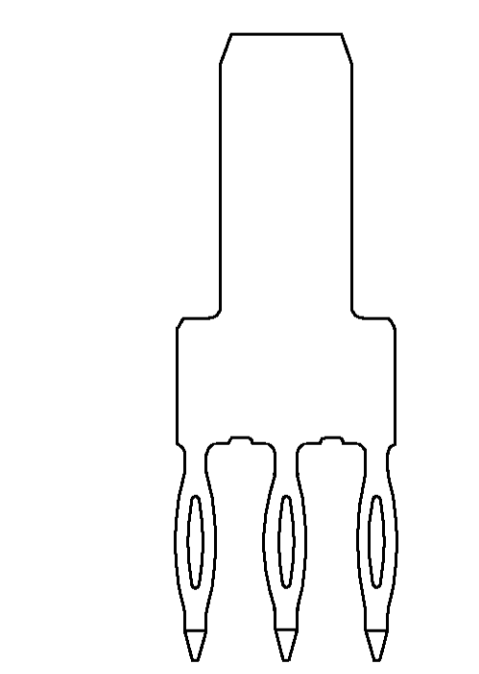
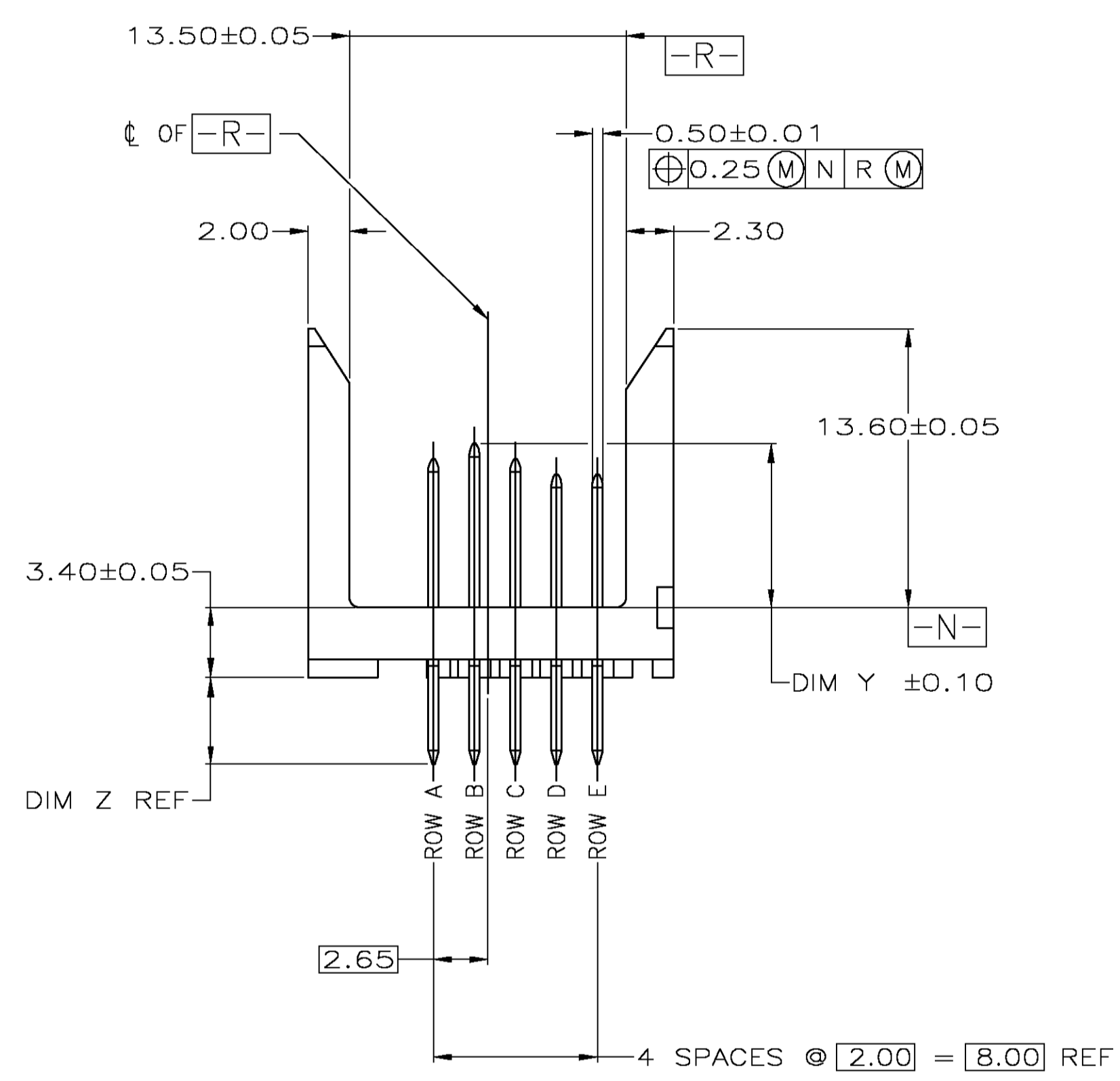

SECTION A-A
SCALE 6:1

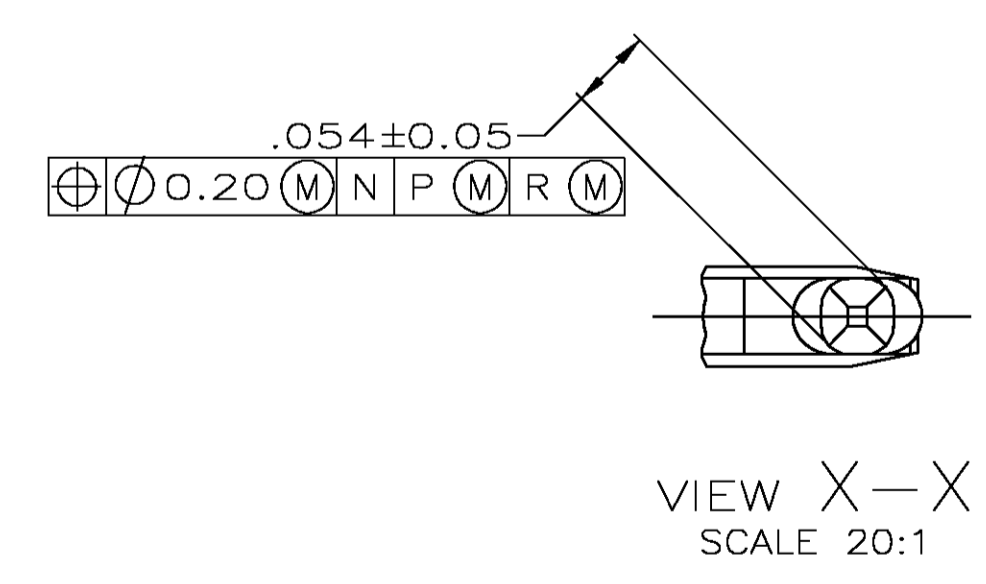

VIEW X-X
SCALE 20:1

3	5536684-1
FINISH	PART NUMBER

THIS DRAWING IS A CONTROLLED DOCUMENT.

DIMENSIONS:	TOLERANCES UNLESS OTHERWISE SPECIFIED:	DIN	T. SHUEY	7-21-98	Tyco Electronics Corporation Harrisburg, Pa 17105-3508
mm	0 PLC ± - 1 PLC ± - 2 PLC ± 0.13 3 PLC ± - 4 PLC ± - ANGLES ± -	CHK	D. KOVALICK	7-29-98	
MATERIAL	FINISH	APVD	D. KOVALICK	7-29-98	NAME
1	3	PRODUCT SPEC			PIN ASSY, POWER, VERTICAL, Z-PACK 2mm FB, 5 ROW, PRESS FIT LEADS, FULLY LOADED
		APPLICATION SPEC			SIZE
		WEIGHT			A1
		CUSTOMER DRAWING			00779
		SCALE	4:1	SHEET	1 OF 1
		REV			0