

NHD-C0220AA-FSW-FTW

Graphic Liquid Crystal Display Module

NHD- Newhaven Display
C0220- COG, 2 Lines x 20 Characters
AA- Model
F- Transflective
SW- Side White LED Backlight
F- FSTN Positive
T- 12:00 Optimum View
W- Wide Temp
RoHS Compliant

Newhaven Display International, Inc.

2661 Galvin Ct.

Elgin IL, 60124

Ph: 847-844-8795

Fax: 847-844-8796

www.newhavendisplay.com

nhtech@newhavendisplay.com

nhsales@newhavendisplay.com

Document Revision History

Revision	Date	Description	Changed by
0	11/5/10	Initial Release	-
1	5/27/11	Display character address code updated	AK
2	6/2/11	Timing characteristics updated	AK
3	9/28/15	Electrical characteristics, response times updated	SB
4	12/28/17	Backlight Characteristics Updated	SB
5	2/19/19	Backlight Current Updated	SB
6	7/5/19	Added PCB Footprint Drawing	AS
7	11/26/19	Electrical Characteristics Updated	SB

Functions and Features

- 2 lines x 20 characters
- Built-in NT7605 controller
- 3.3V power supply
- 1/16 duty, 1/5 bias

SYMBOL	REVISION	DATE

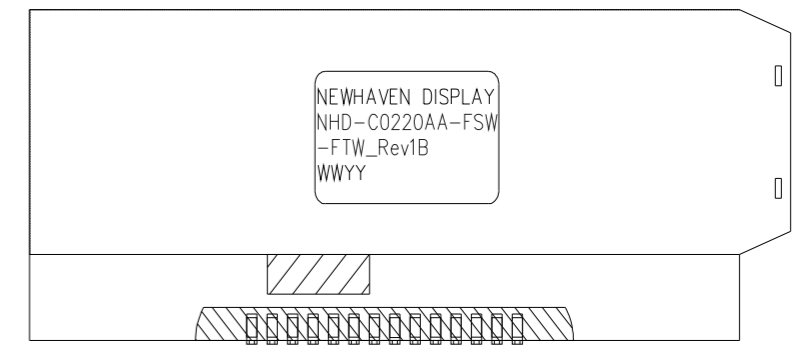
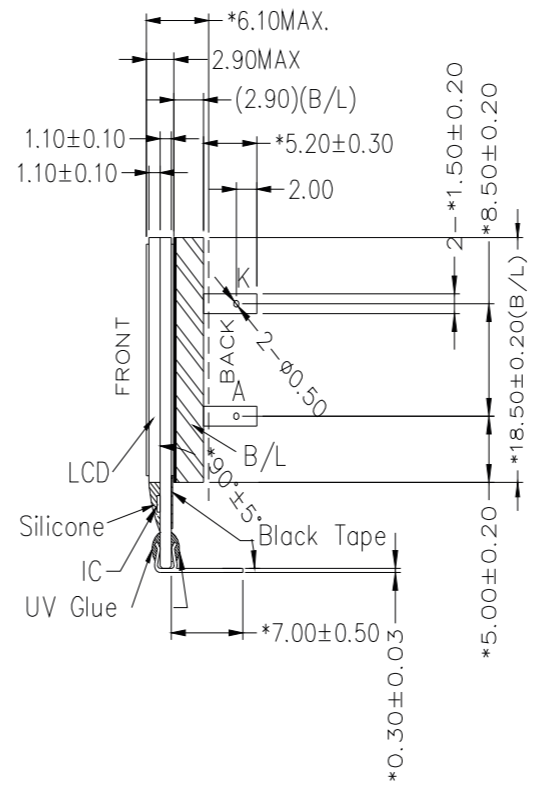
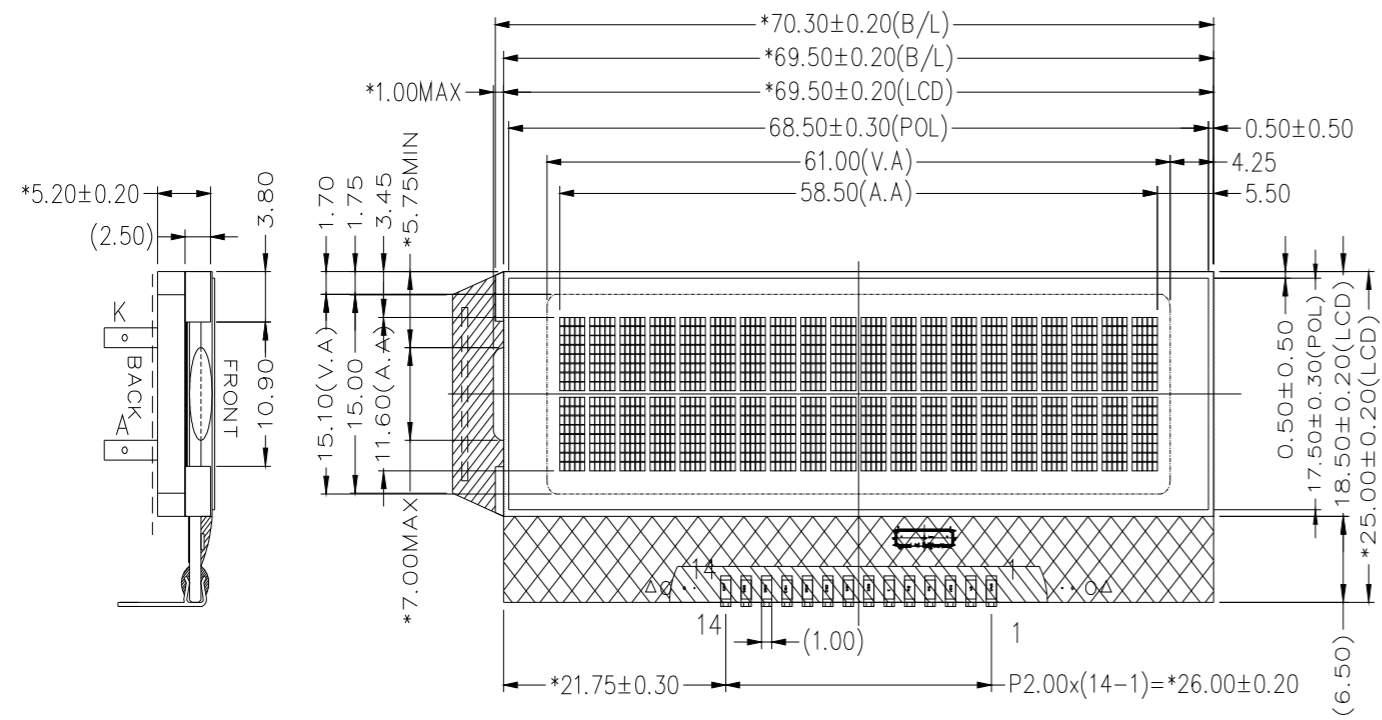

BACK VIEW

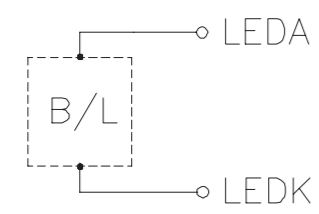
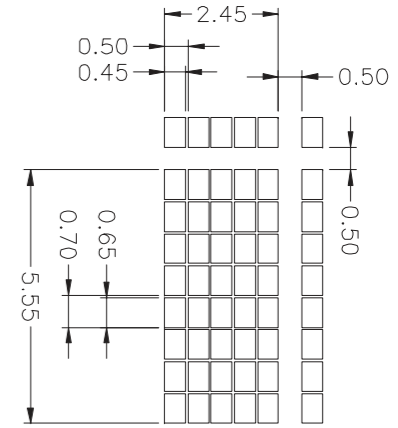
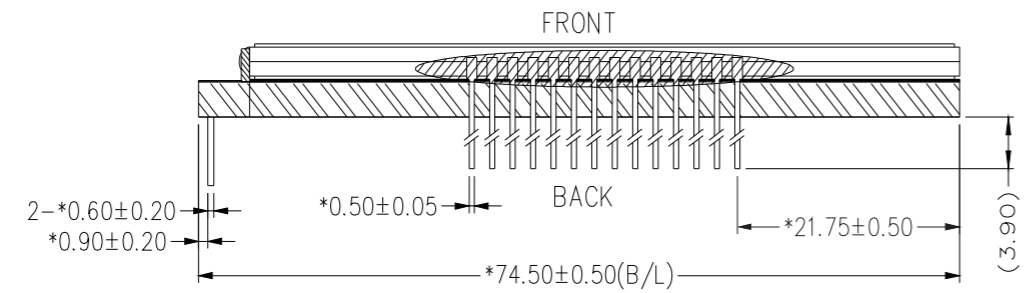

CONSTANT CURRENT:30mA,3.00±0.20V
BACKLIGHT DRIVER CIRCUIT DIAGRAM

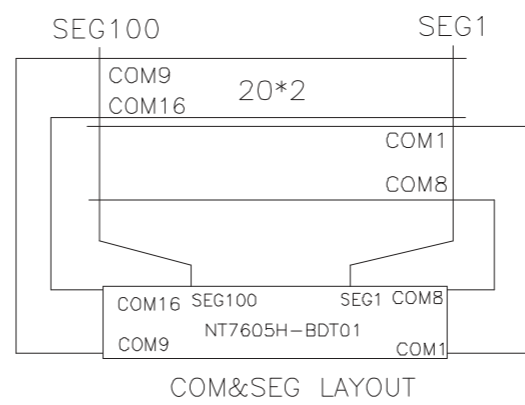

Pin Assignments

PIN	1	2	3	4	5	6	7
CONNECTION	GND	V5	VDD	RS	R/W	E	DB0
PIN	8	9	10	11	12	13	14
CONNECTION	DB1	DB2	DB3	DB4	DB5	DB6	DB7

ITEM	PARAMETERS	ITEM	PARAMETERS
DISPLAY TYPE	FSTN, POSITIVE	VIEWING DIRECTION	12 O'CLOCK
DRIVING METHOD	1/16 DUTY, 1/5 BIAS	OPERATING TEMPERATURE	-20°C TO +70°C
POLARIZER TYPE	TRANSFLECTIVE	STORAGE TEMPERATURE	-30°C TO +80°C
LCD OPERATING VOLTAGE	3.2V(REF)	IC	NT7605H-BDT01
LOGIC VOLTAGE(VDD)	3.3V	BACKLIGHT	EDGE, WHITE(2 LEDS)

STANDARD TOLERANCE:
(UNLESS OTHERWISE SPECIFIED)

LINEAR: ±0.3mm

UNLESS OTHERWISE SPECIFIED:
- DIMENSIONS ARE IN MILLIMETERS
- THIRD ANGLE PROJECTION

DO NOT SCALE DRAWING

NEWHAVEN DISPLAY INTERNATIONAL

DRAWING/PART NUMBER:
NHD-C0220AA-FSW-FTW

REVISION:
1B

SIZE:
A3

SCALE:
NS

SHEET 1 OF 1



THIS DRAWING IS SOLELY THE PROPERTY OF NEWHAVEN DISPLAY INTERNATIONAL, INC. THE INFORMATION IT CONTAINS IS NOT TO BE DISCLOSED, REPRODUCED OR COPIED IN WHOLE OR PART WITHOUT WRITTEN APPROVAL FROM NEWHAVEN DISPLAY.

Recommended PCB Footprint

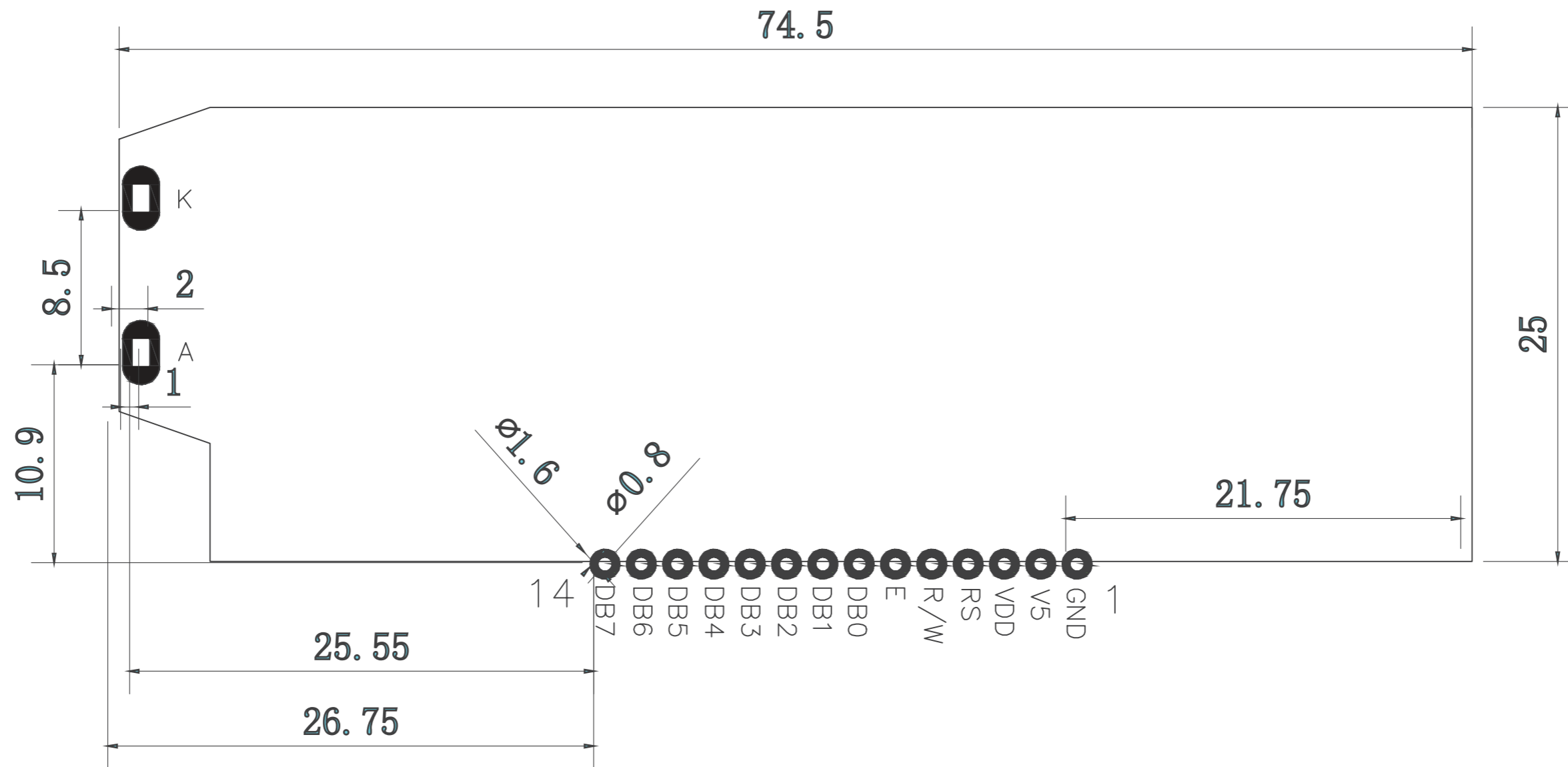
SYMBOL	REVISION	DATE



Applicable Displays:
 1) NHD-C0220AA-FSW-FTW
 2) NHD-C0220AZ-FSW-FTW

STANDARD TOLERANCE: (UNLESS OTHERWISE SPECIFIED)			
LINEAR: ±0.3mm		DRAWING/PART NUMBER: NHD-C0220(AZ&AA) Footprint	
UNLESS OTHERWISE SPECIFIED: - DIMENSIONS ARE IN MILLIMETERS - THIRD ANGLE PROJECTION 		DRAWN BY: A. Shah	APPROVED BY: A. Khan
		DRAWN DATE: 7/1/19	APPROVED DATE: 7/1/19
		DO NOT SCALE DRAWING	
		SHEET 1 OF 1	
THIS DRAWING IS SOLELY THE PROPERTY OF NEWHAVEN DISPLAY INTERNATIONAL, INC. THE INFORMATION IT CONTAINS IS NOT TO BE DISCLOSED, REPRODUCED OR COPIED IN WHOLE OR PART WITHOUT WRITTEN APPROVAL FROM NEWHAVEN DISPLAY.			

Pin Description and Wiring Diagram

Pin No.	Symbol	External Connection	Function Description
1	GND	Power Supply	Ground
2	V _s	Adj. Power Supply	Supply Voltage for Contrast (approx. 0.1V)
3	V _{DD}	Power Supply	Supply Voltage for LCD and Logic
4	RS	MPU	Register Select: 0=Instruction, 1=Data
5	R/W	MPU	Read / Write select: 0=Write, 1=Read
6	E	MPU	Operation Enable Signal.
7-10	DB0 – DB3	MPU	Four low order bi-directional three-state data bus lines. These four are not used during 4-bit operation.
11-14	DB4 – DB7	MPU	Four high order bi-directional three-state data bus lines.
A	LED +	Power Supply	Backlight Anode (30 mA @ 3V)
K	LED -	Power Supply	Backlight Cathode (Ground)

Recommended LCD connector: 2.0mm pitch, 14pins Soldered to PCB, or JST p/n: PHR-14

Backlight connector: A and K pins **Mates with:** Solder to wires or PCB

Recommended Breakout Board: [NHD-PCB40](#)

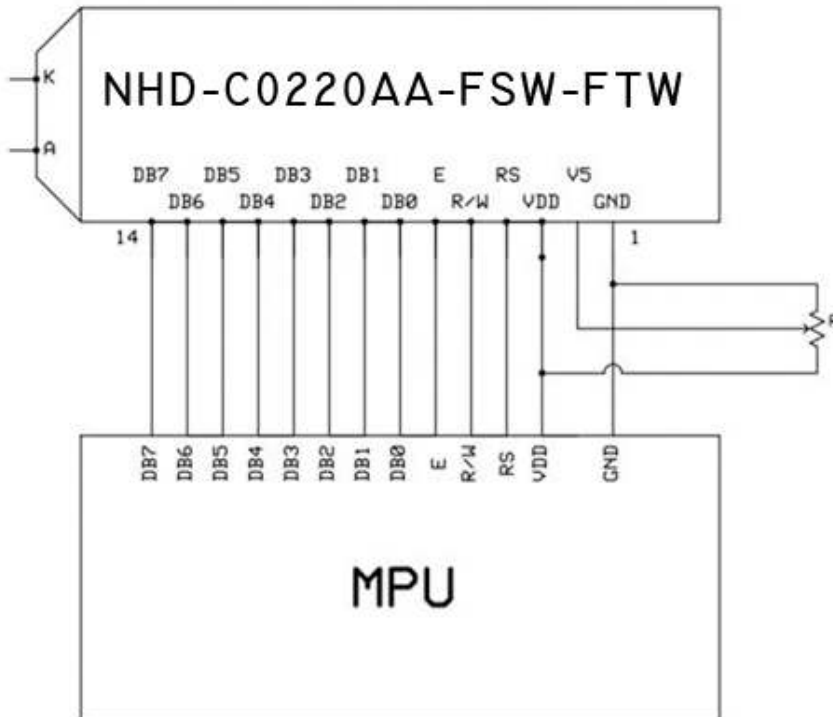

Electrical Characteristics

Item	Symbol	Condition	Min.	Typ.	Max.	Unit
Operating Temperature Range	T _{OP}	Absolute Max	-20	25	+70	°C
Storage Temperature Range	T _{ST}	Absolute Max	-30	25	+80	°C
Supply Voltage	V _{DD}	-	3.0	3.3	3.5	V
Supply Current	I _{DD}	V _{DD} = 3.3V	0.3	0.6	2	mA
Supply for LCD (contrast)	V _{DD} - V ₅	T _{OP} = 25°C	3.0	3.2	3.5	V
"H" Level input	V _{IH}	-	0.8 * V _{DD}	-	V _{DD}	V
"L" Level input	V _{IL}	-	0	-	0.2 * V _{DD}	V
"H" Level output	V _{OH}	-	V _{DD} - 0.6	-	V _{DD}	V
"L" Level output	V _{OL}	-	GND	-	GND + 0.6	V
Backlight Supply Current	V _{LED}	-	-	30	36	mA
Backlight Supply Voltage	I _{LED}	I _{LED} = 30 mA	2.8	3.0	3.3	V

*The LED of the backlight is driven by current; drive voltage is for reference only. Drive voltage must be selected to ensure backlight current drain is below MAX level stated.

Optical Characteristics

Item	Symbol	Condition	Min.	Typ.	Max.	Unit
Optimal Viewing Angles	Top	CR ≥ 2	-	40	-	°
	Bottom		-	40	-	°
	Left		-	35	-	°
	Right		-	35	-	°
Contrast Ratio	CR	-	-	6	-	-
Response Time (rise)	T _R	-	-	100	160	ms
Response Time (fall)	T _F	-	-	150	200	ms

Controller Information

Built-in NT7605H-BDT01 Controller.

Please download specification at http://www.newhavendisplay.com/app_notes/NT7605.pdf

NOTE: The Busy Flag of the NT7605 controller may not always be responsive. Add sufficient delays and/or a time-out check routine to continue operation if busy flag is not cleared.

Note: during internal operation, busy flag (DB7) is read "High".
 Busy flag check must be preceded by the next instruction.

DDRAM Address

1	2	3	4	5	6	7	8	9	10	11	12	13	14	15	16	17	18	19	20
00	01	02	03	04	05	06	07	08	09	0A	0B	0C	0D	0E	0F	10	11	12	13
40	41	42	43	44	45	46	47	48	49	4A	4B	4C	4D	4E	4F	50	51	52	53

Table of Commands

Instruction	INSTRUCTION CODE										Description	Execution Time (Max) (fosc = 540KHZ)	
	RS	R/W	DB7	DB6	DB5	DB4	DB3	DB2	DB1	DB0			
Clear Display	0	0	0	0	0	0	0	0	0	0	1	Clear entire display area. Restore display from shift, and load address counter with DDRAM address 00H	1.64ms
Display/ Cursor Home	0	0	0	0	0	0	0	0	0	1	-	Restore display from shift and load address counter with DDRAM address 00H	1.64ms
Entry mode Set	0	0	0	0	0	0	0	0	1	I/D	S	Specify direction of cursor movement and display shift mode. This operation takes place after each data transfer (read/write)	40µs
Display ON/ OFF control	0	0	0	0	0	0	0	1	D	C	B	Set activation of display (D), cursor (C), and Blinking of cursor (B)	40µs
Display/ Cursor	0	0	0	0	0	0	1	S/C	R/L	-	-	Shift display or move cursor	40µs
Function set	0	0	0	0	1	DL	N	F	-	-	-	Set interface data length (DL) number of the display line (N), and character font (F)	40µs
RAM Address Set	0	0	0	1	ACG						Set CGRAM address in address counter.	40µs	
DDRAM Address Set	0	0	1	ADD						Set DDRAM address in address counter.	40µs		
Busy Flag/ Address Counter Read	0	1	BF	AC						Read Busy Flag (BF) and contents of Address Counter (AC)	1µs		
CGRAM/ DDRAM Data Write	1	0	Write Data						Write data into internal RAM (DDRAM/CGRAM).	40µs			
CGRAM/ DDRAM Data Read	1	1	Read Data						Read data from internal RAM (DDRAM/CGRAM).	40µs			
	I/D = 1 : Increment I/D = 0 : Decrement S = 1 : Display Shift On D = 1 : Display On C = 1 : Cursor Display On B = 1 : Cursor Blink On S/C = 1 : Shift Display S/C = 0 : Move Cursor R/L = 1 : Shift Right R/L = 0 : Shift Left DL = 1 : 8-Bit DL = 0 : 4-Bit N = 1 : Dual Line N = 0 : Single Line F = 1 : 5x10 dots F = 0 : 5x8 dots BF = 1 : Internal Operation BF = 0 : Ready for Instruction										DDRAM : Display Data Ram CGRAM : Character Generator RAM ACG : Character Generator RAM Address ADD : Display Data RAM Address AC : Address Counter		

Timing Characteristics

Write from MPU to NT7605

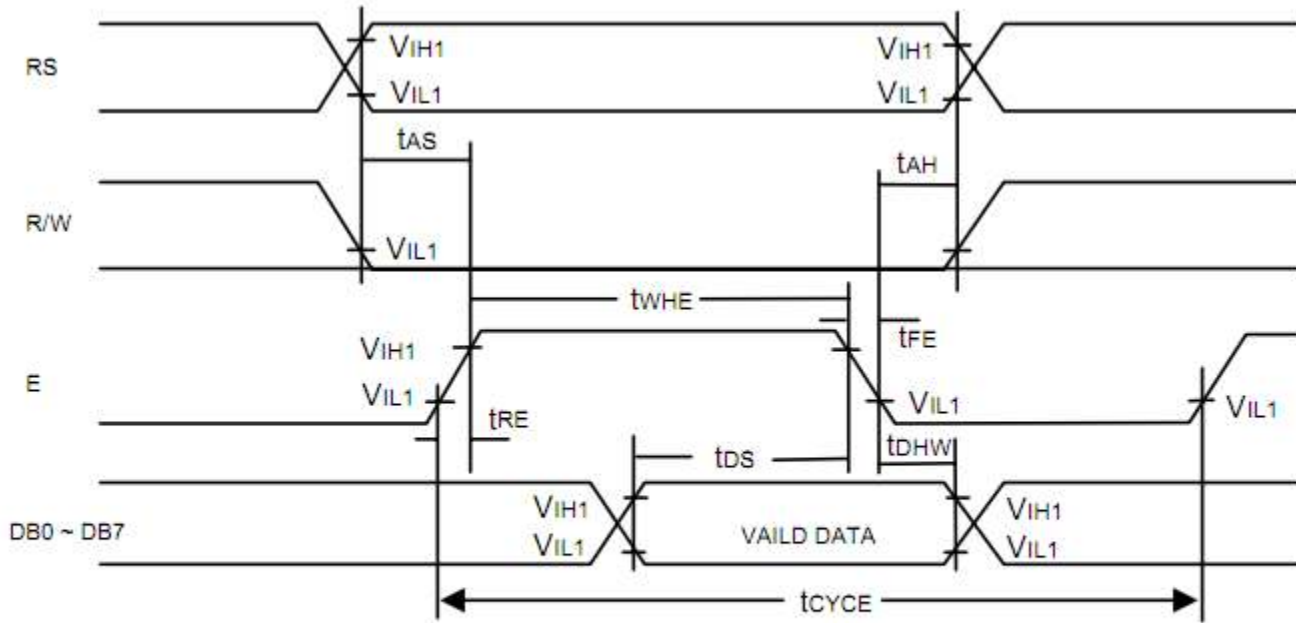

Figure 2. Bus Write Operation Sequence
(Writing data from MPU to NT7605)

Write Cycle ($V_{DD} = 4.5V \sim 5.5V$, $GND = 0V$, $T_A = 25^\circ C$)

Symbol	Parameter	Min.	Typ.	Max.	Unit	Conditions
tCYCE	Enable Cycle Time	500	-	-	ns	Figure 2
twHE	Enable "H" Level Pulse Width	300	-	-	ns	Figure 2
tRE, tFE	Enable Rise/Fall Time	-	-	25	ns	Figure 2
tAS	RS, R/W Setup Time	60 ¹	-	-	ns	Figure 2
		100 ²				
tAH	RS, R/W Address Hold Time	10	-	-	ns	Figure 2
tDS	Data Output Delay	100	-	-	ns	Figure 2
tDHW	Data Hold Time	10	-	-	ns	Figure 2

Notes: 1: 8-bit operation mode
2: 4-bit operation mode

Read from NT7605 to MPU

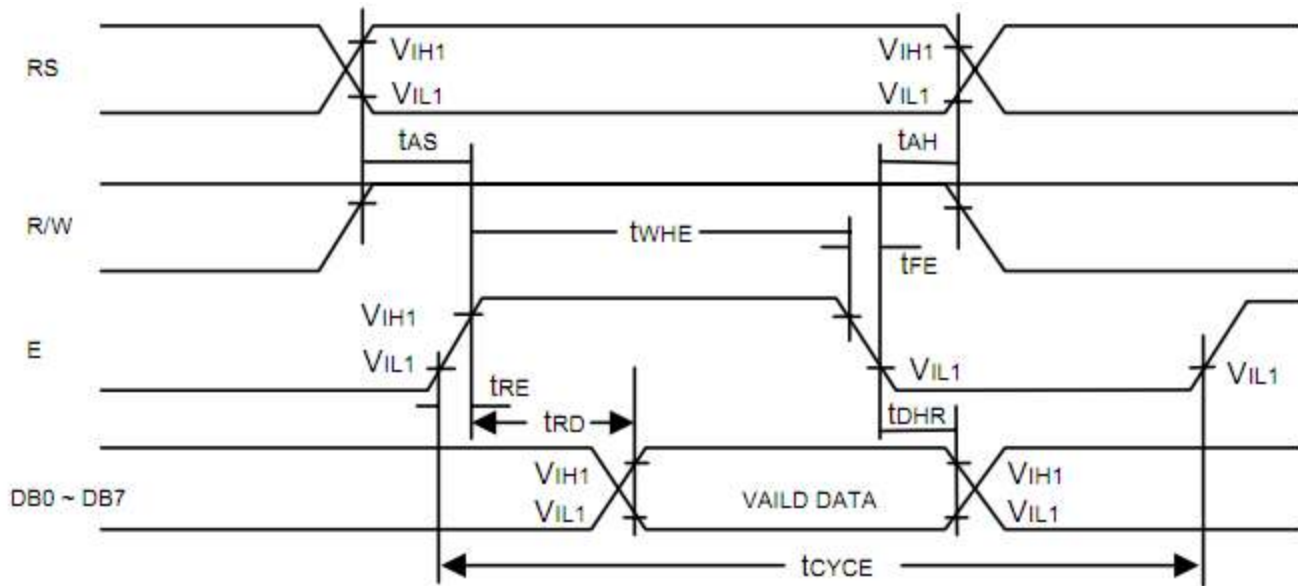

Figure 1. Bus Read Operation Sequence
(Reading out data from NT7605 to MPU)

Read Cycle ($V_{DD} = 4.5V \sim 5.5V$, $GND = 0V$, $T_A = 25^\circ C$)

Symbol	Parameter	Min.	Typ.	Max.	Unit	Conditions
tCYCE	Enable Cycle Time	500	-	-	ns	Figure 1
tWHE	Enable "H" Level Pulse Width	300	-	-	ns	Figure 1
tRE, tFE	Enable Rise/Fall Time	-	-	25	ns	Figure 1
tAS	RS, R/W Setup Time	60 ¹	-	-	ns	Figure 1
		100 ²				
tAH	RS, R/W Address Hold Time	10	-	-	ns	Figure 1
tRD	Read Data Output Delay	-	-	190	ns	Figure 1
tDHR	Read Data Hold Time	20	-	-	ns	Figure 1

Notes: 1: 8-bit operation mode
2: 4-bit operation mode

Built-in Font Table

		Higher 4-bit (D4 to D7) of Character Code (Hexadecimal)															
		0	1	2	3	4	5	6	7	8	9	A	B	C	D	E	F
Lower 4-bit (D0 to D3) of Character Code (Hexadecimal)	0	CG RAM (1)			G	O	P	^	P				—	3	E	o	p
	1	CG RAM (2)		!	1	A	O	a	a				#	7	*	4	a
	2	CG RAM (3)		"	2	B	R	b	r				"	4	v	x	p
	3	CG RAM (4)		*	3	O	S	s	s				!	o	t	e	e
	4	CG RAM (5)		*	4	O	T	t	t				\	o	t	t	o
	5	CG RAM (6)		%	5	E	U	u	u				.	*	*	u	u
	6	CG RAM (7)		%	6	F	V	v	v				o	o	c	e	p
	7	CG RAM (8)		7	W	w	w	w				7	*	*	7	g	w
	8	CG RAM (1)		8	X	x	x	x				4	o	*	u	u	x
	9	CG RAM (2)		9	Y	y	y	y				o	o	u	u	u	y
	A	CG RAM (3)		*	U	Z	z	z				o	o	v	v	u	z
	B	CG RAM (4)		+	K	X	x	x				*	*	e	e	o	x
	C	CG RAM (5)		.	<	*	U	U				*	o	o	o	o	o
	D	CG RAM (6)		—	—	M	N	N				u	x	x	c	t	.
	E	CG RAM (7)		#	>	N	N	N				#	e	e	e	o	o
	F	CG RAM (8)		/	?	O	L	o				u	v	v	o	o	

Example Initialization Program

```
'INIT-----  
A = &H30  
Call Writecom                                'wake up  
Waitms 100  
Call Writecom                                'wake up  
Waitms 10  
Call Writecom                                'wake up  
Waitms 10  
A = &H38  
'function set  
Call Writecom  
A = &H10  
'shift display=no  
Call Writecom  
A = &H0C  
'display on  
Call Writecom  
A = &H06  
'entry mode set  
Call Writecom  
'-----  
Sub Writecom  
P1 = A  
Reset P3.0  
'instruction  
Reset P3.7  
'RW  
Waitms 1  
Set P3.4  
'E  
Waitms 1  
Reset P3.4                                'E  
End Sub  
'-----  
Sub Writedata  
P1 = A  
Set P3.0  
'data  
Reset P3.7  
'RW  
Waitms 1  
Set P3.4  
'E  
Waitms 1  
Reset P3.4                                'E  
End Sub  
'-----
```

Quality Information

Test Item	Content of Test	Test Condition	Note
High Temperature storage	Endurance test applying the high storage temperature for a long time.	+80°C , 120 Hrs.	2
Low Temperature storage	Endurance test applying the low storage temperature for a long time.	-30°C , 120 Hrs.	1,2
High Temperature Operation	Endurance test applying the electric stress (voltage & current) and the high thermal stress for a long time.	+70°C , 120 Hrs.	2
Low Temperature Operation	Endurance test applying the electric stress (voltage & current) and the low thermal stress for a long time.	-20°C , 120 Hrs.	1,2
High Temperature / Humidity Operation	Endurance test applying the electric stress (voltage & current) and the high thermal with high humidity stress for a long time.	+40°C , 90% RH , 120 Hrs.	1,2
Thermal Shock resistance	Endurance test applying the electric stress (voltage & current) during a cycle of low and high thermal stress.	-20°C,30min -> 25°C,5min -> 70°C,30min = 1 cycle 10 cycles	
Vibration test	Endurance test applying vibration to simulate transportation and use.	10-55Hz , 15mm amplitude. 60 sec in each of 3 directions X,Y,Z For 15 minutes	3
Static electricity test	Endurance test applying electric static discharge.	Air Discharge= ±8kV, Contact Discharge = ±4kV Five Times	

Note 1: No condensation to be observed.

Note 2: Conducted after 4 hours of storage at 25°C, 0%RH.

Note 3: Test performed on product itself, not inside a container.

Precautions for using LCDs/LCMs

See Precautions at www.newhavendisplay.com/specs/precautions.pdf

Warranty Information and Terms & Conditions

http://www.newhavendisplay.com/index.php?main_page=terms