

Brief Description

The ZIOL2411 is a line driver/level shifter IC that provides two independent HV* I/O channels with a wide range of configurable system features. It addresses the physical layer of sensor/actuator systems in factory automation applications and is specifically designed to support the communication standard IO-Link[†].

The output drivers are push-pull stages, which in tandem mode reach an R_{DSon} of less than 3.3Ω at all operational temperatures.

The configuration is stored in an on-chip EEPROM and automatically loaded into the ZIOL2411's control register during power up. The ZIOL2411 also provides status information, such as overload and over-temperature conditions. An integrated SPI interface supports access to configuration and status registers.

The ZIOL2411 is fabricated in a powerful CMOS mixed signal technology that allows supply voltages up to 40V. The EEPROM read/write functionality is guaranteed within the entire operating temperature range in combination with a low-voltage core supply of 3.3V.

Features

- Configurable output current limits 56mA to 410mA per channel
- Standard cable driver/ physical layer transceiver for IO-Link (master and device)
- Slew-rate controlled drivers
- Wide range for configurable feature set, which is automatically loaded after power-on reset
- IO-Link-specific WURQ[‡] detection
- On chip registers and EEPROM for system configuration and status information
- SPI interface for accessing on-chip registers and EEPROM
- Digital interface: 3.3V output, 5V tolerant inputs
- IC temperature monitoring/diagnosis
- Over-current and over-temperature indication

Benefits

- Configurable feature set
- Nonvolatile storage of system configuration
- Excellent electromagnetic compatibility (EMC) performance due to adjustable output slew rate control
- Low R_{DSon} of 3.3Ω in tandem mode
- Programmable limitation of driver output current
- EEPROM read/write functionality within entire operating temperature range
- Space saving 4x4 mm² 24-pin QFN

Available Support

- Evaluation Kits
- Application Notes

Physical Characteristics

- Operation temperature: -40 to +85 °C
- Supply voltage 8.0 to 36.0 V
- RoHS-compliant QFN-24 package

ZIOL2411 Application Circuits

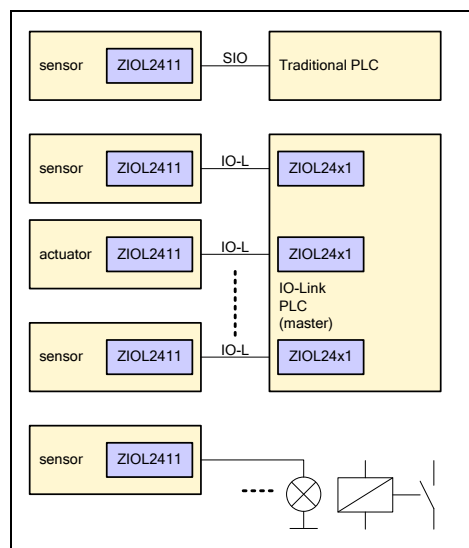

* High voltage (maximum power supply / signal swing is 36 volt)

† IDT is a member of the IO-Link Consortium: www.io-link.com

‡ IO-Link device wake-up

Typical Applications

In field applications, the ZIOL2411 acts as a universal cable driver. The ZIOL2411 can support IO-Link communications as a physical-layer transceiver (PHY) for IO-Link devices and IO-Link masters.

Common applications:

- 24V line driver/level shifter
- IO-Link-compliant devices
- IO-Link-compliant masters

See the ZIOL2xxx IC Family Data Sheet for detailed technical information.

ZIOL2411 Overview

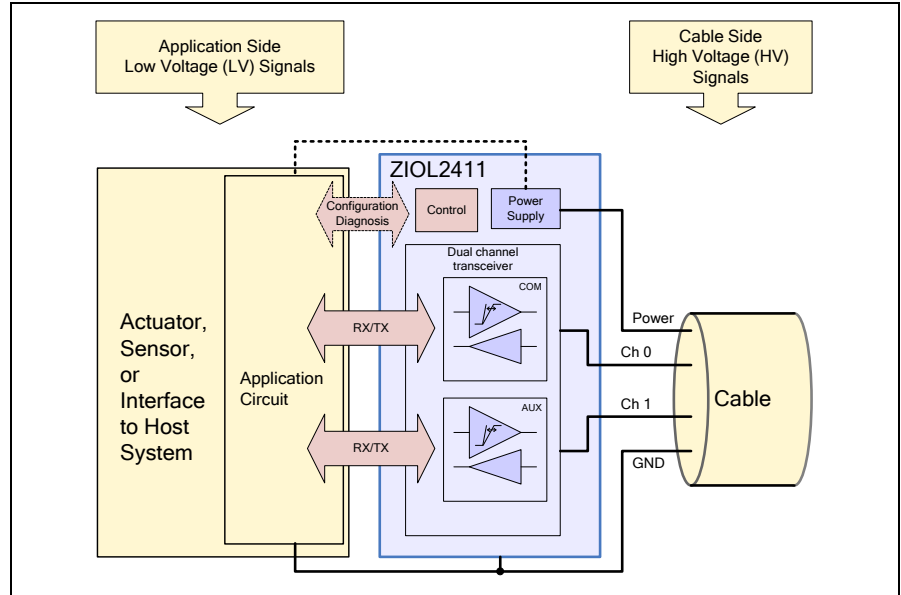

Ordering Information

Product Sales Code	Description	Package
ZIOL2411BI1R	Dual Channel IO-Link compliant HV Line Driver, 4x4mm QFN24	13" reel
ZIOL2411BI1W	Dual Channel IO-Link compliant HV Line Driver, 4x4mm QFN24	7" reel
IO-Link Lab Kit V2.0 #3600100858	ZIOL2401 Lab Kit for detailed laboratory evaluation: configurable IC/Communication/Controller Board, USB cable; software is available for download at www.IDT.com with a free customer login (see data sheet for details).	
ZIOL2401 Starter-Kit #3600100369	ZIOL2401 Starter Kit for product demonstration: USB stick, extension board, downloadable software	

Revision	Date	Description
2.20	August 12, 2015	Updates for order codes. Update for template and contact information. Update for information about software download. Minor edits for clarity.
	January 28, 2016	Changed to IDT branding.

IMPORTANT NOTICE AND DISCLAIMER

RENESAS ELECTRONICS CORPORATION AND ITS SUBSIDIARIES (“RENESAS”) PROVIDES TECHNICAL SPECIFICATIONS AND RELIABILITY DATA (INCLUDING DATASHEETS), DESIGN RESOURCES (INCLUDING REFERENCE DESIGNS), APPLICATION OR OTHER DESIGN ADVICE, WEB TOOLS, SAFETY INFORMATION, AND OTHER RESOURCES “AS IS” AND WITH ALL FAULTS, AND DISCLAIMS ALL WARRANTIES, EXPRESS OR IMPLIED, INCLUDING, WITHOUT LIMITATION, ANY IMPLIED WARRANTIES OF MERCHANTABILITY, FITNESS FOR A PARTICULAR PURPOSE, OR NON-INFRINGEMENT OF THIRD PARTY INTELLECTUAL PROPERTY RIGHTS.

These resources are intended for developers skilled in the art designing with Renesas products. You are solely responsible for (1) selecting the appropriate products for your application, (2) designing, validating, and testing your application, and (3) ensuring your application meets applicable standards, and any other safety, security, or other requirements. These resources are subject to change without notice. Renesas grants you permission to use these resources only for development of an application that uses Renesas products. Other reproduction or use of these resources is strictly prohibited. No license is granted to any other Renesas intellectual property or to any third party intellectual property. Renesas disclaims responsibility for, and you will fully indemnify Renesas and its representatives against, any claims, damages, costs, losses, or liabilities arising out of your use of these resources. Renesas' products are provided only subject to Renesas' Terms and Conditions of Sale or other applicable terms agreed to in writing. No use of any Renesas resources expands or otherwise alters any applicable warranties or warranty disclaimers for these products.

(Disclaimer Rev.1.0 Mar 2020)

Corporate Headquarters

TOYOSU FORESIA, 3-2-24 Toyosu,
Koto-ku, Tokyo 135-0061, Japan
www.renesas.com

Contact Information

For further information on a product, technology, the most up-to-date version of a document, or your nearest sales office, please visit:
www.renesas.com/contact/

Trademarks

Renesas and the Renesas logo are trademarks of Renesas Electronics Corporation. All trademarks and registered trademarks are the property of their respective owners.