Three-Channel CCM/DCM Boost LED Driver with Sub-Microsecond PWM Dimming

Features

- Three out-of-phase constant-current boost converters
- Current loop closed, with sub-microsecond PWM-dimming pulses, supports PWM dimming >20 kHz
- Internal 40V linear regulator
- External clock input
- External individual reference inputs
- Individual PWM dimming inputs
- Programmable slope compensation
- +0.2A/-0.4A gate drivers
- Independent short circuit protection with hiccup for each channel
- Latching output open-circuit protection

Applications

- LCD panel back-lighting

Description

HV9989 is a three-channel peak current mode PWM controller designed to drive single switch converters in a constant-output current mode. It can be used for driving either RGB LEDs or multiple channels of white LEDs.

HV9989 features a proprietary PWM-dimming control algorithm that achieves a dimming pulse of a few hundred nanoseconds from a Continuous-Conduction Mode (CCM) or Discontinuous-Conduction Mode (DCM) boost converter, while maintaining the instantaneous LED constant current determined by the external reference voltage input. This feature permits a dimming frequency outside of the audible range, and can also yield a wide dimming ratio in excess of 10,000:1 at low dimming frequency. Each of the three channels features individual PWM-dimming and reference voltage inputs.

The switching frequencies of the three converters are controlled by an external clock signal, such that the channels operate at a switching frequency of 1/12th the external clock frequency, and are positioned 120° out-of-phase to reduce the input current ripple.

HV9989 provides a full protection feature set, including output-short and open-circuit protection, for each individual channel that is independent from the other channels.

HV9989 is powered by a built-in 40V linear regulator.

TO OUR VALUED CUSTOMERS

It is our intention to provide our valued customers with the best documentation possible to ensure successful use of your Microchip products. To this end, we will continue to improve our publications to better suit your needs. Our publications will be refined and enhanced as new volumes and updates are introduced.

If you have any questions or comments regarding this publication, please contact the Marketing Communications Department via E-mail at docerrors@microchip.com. We welcome your feedback.

Most Current Data Sheet

To obtain the most up-to-date version of this data sheet, please register at our Worldwide Web site at:

<http://www.microchip.com>

You can determine the version of a data sheet by examining its literature number found on the bottom outside corner of any page. The last character of the literature number is the version number, (e.g., DS30000000A is version A of document DS30000000).

Errata

An errata sheet, describing minor operational differences from the data sheet and recommended workarounds, may exist for current devices. As device/documentation issues become known to us, we will publish an errata sheet. The errata will specify the revision of silicon and revision of document to which it applies.

To determine if an errata sheet exists for a particular device, please check with one of the following:

- Microchip's Worldwide Web site; <http://www.microchip.com>
- Your local Microchip sales office (see last page)

When contacting a sales office, please specify which device, revision of silicon and data sheet (include literature number) you are using.

Customer Notification System

Register on our web site at www.microchip.com to receive the most current information on all of our products.

Pin Diagram

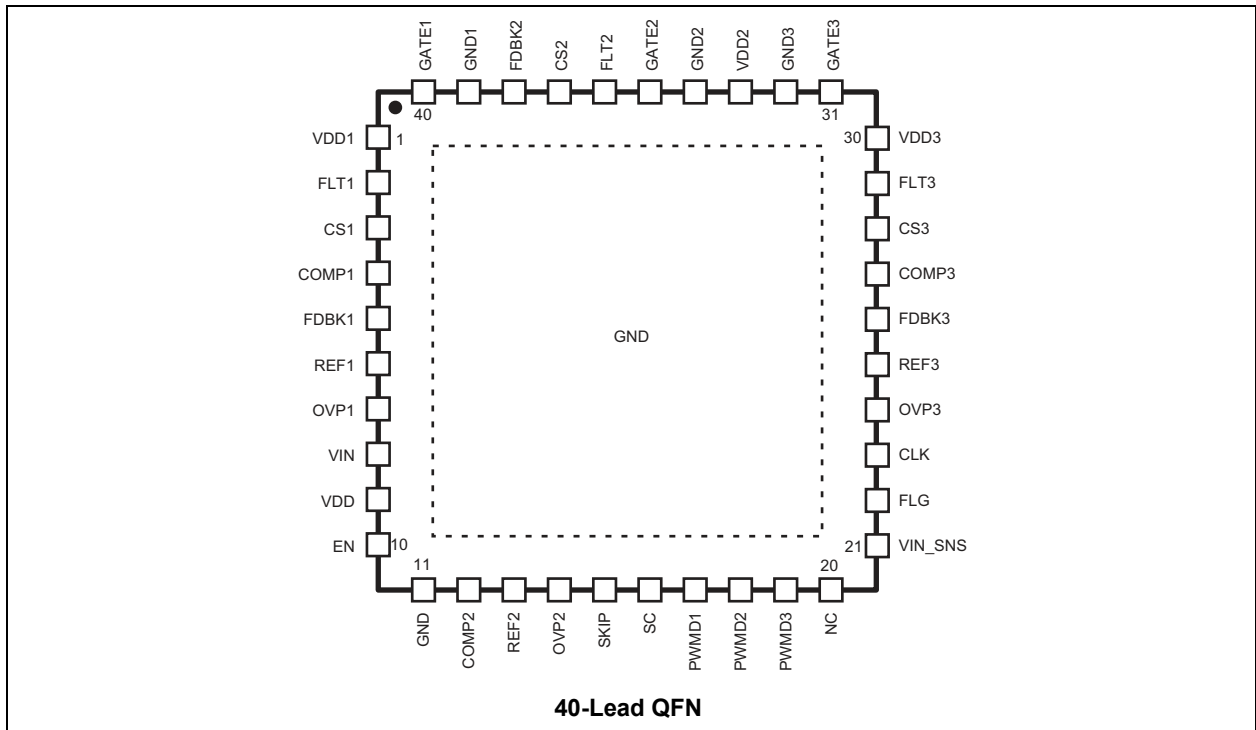

Typical Application Circuit

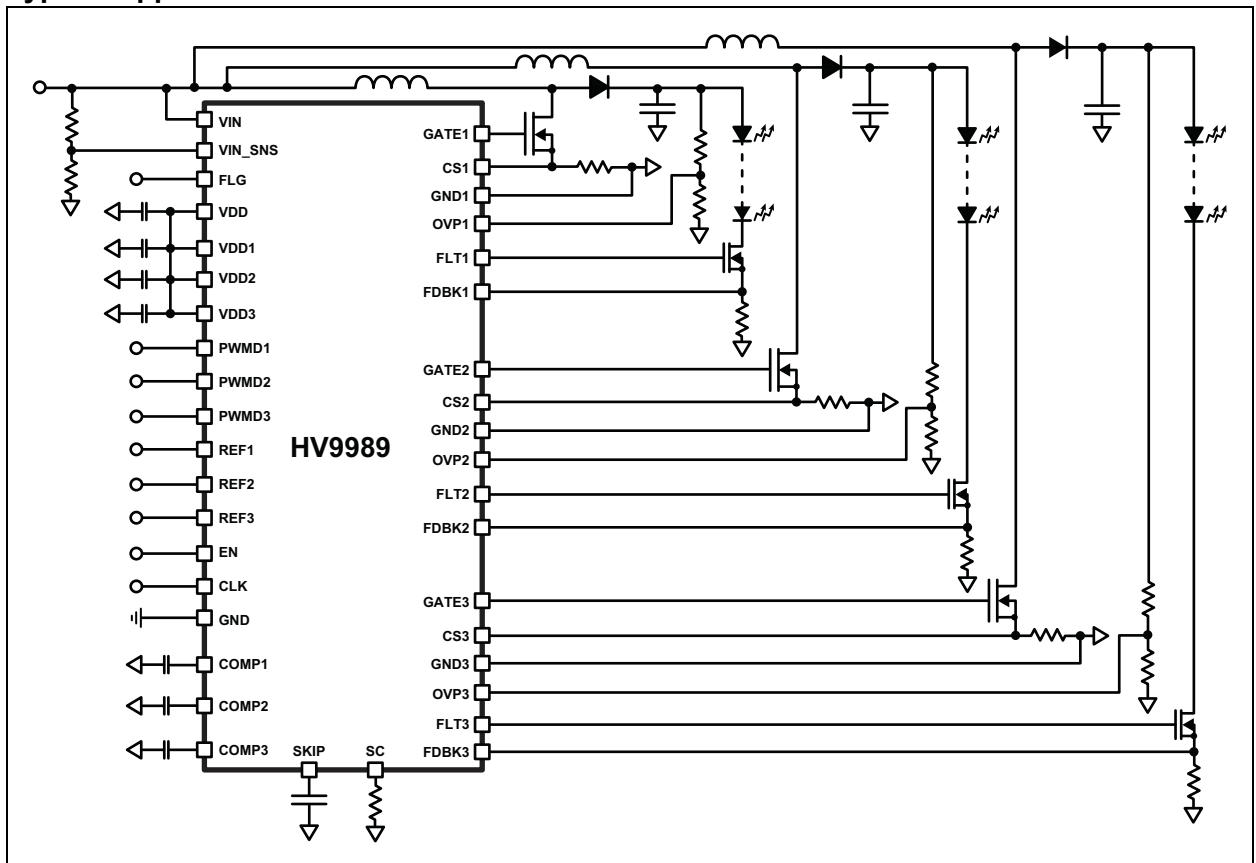

HV9989

1.0 ELECTRICAL CHARACTERISTICS

ABSOLUTE MAXIMUM RATINGS †

V _{IN} to GND	-0.5V to +45V
V _{DD} to GND, V _{DD} 1-3 to GND	-0.3V to +10V
All other pins to GND	-0.3V to (V _{DD} + 0.3V)
Operating temperature	-40°C to +85°C
Storage temperature	-65°C to +150°C
Continuous power dissipation (T _A = +25°C).....	4000 mW

† **Notice:** Stresses above those listed under “Absolute Maximum Ratings” may cause permanent damage to the device. This is a stress rating only and functional operation of the device at those or any other conditions, above those indicated in the operational listings of this specification, is not implied. Exposure to maximum rating conditions for extended periods may affect device reliability.

1.1 ELECTRICAL SPECIFICATIONS

TABLE 1-1: ELECTRICAL CHARACTERISTICS (SHEET 1 OF 3)¹

Symbol	Parameter	Note	Min	Typ	Max	Units	Conditions
Input							
V _{INDC}	Input DC supply voltage	1	10	—	40	V	DC input voltage
I _{INSD}	Shut-down mode supply current	1	—	—	500	μA	EN = 0.8V
I _{IN}	Supply current	—	—	—	4.5	mA	EN ≥ 2.0V; PWMD1 = PWMD2 = PWMD3 = GND
Internal Regulator							
V _{DD}	Internally regulated voltage	1	7.0	—	8.1	V	V _{IN} = 11V; EN = GND; External I _{DD} = 30mA
Δ V _{DD}	Load regulation	—	—	—	80	mV	V _{IN} = 11V; EN = GND; External I _{DD} (A) = 10mA, I _{DD} (B) = 30mA Δ V _{DD} = V _{DD} (A) - V _{DD} (B)
UVLO	V _{DD} under voltage lockout threshold	—	5.9	—	6.4	V	V _{DD} falling
UVLOHYST	V _{DD} under voltage hysteresis	—	-	500	-	mV	V _{DD} rising
PWM Dimming (PWMD1, PWMD2 and PWMD3)							
V _{PWMD(lo)}	PWMD input low voltage	1	—	—	0.8	V	—
V _{PWMD(hi)}	PWMD input high voltage	1	2.0	—	—	V	—
R _{PWMD}	PWMD pull down resistor	—	80	—	160	kΩ	V _{PWMD} = 5.0V
T _d	Delay time to PWMD latch	2	50	—	150	ns	—
T _{DP}	D _{MAX} inhibit delay	2	—	400	—	ns	—

Note 1: Applies over the full operating ambient temperature range of 0°C < T_A < +85°C.

2: For design guidance only.

TABLE 1-1: ELECTRICAL CHARACTERISTICS (CONTINUED) (SHEET 2 OF 3)¹

Symbol	Parameter	Note	Min	Typ	Max	Units	Conditions
Gate (GATE1, GATE2 and GATE3)							
ISOURCE	Gate short circuit current, sourcing	2	0.2	—	—	A	VGATE = 0V
ISINK	Gate sinking current	2	0.4	—	—	A	VGATE = VDD
TRISE	Gate output rise time	—	—	50	85	ns	CGATE = 1.0nF
TFALL	Gate output fall time	—	—	25	45	ns	CGATE = 1.0nF
DMAX	Maximum duty cycle	2	—	91	—	%	—
Over-voltage Protection (OVP1, OVP2 and OVP3)							
VOVP,rising	Over-voltage rising trip point	1	4.7	—	5.4	V	OVP rising
Current Sense (CS1, CS2 and CS3)							
TBLANK	Leading edge blanking	1	210	—	460	ns	—
TDELAY	Delay to GATE	—	—	—	250	ns	50mV overdrive to the current sense comparator
Slope Compensation (SC)							
CSC(EFF)	Effective capacitance	2	0.9	1.0	1.1	nF	—
ΔVSC	VDD-to-SC voltage drop	1	1.25	—	3.25	V	RSC = 120kΩ
Internal Transconductance Opamp (Gm1, Gm2 and Gm3)							
GB	Gain bandwidth product	2	—	1.0	—	MHz	75pF capacitance at COMP pin
AV	Open loop DC gain	—	65	—	—	dB	Output open
KCOMP	COMP-to-CS divider ratio	2	—	1/12	—	—	—
VCM	Input common-mode range	2	-0.3	—	3.0	V	—
VO	Output voltage range	2	0.7	—	6.75	V	—
Gm	Transconductance	—	500	—	700	μA/V	—
VOFFSET	Input offset voltage	—	-5.0	—	5.0	mV	—
IBIAS	Input bias current	2	—	0.5	1.0	nA	—
TR	Recovery delay	2	—	120	—	ns	FDBK = 0V, REF = 0.5V, PWM rising
Oscillator (CLOCK)							
fOSC1	Oscillator frequency	—	—	500	—	kHz	FCLOCK = 6.0MHz
KSW	Oscillator divider ratio	2	—	12	—	-	—
Phi1	GATE1-GATE2 phase delay	2	—	120	—	°	—
Phi1	GATE1-GATE3 phase delay	2	—	240	—	°	—
Oscillator (CLOCK)							
TOFF	CLOCK low time	2	50	—	—	ns	—
TON	CLOCK high time	2	50	—	—	ns	—
VCLOCK,HI	CLOCK input high	1	2.0	—	—	V	—
VCLOCK,L O	CLOCK input low	1	—	—	0.8	V	—

Note 1: Applies over the full operating ambient temperature range of 0°C < T_A < +85°C.

2: For design guidance only.

HV9989

TABLE 1-1: ELECTRICAL CHARACTERISTICS (CONTINUED) (SHEET 3 OF 3)¹

Symbol	Parameter	Note	Min	Typ	Max	Units	Conditions
Disconnect Driver (FLT1, FLT2 and FLT3)							
TRISE,FAULT	Fault output rise time	—	—	—	300	ns	330 pF capacitor at FLTx pin
TFALL,FAULT	Fault output fall time	—	—	—	200	ns	330 pF capacitor at FLTx pin
Short Circuit Protection (all three channels)							
TBLANK,SC	Blanking time	1	400	—	800	ns	—
GSC	Gain for short circuit comparator	—	1.9	2.0	2.1	—	—
Vomin	Minimum current limit threshold	2	0.15	—	—	V	REF = GND
TOFF	Propagation time for short circuit detection	—	—	—	250	ns	FDBK = 2 • REF + 0.1V
HICCUP timer							
IHC,SOURCE	Current source at SKIP pin used for hiccup mode protection	—	—	10	—	μA	—
ΔVCAP	SKIP voltage swing	2	—	4.0	—	V	—
Low output detection (OVP1, OVP2, OVP3, VIN_SNS, FLG)							
VOVP_OS_F	OVP offset voltage	1	-25	—	25	mV	OVP falling
VOVP_OS_R	OVP offset voltage	—	40	—	70	mV	OVP rising
VFLG(LOW)	FLG low voltage	—	0	—	0.4	V	I(FLG) = 1.0mA
VIN_CM	Input common-mode range	2	-0.3	—	5.0	V	—

Note 1: Applies over the full operating ambient temperature range of 0°C < T_A < +85°C.

2: For design guidance only.

TABLE 1-2: THERMAL RESISTANCE

Package	θ _{ja}
40-Lead QFN	24°C/W

2.0 PIN DESCRIPTION

The descriptions of the pins are listed in [Table 2-1](#).

TABLE 2-1: PIN DESCRIPTION (SHEET 1 OF 2)

Pin #	Name	Description
1	VDD1	Power supply pin for channel 1. It can either be connected to the VDD pin or supplied with an external power supply. It must be bypassed with a low ESR capacitor to their respective GND1 (at least 0.1 μ F). All VDD pins (VDD, VDD1-3) must be connected together externally.
2	FLT1	Drives external disconnect switches. The disconnect switches are used to protect the LEDs in case of fault conditions, and also help to provide excellent PWM dimming response by disconnecting and reconnecting the LEDs from the output capacitor during PWM dimming.
3	CS1	Senses the source current of the external power FET used with channel 1. It includes a built-in 210 ns (min) blanking timer.
4	COMP1	Stable closed loop control can be accomplished by connecting a compensation network between the COMP pin and its GND.
5	FDBK1	Provides output current feedback for channel 1 by using a current sense resistor.
6	REF1	The voltage at this pin sets the output current level for channel 1. Recommended voltage range for this pin is 0V-1.25V.
7	OVP1	Provides the over voltage protection for the converter. When the voltage at this pin exceeds 5V, channel 1 of the HV9989 is turned off. The fault is reset by re-enabling the IC using the EN pin.
8	VIN	Input of the internal 40V linear regulator.
9	VDD	Output of the linear regulator. It maintains a regulated 7.75V as long as the voltage of the VIN pin is between 10 and 40V. It must be bypassed with a low ESR capacitor to GND (at least 0.1 μ F). This pin can be used as a power supply for the three channels.
10	EN	When the pin is pulled below 0.8V, the IC goes into a standby mode and draws minimal current.
11	GND	Ground connection for the common circuitry in the HV9989.
12	COMP2	Stable closed loop control can be accomplished by connecting a compensation network between the COMP pin and its GND.
13	REF2	The voltage at this pin sets the output current level for channel 2. Recommended voltage range for this pin is 0-1.25V.
14	OVP2	Provides the over voltage protection for the converter. When the voltage at this pin exceeds 5V, channel 2 of the HV9989 is turned off. The fault is reset by re-enabling the IC using the EN pin.
15	SKIP	Programs the hiccup timer for short circuit fault on any of the three channels. A capacitor to GND programs the hiccup time.
16	SC	Sets the current to program slope compensation voltage ramp at the three CS inputs. Connect a resistor to GND.
17	PWMD1	Used to PWM dim channel 1.
18	PWMD2	Used to PWM dim channel 2.
19	PWMD3	Used to PWM dim channel 3.
20	NC	No connection.
21	VIN_SNS	When voltage at this pin exceeds any of the voltages at OVP 1-3, the high-impedance state is issued at the FLG output.
22	FLG	Open-drain logic output reporting a high-impedance state in the case of any of the OVP 1-3 voltages falling below the VIN_SNS voltage. A hysteresis is added at VIN_SNS to avoid oscillation.
23	CLK	Clock input for the HV9989. The input to the CLK pin should be a TTL compatible square wave signal. The three channels will switch at 1/12th the switching frequency of the signal applied at the CLK pin.

HV9989

TABLE 2-1: PIN DESCRIPTION (CONTINUED) (SHEET 2 OF 2)

Pin #	Name	Description
24	OVP3	Provides the over voltage protection for the converter. When the voltage at this pin exceeds 5V, channel 3 of the HV9989 is turned off. The fault is reset by re-enabling the IC using the EN pin.
25	REF3	The voltage at this pin sets the output current level for channel 3. Recommended voltage range for this pin is 0V-1.25V.
26	FDBK3	Provides output current feedback for channel 3 by using a current sense resistor.
27	COMP3	Stable closed loop control can be accomplished by connecting a compensation network between the COMP pin and its GND.
28	CS3	Used to sense the source current of the external power FET used with channel 3. It includes a built-in 210 ns (min) blanking timer.
29	FLT3	Used to drive external disconnect switches. The disconnect switches are used to protect the LEDs in case of fault conditions and also help to provide excellent PWM dimming response by disconnecting and reconnecting the LEDs from the output capacitor during PWM dimming.
30	VDD3	Power supply pin for channel 3. It can either be connected to the VDD pin or supplied with an external power supply. It must be bypassed with a low ESR capacitor to their respective GND3 (at least 0.1 μ F). All VDD pins (VDD, VDD1-3) must be connected together externally.
31	GATE3	Output gate driver for the external N-channel power MOSFET.
32	GND3	Ground return for channel 3. It is recommended that all the GNDs of the IC be connected together in a STAR connection at the input GND terminal to ensure best performance.
33	VDD2	Power supply pin for channel 2. It can either be connected to the VDD pin or supplied with an external power supply. It must be bypassed with a low ESR capacitor to their respective GND2 (at least 0.1 μ F). All VDD pins (VDD, VDD1-3) must be connected together externally.
34	GND2	Ground return for channel 2. It is recommended that all the GNDs of the IC be connected together in a STAR connection at the input GND terminal to ensure best performance.
35	GATE2	Output gate driver for the external N-channel power MOSFET.
36	FLT2	Used to drive external disconnect switches. The disconnect switches are used to protect the LEDs in case of fault conditions and also help to provide excellent PWM dimming response by disconnecting and reconnecting the LEDs from the output capacitor during PWM dimming.
37	CS2	Used to sense the source current of the external power FET used with channel 2. It includes a built-in 210 ns (min) blanking timer.
38	FDBK2	Provides output current feedback for channel 2 by using a current sense resistor.
39	GND1	Ground return for channel 1. It is recommended that all the GNDs of the IC be connected together in a STAR connection at the input GND terminal to ensure best performance.
40	GATE1	Output gate driver for the external N-channel power MOSFET.

3.0 FUNCTIONAL DESCRIPTION

3.1 Power Topology

HV9989 is a three-channel, switch-mode converter, LED driver designed to control a continuous conduction mode boost or SEPIC device in a constant frequency mode. The IC includes an internal linear regulator, which operates from 10 to 40V input voltages. This device can also be powered directly using the VDD pins and bypassing the internal linear regulator. HV9989 includes features typically required in LED drivers such as open LED protection, output short circuit protection, linear and PWM dimming, programmable input current limiting and accurate control of the LED current. A high current gate drive output enables the controller to be used in high power converters. HV9989 is ideally suited for back-light applications using either RGB or multi-channel white LED configurations.

3.2 Power Supply to the IC (VIN, VDD, VDD1-3)

The HV9989 can be powered directly from its VIN pin that takes a voltage up to 40V. When a voltage is applied at the VIN pin, the HV9989 tries to maintain a constant 7.75V (typ) at the VDD pin. The regulator also has a built in under-voltage lockout which shuts off the IC if the voltage at the VDD pin falls below the UVLO threshold. By connecting this VDD pin to the individual VDD pins of the three channels, the internal regulator can be used to power all three channels in the IC.

In case the internal regulator is not utilized, an external power supply (7-9V) can be used to power the IC. In this case, the power supply is directly connected to the VDD pins and the VIN pin is left unconnected.

All four VDD pins must be bypassed by a low ESR capacitor ($\geq 0.1 \mu\text{F}$) to provide a low impedance path for the high frequency current of the output gate driver. These capacitors must be referenced to the individual grounds for proper noise rejection. Also, in all cases, the four VDD pins must be connected together externally.

The input current drawn from the external power supply (or VIN pin) is a sum of the 4 mA current drawn by the all the internal circuitry (for all three channels) and the current drawn by the gate drivers (which in turn depends on the switching frequency and the gate charge of the external FET).

$$I_{IN} = 4\text{mA} + (Q_{G1} + Q_{G2} + Q_{G3}) \cdot f_s$$

In the preceding equation, f_s is the switching frequency of the converters and Q_{G1-3} are the gate charges of the external FETs (which can be obtained from the FET data sheets).

The EN pin is a TTL-compatible input used to disable the IC. Pulling the EN pin to GND will shut down the IC and reduce the quiescent current drawn by the IC to be lower than 500 μA . If the enable function is not required, the EN pin can be connected to VDD.

3.3 Clock Input (CLK)

The switching frequency of the converters are set by using a TTL-compatible square wave input at the CLK pin. The switching frequencies of the three converters will be 1/12th the frequency of the external clock.

3.4 Current Sense (CS1-3)

The current sense input is used to sense the source current of the switching FET. The CS input of the HV9989 includes a built-in 100 ns (minimum) blanking time to prevent spurious turn off due to the initial current spike when the FET turns on.

The IC includes an internal resistor divider network, which steps down the voltage at the COMP pins by a factor of 12 (including the internal diode drop). This stepped-down voltage is given to one of the comparators as the current reference.

It is recommended that the sense resistor R_{CS} be chosen so as to provide about 250 mV current sense signal.

3.5 Slope Compensation

For continuous conduction mode converters operating in the Constant Frequency mode, slope compensation becomes necessary to ensure stability of the peak current mode controller, if the operating duty cycle is greater than 0.5. Choosing a slope compensation which is one half of the down slope of the inductor current ensures that the converter will be stable for all duty cycles.

Slope compensation in the HV9989 can be programmed by a single resistor at SC input common for all three channels. Assuming a down slope of DS (A/ms) for the inductor current, the SC resistor can be computed as:

$$R_{SC} = \frac{2 \cdot (V_{DD} - \Delta V_{SC})}{DS \cdot 10^6 \cdot R_{CS} C_{SC(EFF)}} \approx \frac{11 \mu\text{V}}{DS \cdot R_{CS} C_{SC(EFF)}}$$

where R_{CS} is the current sense resistor at the CS_X inputs.

3.6 Control of the LED Current

The LED currents in the HV9989 are controlled in a closed-loop manner. The current references which set the three LED currents are provided at the REF pins (REF1-3). This reference voltage is compared to the FDBK voltages (FDBK1-3) which sense the LED currents in the three channels using current sense resistors. The HV9989 includes three 1MHz transconductance amplifiers with tri-state outputs, which are used to close the feedback loops and provide accurate current control. The compensation networks are connected at the COMP pins (COMP1-3).

The outputs of the op amps are buffered and connected to the current sense comparators using 12:1 dividers. The buffer helps to prevent the integrator capacitor from discharging during the PWM dimming state.

The outputs of the op amps are controlled by the signal applied to the PWMD pins (PWMD1-3). When PWMD is high, the output of the op amp is connected to the COMP pin. When PWMD is low, the output is left open. This enables the integrating capacitor to hold the charge when the PWMD signal has turned off the gate drive. When the IC is enabled, the voltage on the integrating capacitor will force the converter into steady state almost instantaneously.

3.7 Linear Dimming

Linear dimming can be accomplished in the HV9989 by varying the voltages at the REF pins. Note that since the HV9989 is a peak current mode controller, it has a minimum on-time for the GATE outputs. This minimum on-time will prevent the converters from completely turning off even when the REF pins are pulled to GND. Thus, linear dimming cannot accomplish true zero LED current. To get zero LED current, PWM dimming has to be used. Note that different signals can be connected to the three REF pins if desired, and they need not be connected together.

Due to the offset voltage of the short circuit comparator, as well as the non-linearity of the X2 gain stage, pulling the REF pin very close to GND would cause the internal short circuit comparator to trigger and shut down the IC. To overcome this, the output of the gain stage is limited to 125mV (minimum), allowing the REF pin to be pulled all the way to 0V without triggering the short circuit comparator.

Note: This control IC is a peak current mode controller; therefore, pulling the REF pin to zero will not cause the LED current to go to zero. The converter will still be operating at its minimum on-time causing a very small current to flow through the LEDs. To get zero LED current, the PWMD input has to be pulled to GND.

3.8 PWM Dimming

PWM dimming in HV9989 can be accomplished using a TTL-compatible square wave source at the PWMD1-3 pins.

HV9989 has an enhanced PWM dimming capability, which allows PWM dimming to widths less than one switching cycle with no drop in the LED current.

The enhanced PWM dimming performance of the HV9989 can be best explained by considering typical boost converter circuits without this functionality. When the PWM dimming pulse becomes very small (less than one switching cycle for a DCM design or less than a few switching cycles for a CCM design), the boost converter is turned off before the input current can reach its steady state value. This causes the input power to drop, which is manifested in the output as a drop in the LED current (Figure 3-1 and Figure 3-2 for a CCM design).

FIGURE 3-1: PWM DIMMING WITH DIMMING ON-TIME FAR GREATER THAN ONE SWITCHING TIME PERIOD

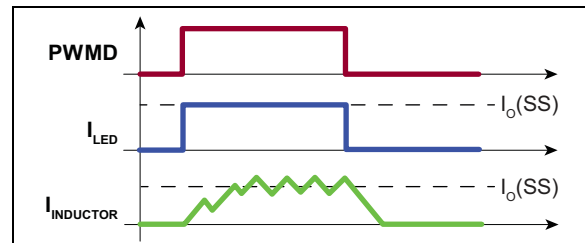
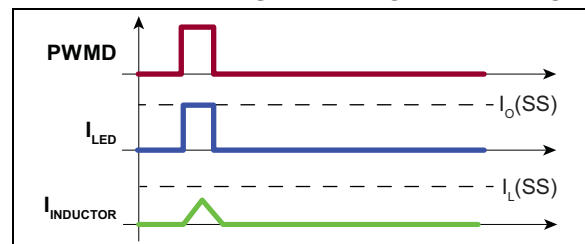

FIGURE 3-2: PWM DIMMING WITH DIMMING ON-TIME EQUAL TO ONE SWITCHING TIME PERIOD



In the above figures, $I_O(SS)$ and $I_L(SS)$ refer to the steady state values (PWMD = 100%) for the output current and inductor current respectively. As can be seen, the inductor current does not rise enough to trip the CS comparator. This causes the closed loop amplifier to lose control of the LED current and COMP rails to VDD.

In the HV9989, however, this problem is overcome by keeping the boost converter ON, even though PWM has gone to zero to ensure enough power is delivered to the output.

Thus, the amplifier still has control over the LED current and the LED current will be in regulation as shown in Figure 3-3.

FIGURE 3-3: PWM DIMMING WITH DIMMING ON-TIME EQUAL TO ONE SWITCHING TIME PERIOD WITH HV9989

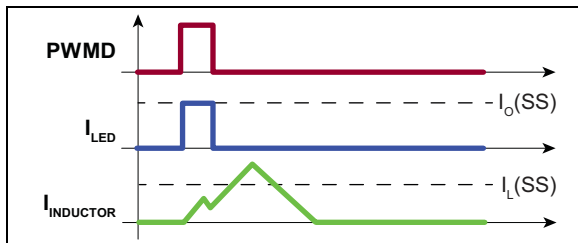

Note that the GATE output is not limited by its maximum duty cycle, DMAX, past the PWM signal trailing edge. The gate is kept on until the corresponding CS reference is met by $I_{INDUCTOR}$.

When the PWM signal is high, the GATE and FLT pins are enabled and the output of the transconductance op amp is connected to the external compensation network. Thus, the internal amplifier controls the output current. When the PWM signal goes low, the output of the transconductance amplifier is disconnected from the compensation network. Thus, the integrating capacitor maintains the voltage across it. The FLT pin goes low, turning off the disconnect switch. However, the boost FET is kept running.

Note that disconnecting the LED load during PWM dimming causes the energy stored in the inductor to be dumped into the output capacitor. The chosen filter

capacitor should be large enough so that it can absorb the inductor energy without a significant change of the voltage across it. If the capacitor voltage change is significant, it would cause a turn-on spike in the inductor current when PWM goes high.

3.9 SKIP Timer Logic

During the Power-on Reset (POR) state upon startup, both GATE and FLT outputs are disabled. The COMP pins and the SKIP pin are pulled to GND.

When an output over-current condition is detected in any individual channel, the corresponding GATE and FLT outputs are disabled, and the corresponding COMP output is pulled to GND. The remaining channel GATE, FLT and COMP outputs are not affected. The SKIP pin is pulled to GND. If pulling FLT low clears the over-current condition in the faulty channel, and once the voltage at the SKIP pin falls below 1.0V, the capacitor at the SKIP pin is released and is charged slowly by a 10 μ A current source. Once the capacitor is charged to 5.0V, the COMP pins are released and GATE and FLT pins are allowed to turn on. If the hiccup time is long enough, it will ensure that the compensation networks are all completely discharged and that the converters start at minimum duty cycle.

If, during the charging phase of the SKIP output, an over-current condition is detected in another channel, the SKIP pin is pulled to GND again, and the ramp starts over. All faulty channels make an attempt to recover at the same time when the FLT capacitor is charged to 5.0V. Operation of other “good” channel(s) is not affected by the SKIP pin status.

The hiccup timing capacitor can be programmed as:

$$C_{RAMP} = \frac{10\mu A \cdot t_{HICCUP}}{4V}$$

FIGURE 3-4: DEEP PWM DIMMING PERFORMANCE: LED CURRENT MAINTAINED IN REGULATION

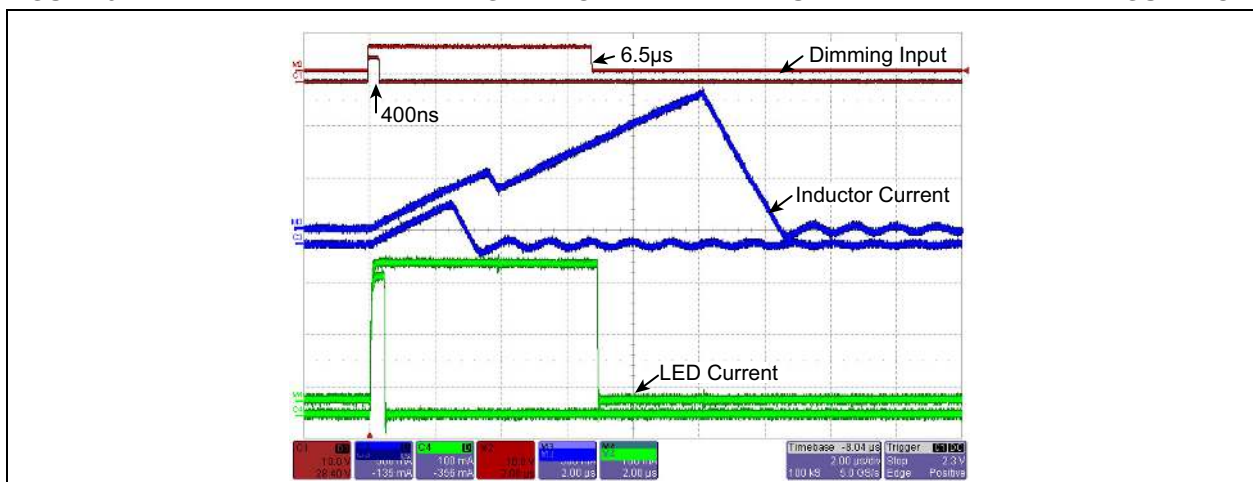

3.10 Short Circuit Protection

When a short circuit condition is detected (output current becomes higher than twice the steady state current), the GATE and FLT outputs are pulled low. As soon as the disconnect FET is turned off, the output current goes to zero and the short circuit condition disappears. At this time, the hiccup timer is started. Once the timing is complete, the converter attempts to restart. If the fault condition still persists, the converter shuts down and goes through the cycle again. If the fault condition is cleared (due to a momentary output short) the converter will start regulating the output current normally. This allows the LED driver to recover from accidental shorts without having to reset the IC.

During short circuit conditions, there are two conditions that determine the hiccup time.

The first condition is the time required to discharge the compensation capacitors. Assuming a pole-zero R-C network at the COMP pin (series combination of R_Z and C_Z in parallel with C_C),

$$t_{COMP,n} = 3 \cdot R_{Zn} \cdot C_{Zn}$$

where n refers to the channel number.

If the compensation networks are only type 1 (single capacitor), then:

$$t_{COMP,n} = 3 \cdot 300\Omega \cdot C_{Cn}$$

Thus, the maximum compensation time required can be computed as:

$$t_{COMP,max} = \max(t_{COMP1}, t_{COMP2}, t_{COMP3})$$

The second condition is the time required for the inductors to completely discharge following a short circuit. This time can be computed as:

$$t_{ind,n} = \frac{\pi}{4} \sqrt{L_n \cdot C_{On}}$$

where L and C_O are the input inductor and output capacitor of each power stage.

Thus, the maximum time required to discharge the inductors can be computed as:

$$t_{IND,MAX} = \max(t_{IND1}, t_{IND2}, t_{IND3})$$

The hiccup time is then chosen as:

$$t_{HICCUP} = \max(t_{COMP,MAX}, t_{IND,MAX})$$

3.11 False Triggering of the Short Circuit Comparator During PWM Dimming

During PWM dimming, the parasitic capacitance of the LED string causes a spike in the output current when the disconnect FET is turned on. If this spike is detected by the short circuit comparator, it will cause the IC to falsely detect an over current condition and shut down.

In the HV9989, to prevent these false triggers, there is a built-in 500 ns blanking network for the short circuit comparator. This blanking network is activated when the PWMD input goes high. Thus, the short circuit comparator will not see the spike in the LED current during the PWM dimming turn-on transition. Once the blanking timer is complete, the short circuit comparator will start monitoring the output current. Thus, the total delay time for detecting a short circuit will depend on the condition of the PWMD input.

If the output short circuit exists before the PWM-dimming signal goes high, the total detection time will be:

$$t_{DETECT1} = t_{BLANK} + t_{DELAY} \approx 950ns(max)$$

If the short circuit occurs when the PWM dimming signal is already high, the time to detect will be:

$$t = t \approx 250ns(max)$$

3.12 Over-voltage Protection

The HV9989 provides latching over-voltage protection. When the load is disconnected in a boost converter, the output voltage rises as the output capacitor starts charging. When the output voltage reaches the OVP rising threshold, the HV9989 detects an over-voltage condition and turns off the converter. The converter is turned back on only when the EN pin is toggled.

In most designs, the lower threshold voltage of the over-voltage protection when the converter will be turned on will be more than the LED string voltage. Thus, when the LED load is reconnected to the output of the converter, the voltage differential between the actual output voltage and the LED string voltage will cause a spike in the output current when the FLT signal goes high. This causes a short circuit to be detected and the HV9989 will go into short circuit protection. This behavior continues until the output voltage becomes lower than the LED string voltage, at which point no fault will be detected and normal operation of the circuit will commence.

3.13 Input-Output Voltage Comparator

The HV9989 includes a circuit for detecting any of the three boost converter output voltages falling below the input voltage. The input voltage is monitored at the VIN_SNS input using a resistor divider having the same ratio as the OVP1-3 resistor dividers. An open-drain FLG output reports a high impedance state when the voltage at either of the OVP1-3 inputs falls below

VIN_SNS. The FLG output recovers into the low-impedance state when the faulty OVP input voltage becomes greater than VIN_SNS by a 55mV hysteresis.

A pull-up resistor should be added at FLG. The FLG output can sink up to 1.0mA.

FIGURE 3-5: TIMER CIRCUIT

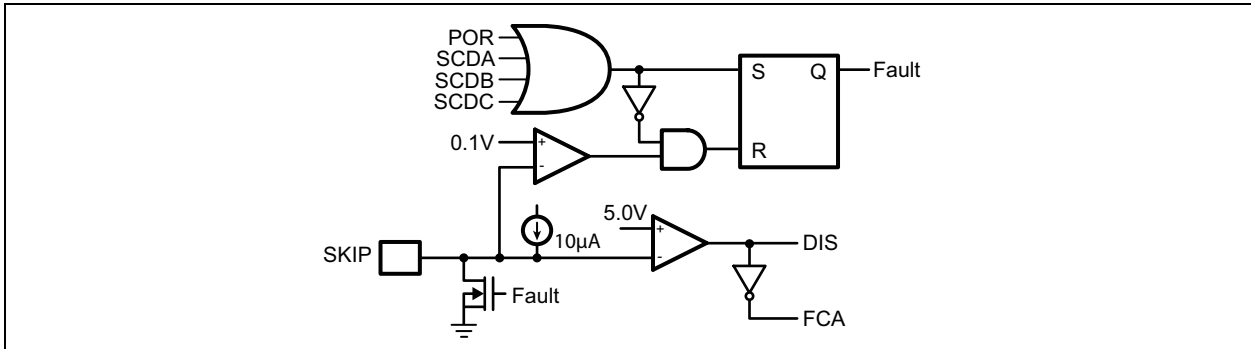

HV9989

FIGURE 3-6: INTERNAL BLOCK DIAGRAM

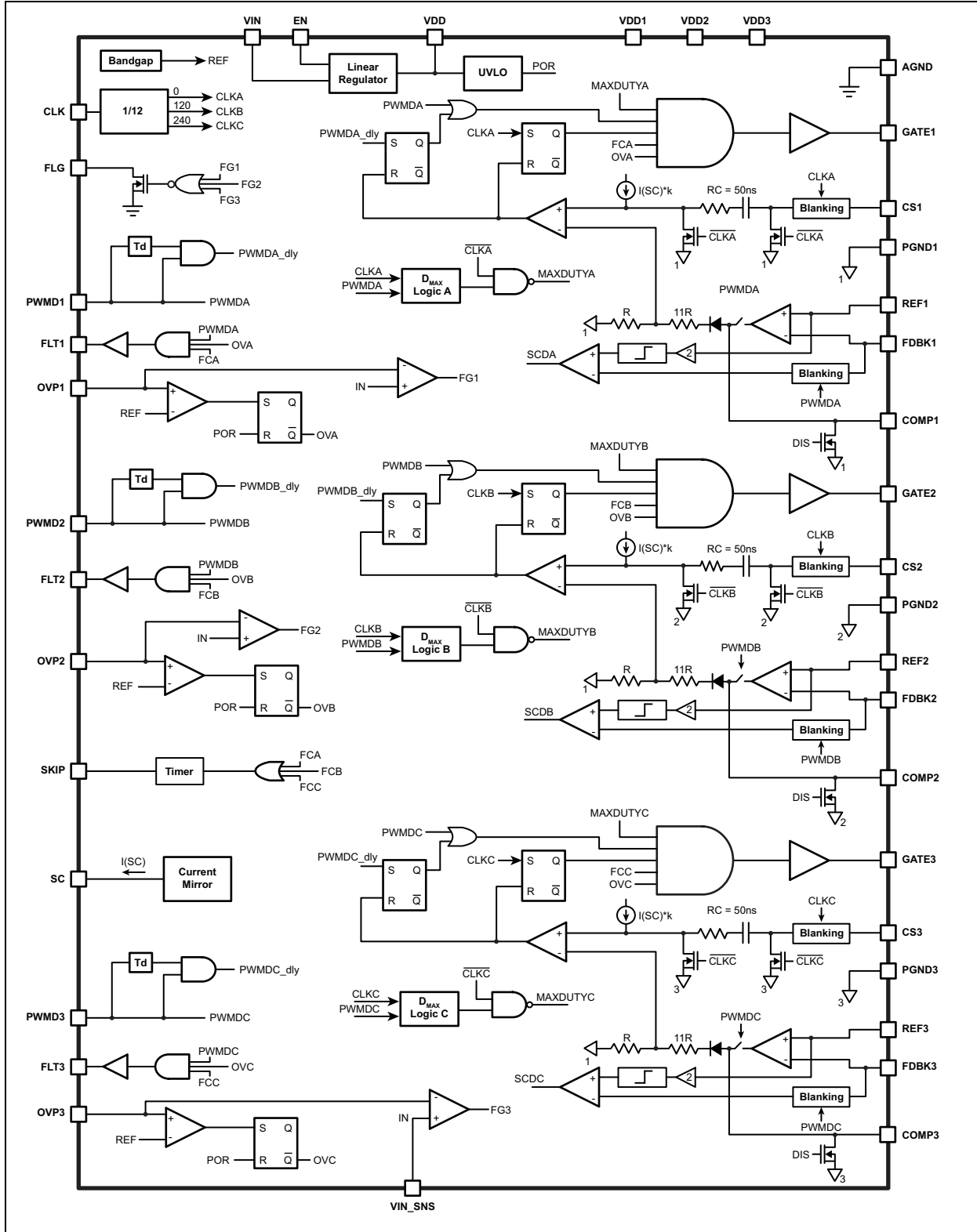

4.0 PACKAGING INFORMATION

4.1 Package Marking Information

40-Lead QFN

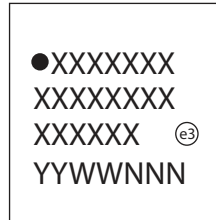

Example

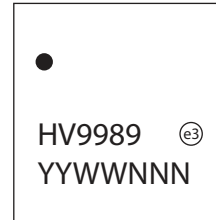

Legend:	XX...X	Product Code or Customer-specific information
	Y	Year code (last digit of calendar year)
	YY	Year code (last 2 digits of calendar year)
	WW	Week code (week of January 1 is week '01')
	NNN	Alphanumeric traceability code
	(e3)	Pb-free JEDEC designator for Matte Tin (Sn)
	*	This package is Pb-free. The Pb-free JEDEC designator (e3) can be found on the outer packaging for this package.
Note:	In the event the full Microchip part number cannot be marked on one line, it will be carried over to the next line, thus limiting the number of available characters for customer-specific information.	

HV9989

40 Lead QFN

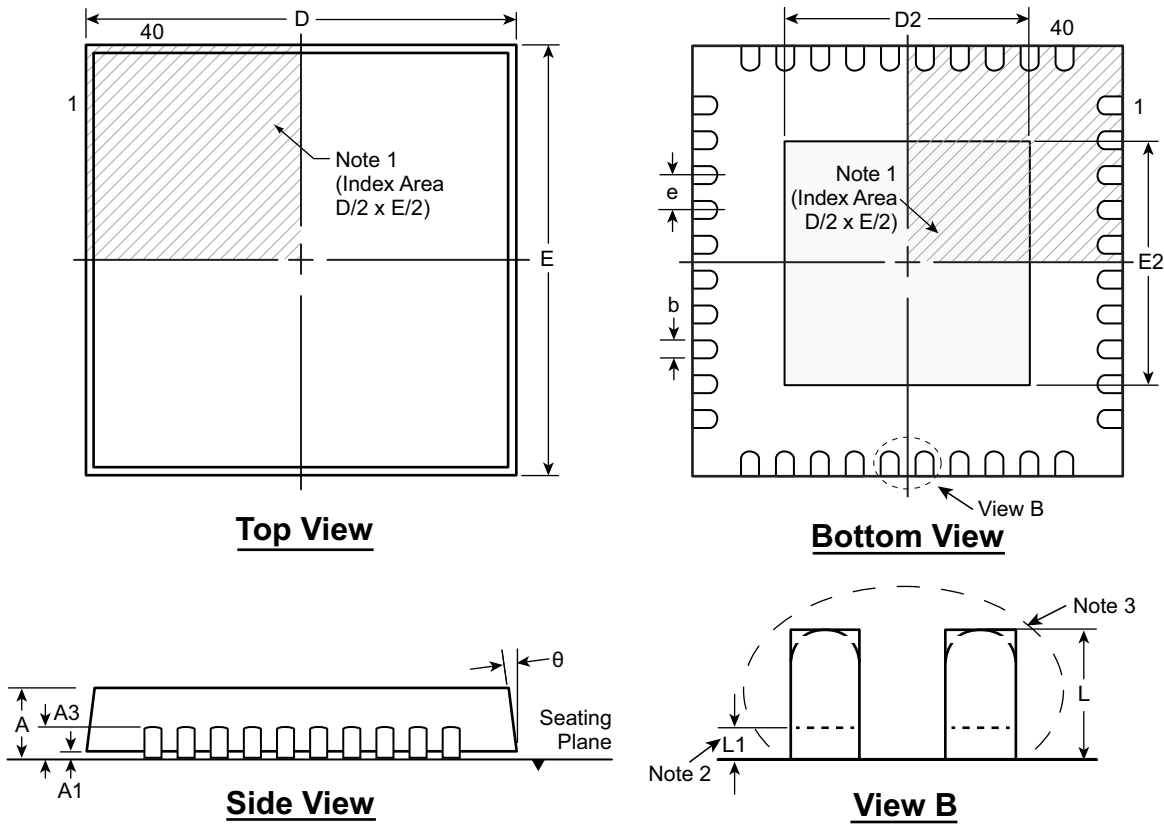

Notes:

- 1: A Pin 1 identifier must be located in the index area indicated. The Pin 1 identifier can be: a molded mark/ identifier; an embedded metal marker; or a printed indicator.
- 2: Depending on the method of manufacturing, a maximum of 0.15mm pullback (L1) may be present.
- 3: The inner tip of the lead may be either rounded or square.
- 4: For the most current package drawings, please see the Microchip Packaging Specification located at <http://www.microchip.com/packaging>

Symbol	A	A1	A3	b	D	D2	E	E2	e	L	L1	θO	
Dimension (mm)	MIN	0.80	0.00	0.20	0.18	5.85*	1.05	5.85*	1.05	0.50	0.30†	0.00	0
	NOM	0.90	0.02		0.25	6.00	-	6.00	-		0.40†	-	-
	MAX	1.00	0.05	REF	0.30	6.15*	4.45	6.15*	4.45	BSC	0.50†	0.15	14

JEDEC Registration MO-220, Variation VJJD-6, Issue K, June 2006.

* This dimension is not specified in the JEDEC drawing.

† This dimension differs from the JEDEC drawing.

Drawings not to scale.

APPENDIX A: REVISION HISTORY

Revision A (May 2014)

- Original Release of this Document.

Revision B (September 2014)

- Updated template to the Microchip template
- Updated the package marking information

THE MICROCHIP WEB SITE

Microchip provides online support via our WWW site at www.microchip.com. This web site is used as a means to make files and information easily available to customers. Accessible by using your favorite Internet browser, the web site contains the following information:

- **Product Support** – Data sheets and errata, application notes and sample programs, design resources, user's guides and hardware support documents, latest software releases and archived software
- **General Technical Support** – Frequently Asked Questions (FAQ), technical support requests, online discussion groups, Microchip consultant program member listing
- **Business of Microchip** – Product selector and ordering guides, latest Microchip press releases, listing of seminars and events, listings of Microchip sales offices, distributors and factory representatives

CUSTOMER CHANGE NOTIFICATION SERVICE

Microchip's customer notification service helps keep customers current on Microchip products. Subscribers will receive e-mail notification whenever there are changes, updates, revisions or errata related to a specified product family or development tool of interest.

To register, access the Microchip web site at www.microchip.com. Under "Support", click on "Customer Change Notification" and follow the registration instructions.

CUSTOMER SUPPORT

Users of Microchip products can receive assistance through several channels:

- Distributor or Representative
- Local Sales Office
- Field Application Engineer (FAE)
- Technical Support

Customers should contact their distributor, representative or Field Application Engineer (FAE) for support. Local sales offices are also available to help customers. A listing of sales offices and locations is included in the back of this document.

Technical support is available through the web site at: <http://microchip.com/support>

PRODUCT IDENTIFICATION SYSTEM

To order or obtain information, e.g., on pricing or delivery, refer to the factory or the listed sales office.

<u>PART NO.</u>	<u>XX</u>	<u>X</u>	<u>X</u>
Device	Package Options	Environmental	Reel
<p>Device: HV9989 = Three-channel CCM/DCM Boost LED Driver with Sub-microsecond PWM dimming</p> <p>Package: K6 = 40-lead (6x6) QFN</p> <p>Environmental: G = Lead (Pb)-free/ROHS-compliant package</p> <p>Reel: (nothing) = Tray M935 = Reel</p>	<p>Examples:</p> <p>a) HV9989K6-G: 40-lead QFN package, 490/Tray.</p> <p>b) HV9989K6-G-M935: 40-lead QFN package, 2000/Reel.</p>		

Note the following details of the code protection feature on Microchip devices:

- Microchip products meet the specification contained in their particular Microchip Data Sheet.
- Microchip believes that its family of products is one of the most secure families of its kind on the market today, when used in the intended manner and under normal conditions.
- There are dishonest and possibly illegal methods used to breach the code protection feature. All of these methods, to our knowledge, require using the Microchip products in a manner outside the operating specifications contained in Microchip's Data Sheets. Most likely, the person doing so is engaged in theft of intellectual property.
- Microchip is willing to work with the customer who is concerned about the integrity of their code.
- Neither Microchip nor any other semiconductor manufacturer can guarantee the security of their code. Code protection does not mean that we are guaranteeing the product as “unbreakable.”

Code protection is constantly evolving. We at Microchip are committed to continuously improving the code protection features of our products. Attempts to break Microchip's code protection feature may be a violation of the Digital Millennium Copyright Act. If such acts allow unauthorized access to your software or other copyrighted work, you may have a right to sue for relief under that Act.

Information contained in this publication regarding device applications and the like is provided only for your convenience and may be superseded by updates. It is your responsibility to ensure that your application meets with your specifications. MICROCHIP MAKES NO REPRESENTATIONS OR WARRANTIES OF ANY KIND WHETHER EXPRESS OR IMPLIED, WRITTEN OR ORAL, STATUTORY OR OTHERWISE, RELATED TO THE INFORMATION, INCLUDING BUT NOT LIMITED TO ITS CONDITION, QUALITY, PERFORMANCE, MERCHANTABILITY OR FITNESS FOR PURPOSE. Microchip disclaims all liability arising from this information and its use. Use of Microchip devices in life support and/or safety applications is entirely at the buyer's risk, and the buyer agrees to defend, indemnify and hold harmless Microchip from any and all damages, claims, suits, or expenses resulting from such use. No licenses are conveyed, implicitly or otherwise, under any Microchip intellectual property rights.

Trademarks

The Microchip name and logo, the Microchip logo, dsPIC, FlashFlex, flexPWR, JukeBlox, KEELOQ, KEELOQ logo, Klear, LANCheck, MediaLB, MOST, MOST logo, MPLAB, OptoLyzer, PIC, PICSTART, PIC³² logo, RightTouch, SpyNIC, SST, SST Logo, SuperFlash and UNI/O are registered trademarks of Microchip Technology Incorporated in the U.S.A. and other countries.

The Embedded Control Solutions Company and mTouch are registered trademarks of Microchip Technology Incorporated in the U.S.A.

Analog-for-the-Digital Age, BodyCom, chipKIT, chipKIT logo, CodeGuard, dsPICDEM, dsPICDEM.net, ECAN, In-Circuit Serial Programming, ICSP, Inter-Chip Connectivity, KlearNet, KlearNet logo, MiWi, MPASM, MPF, MPLAB Certified logo, MPLIB, MPLINK, MultiTRAK, NetDetach, Omniscient Code Generation, PICDEM, PICDEM.net, PICkit, PICtail, RightTouch logo, REAL ICE, SQI, Serial Quad I/O, Total Endurance, TSHARC, USBCheck, VariSense, ViewSpan, WiperLock, Wireless DNA, and ZENA are trademarks of Microchip Technology Incorporated in the U.S.A. and other countries.

SQTP is a service mark of Microchip Technology Incorporated in the U.S.A.

Silicon Storage Technology is a registered trademark of Microchip Technology Inc. in other countries.

GestIC is a registered trademarks of Microchip Technology Germany II GmbH & Co. KG, a subsidiary of Microchip Technology Inc., in other countries.

All other trademarks mentioned herein are property of their respective companies.

© 2014, Microchip Technology Incorporated, Printed in the U.S.A., All Rights Reserved.

ISBN: 978-1-63276-579-6

QUALITY MANAGEMENT SYSTEM
CERTIFIED BY DNV
== ISO/TS 16949 ==

Microchip received ISO/TS-16949:2009 certification for its worldwide headquarters, design and wafer fabrication facilities in Chandler and Tempe, Arizona; Gresham, Oregon and design centers in California and India. The Company's quality system processes and procedures are for its PIC® MCUs and dsPIC® DSCs, KEELOQ® code hopping devices, Serial EEPROMs, microperipherals, nonvolatile memory and analog products. In addition, Microchip's quality system for the design and manufacture of development systems is ISO 9001:2000 certified.



MICROCHIP

Worldwide Sales and Service

AMERICAS

Corporate Office
2355 West Chandler Blvd.
Chandler, AZ 85224-6199
Tel: 480-792-7200
Fax: 480-792-7277
Technical Support:
<http://www.microchip.com/support>
Web Address:
www.microchip.com

Atlanta
Duluth, GA
Tel: 678-957-9614
Fax: 678-957-1455

Austin, TX
Tel: 512-257-3370

Boston
Westborough, MA
Tel: 774-760-0087
Fax: 774-760-0088

Chicago
Itasca, IL
Tel: 630-285-0071
Fax: 630-285-0075

Cleveland
Independence, OH
Tel: 216-447-0464
Fax: 216-447-0643

Dallas
Addison, TX
Tel: 972-818-7423
Fax: 972-818-2924

Detroit
Novi, MI
Tel: 248-848-4000

Houston, TX
Tel: 281-894-5983

Indianapolis
Noblesville, IN
Tel: 317-773-8323
Fax: 317-773-5453

Los Angeles
Mission Viejo, CA
Tel: 949-462-9523
Fax: 949-462-9608

New York, NY
Tel: 631-435-6000

San Jose, CA
Tel: 408-735-9110

Canada - Toronto
Tel: 905-673-0699
Fax: 905-673-6509

ASIA/PACIFIC

Asia Pacific Office
Suites 3707-14, 37th Floor
Tower 6, The Gateway
Harbour City, Kowloon
Hong Kong
Tel: 852-2943-5100
Fax: 852-2401-3431

Australia - Sydney
Tel: 61-2-9868-6733
Fax: 61-2-9868-6755

China - Beijing
Tel: 86-10-8569-7000
Fax: 86-10-8528-2104

China - Chengdu
Tel: 86-28-8665-5511
Fax: 86-28-8665-7889

China - Chongqing
Tel: 86-23-8980-9588
Fax: 86-23-8980-9500

China - Hangzhou
Tel: 86-571-8792-8115
Fax: 86-571-8792-8116

China - Hong Kong SAR
Tel: 852-2943-5100
Fax: 852-2401-3431

China - Nanjing
Tel: 86-25-8473-2460
Fax: 86-25-8473-2470

China - Qingdao
Tel: 86-532-8502-7355
Fax: 86-532-8502-7205

China - Shanghai
Tel: 86-21-5407-5533
Fax: 86-21-5407-5066

China - Shenyang
Tel: 86-24-2334-2829
Fax: 86-24-2334-2393

China - Shenzhen
Tel: 86-755-8864-2200
Fax: 86-755-8203-1760

China - Wuhan
Tel: 86-27-5980-5300
Fax: 86-27-5980-5118

China - Xian
Tel: 86-29-8833-7252
Fax: 86-29-8833-7256

China - Xiamen
Tel: 86-592-2388138
Fax: 86-592-2388130

China - Zhuhai
Tel: 86-756-3210040
Fax: 86-756-3210049

ASIA/PACIFIC

India - Bangalore
Tel: 91-80-3090-4444
Fax: 91-80-3090-4123

India - New Delhi
Tel: 91-11-4160-8631
Fax: 91-11-4160-8632

India - Pune
Tel: 91-20-3019-1500

Japan - Osaka
Tel: 81-6-6152-7160
Fax: 81-6-6152-9310

Japan - Tokyo
Tel: 81-3-6880-3770
Fax: 81-3-6880-3771

Korea - Daegu
Tel: 82-53-744-4301
Fax: 82-53-744-4302

Korea - Seoul
Tel: 82-2-554-7200
Fax: 82-2-558-5932 or
82-2-558-5934

Malaysia - Kuala Lumpur
Tel: 60-3-6201-9857
Fax: 60-3-6201-9859

Malaysia - Penang
Tel: 60-4-227-8870
Fax: 60-4-227-4068

Philippines - Manila
Tel: 63-2-634-9065
Fax: 63-2-634-9069

Singapore
Tel: 65-6334-8870
Fax: 65-6334-8850

Taiwan - Hsin Chu
Tel: 886-3-5778-366
Fax: 886-3-5770-955

Taiwan - Kaohsiung
Tel: 886-7-213-7830

Taiwan - Taipei
Tel: 886-2-2508-8600
Fax: 886-2-2508-0102

Thailand - Bangkok
Tel: 66-2-694-1351
Fax: 66-2-694-1350

EUROPE

Austria - Wels
Tel: 43-7242-2244-39
Fax: 43-7242-2244-393

Denmark - Copenhagen
Tel: 45-4450-2828
Fax: 45-4485-2829

France - Paris
Tel: 33-1-69-53-63-20
Fax: 33-1-69-30-90-79

Germany - Dusseldorf
Tel: 49-2129-3766400

Germany - Munich
Tel: 49-89-627-144-0
Fax: 49-89-627-144-44

Germany - Pforzheim
Tel: 49-7231-424750

Italy - Milan
Tel: 39-0331-742611
Fax: 39-0331-466781

Italy - Venice
Tel: 39-049-7625286

Netherlands - Drunen
Tel: 31-416-690399
Fax: 31-416-690340

Poland - Warsaw
Tel: 48-22-3325737

Spain - Madrid
Tel: 34-91-708-08-90
Fax: 34-91-708-08-91

Sweden - Stockholm
Tel: 46-8-5090-4654

UK - Wokingham
Tel: 44-118-921-5800
Fax: 44-118-921-5820

03/25/14