

Metal Oxide Varistor : TVT Series



Thermally Protected Varistor Series

■ Features

1. RoHS compliant
2. Halogen-free series are available
3. Two-terminal or three-terminal thermally protected metal oxide varistors, and three-terminal type is available for failure indication.
4. Product with remote signal function is available
5. Body size: 14, 20, 25 mm
6. Working voltage: 50Vac ~1000Vac
7. Operating temperature range: -40°C ~ +105°C
Storage temperature range: -40°C ~ +110°C
8. Agency approval:
 - TVT14 and TVT20 series: UL1449 4th & cUL/ TUV/CQC
 - TVT25 series: UL1449 4th & cUL/ TUV
9. UL1449 4th SPD Type: Type 4 Assemblies
10. Suitable for wave flow soldering



■ Recommended Applications

1. TVSS modules
2. Uninterruptible power supplies
3. Power supplies
4. Lighting products
5. Communication products
6. Smart meter
7. Photovoltaic industry

■ Part Number Code

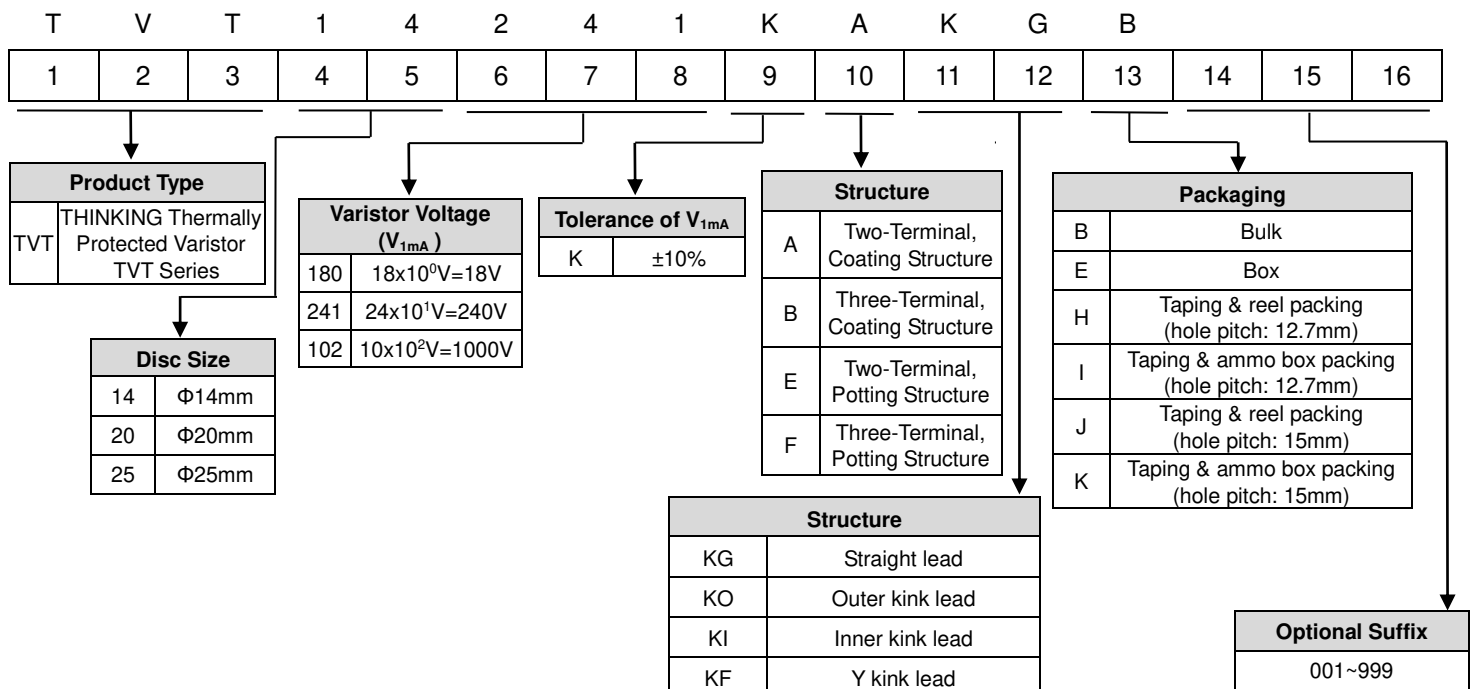

Metal Oxide Varistor : TVT Series



Thermally Protected Varistor Series

■ Structure and Dimensions (Coating Structure)

● Straight Lead

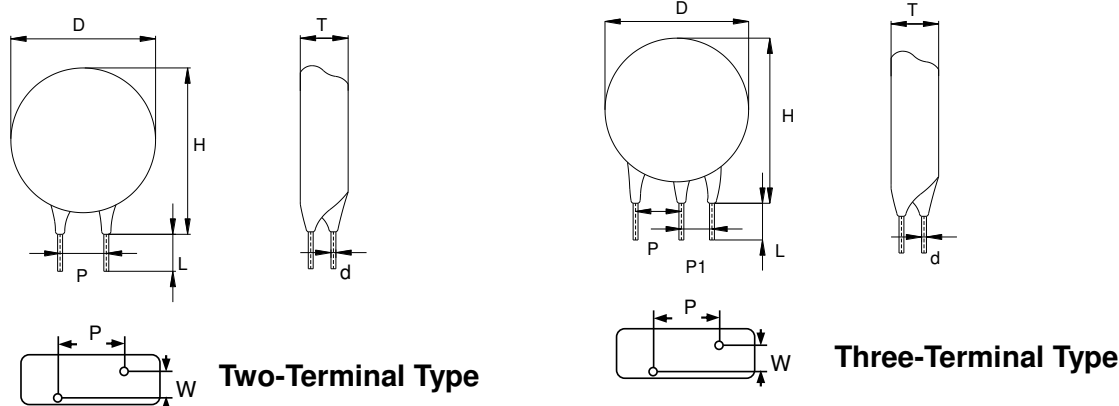

(Unit: mm)

Series	Lead Type	D	P±1	P1±1	H _{max.}	Φd±0.5	L _{min.}	W	T _{max}	
TVT14820~122	Two-Terminal Type	15.5~18.5	7.5	--	24	0.8	6	Please Refer to Electrical Characteristics		
TVT14820~122	Three-Terminal Type	15.5~18.5	7.5	5.0	24	0.8	6			
TVT20820~681	Two-Terminal Type	19.5~23.5	7.5	--	27	0.8	6			
TVT20751~182						1.0				
TVT20821~681	Three-Terminal Type	19.5~23.5	7.5	5.0	27	0.8	6			
TVT20751~182						1.0				
TVT25201~122	Two-Terminal Type	26~29	10	---	33	1.0	6			
TVT25201~122	Three-Terminal Type	26~29	10	5.0	33	1.0	6			

● Outer Kink Lead

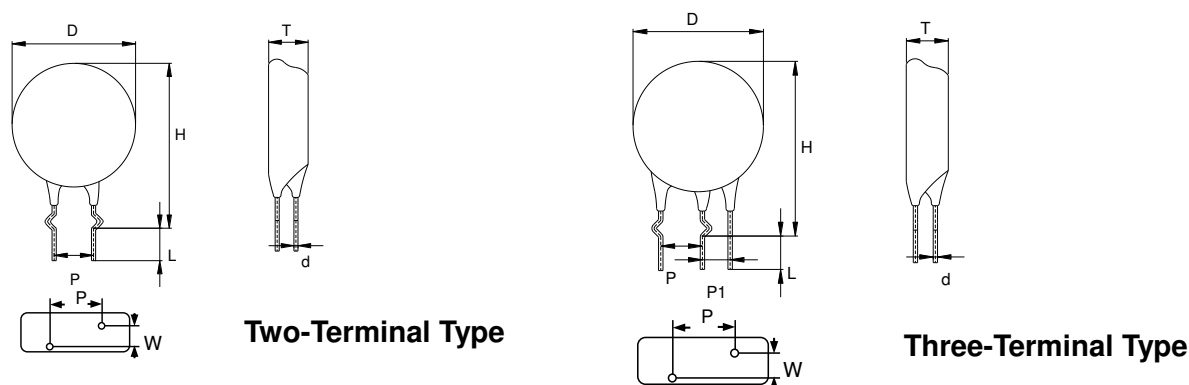

● Inner Kink Lead

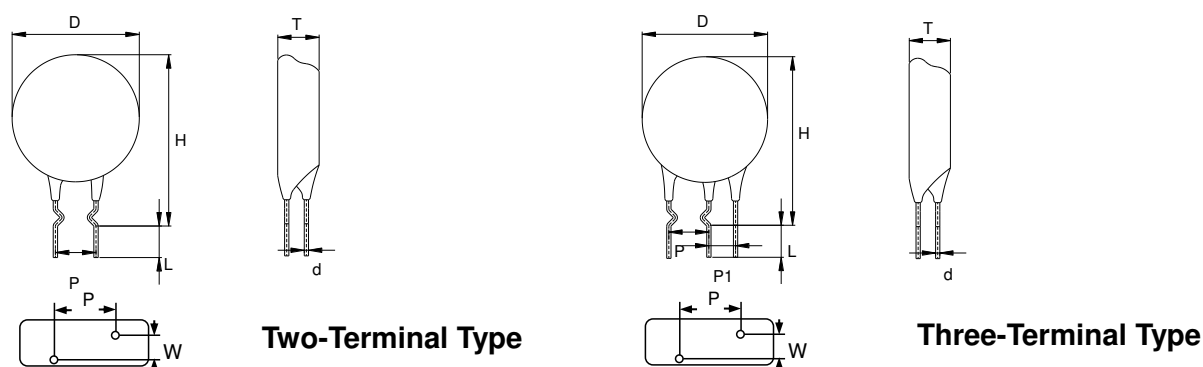

Metal Oxide Varistor : TVT Series

Thermally Protected Varistor Series



● Y Kink Lead (Bulk)

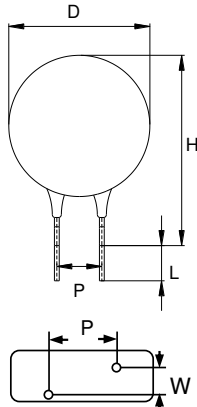

Two-Terminal Type

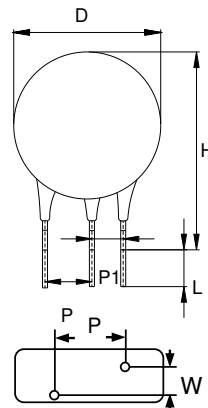
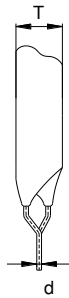

Three-Terminal Type



● Y Kink Lead (Taping Type)

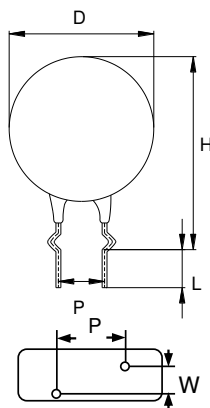

Two-Terminal Type

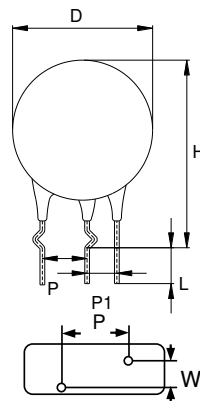
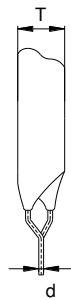

Three-Terminal Type



(Unit: mm)

Series	Lead Type	D	P±1	P1±1	H _{max.}	Φd±0.5	L _{min.}	W	T _{max}
TVT14820~122	Two-Terminal Type	15.5~18.5	7.5	--	26.5	0.8	6	Please Refer to Electrical Characteristics	
TVT14820~122	Three-Terminal Type	15.5~18.5	7.5	5.0	26.5	0.8	6		
TVT20820~681	Two-Terminal Type	19.5~23.5	7.5	--	31.5	0.8	6		
TVT20751~182						1.0			
TVT20820~681	Three-Terminal Type	19.5~23.5	7.5	5.0	31.5	0.8	6		
TVT20751~182						1.0			
TVT25201~122	Two-Terminal Type	26~29	10	---	37	1.0	6		
TVT25201~122	Three-Terminal Type	26~29	10	5.0	37	1.0	6		

Note: L of taping packing is not defined.

Metal Oxide Varistor : TVT Series

Thermally Protected Varistor Series



■ Structure and Dimensions (Potting Structure)

- TVT14*KEKF Type

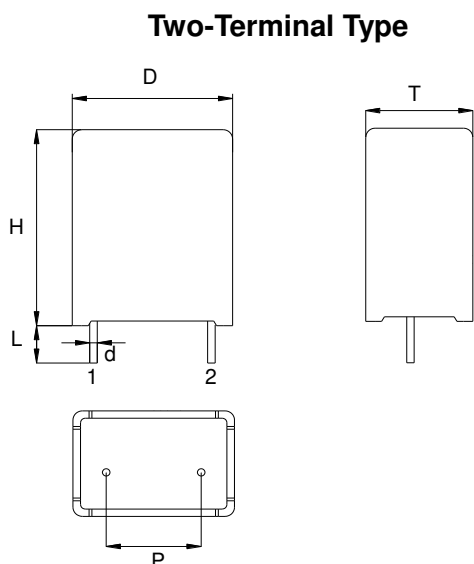

Figure 14-1

(Unit: mm)

Series	Lead Type	Varistor Voltage	D±1	H±1	T±1	L±1	Φd±0.05	P±0.5	Figure
TVT14*KEKF*	Two-Terminal Type	(820~561)	17	20	11.5	4.5	0.8	10	14-1

- TVT14*KFKF Type

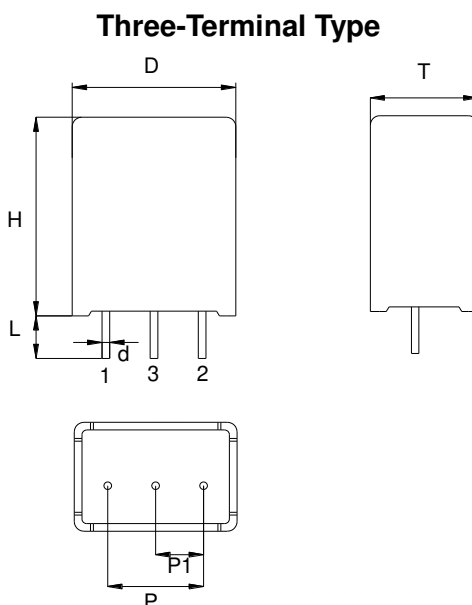

Figure 14-2

(Unit: mm)

Series	Lead Type	Varistor Voltage	D±1	H±1	T±1	L±1	Φd±0.05	P±0.5	P1±0.5	Figure
TVT14*KEKF*	Three-Terminal Type	(820~561)	17	20	11.5	4.5	0.8	10	5.0	14-2

Metal Oxide Varistor : TVT Series

Thermally Protected Varistor Series



- TVT25*KEKG Type (Box Type)

Two-Terminal Type

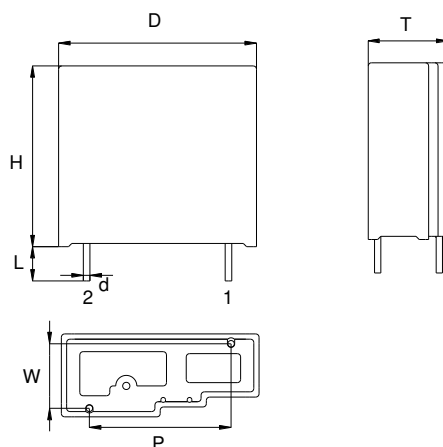

Figure 25-1

(Unit: mm)

Series	Lead Type	Varistor Voltage	D±1	H±1	T±1	L±1	Φd±0.05	P±0.5	W±0.5	Figure
TVT25*KEKG*	Two-Terminal Type	(820~511)	30	28	9.8	4.5	1.0	21.5	7.3	25-1
TVT25*KEKG*	Two-Terminal Type	(561~122)			12.6				9.8	

- TVT25*KFKG Type (Box Type)

Three-Terminal Type

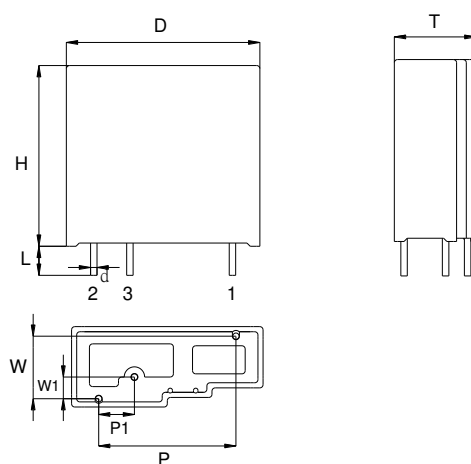

Figure 25-2

(Unit: mm)

Series	Lead Type	Varistor Voltage	D±1	H±1	T±1	L±1	Φd±0.05	P±0.5	P1±0.5	W±0.5	W1±0.5	Figure
TVT25*KFKG*	Three-Terminal Type	(820~511)	30	28	9.8	4.5	1.0	21.5	5.6	7.3	3.3	25-2
TVT25*KFKG*	Three-Terminal Type	(561~122)			12.6					9.8		

Metal Oxide Varistor : TVT Series

Thermally Protected Varistor Series



- TVT25*KEKG*S Type (Box Type)

Two-Terminal Type + Remote Signal Function

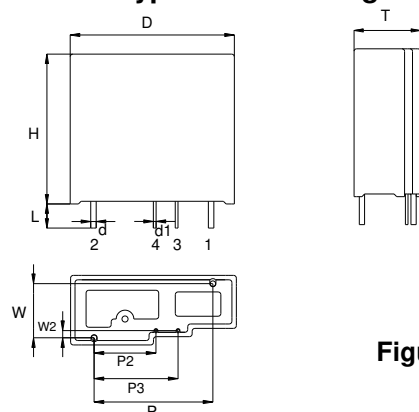

Figure 25-3

(Unit: mm)

Series	Lead Type	Varistor Voltage	D±1	H±1	T±1	L±1	Φd±0.05	Φd1±0.05
TVT25*KEKG*S	Two-Terminal Type + Remote Signal Function	(820~511)	30	28	9.8	4.5	1.0	0.5
TVT25*KEKG*S	Two-Terminal Type + Remote Signal Function	(561~122)			12.6			
Series	Lead Type	Varistor Voltage	P±0.5	P2±0.5	P3±0.5	W±0.5	W2±0.5	Figure
TVT25*KEKG*S	Two-Terminal Type + Remote Signal Function	(820~511)	21.5	11.2	15.2	7.3	1.3	25-3
TVT25*KEKG*S	Two-Terminal Type + Remote Signal Function	(561~122)				9.8		

- TVT25*KFKG*S Type (Box Type)

Three-Terminal Type + Remote Signal Function

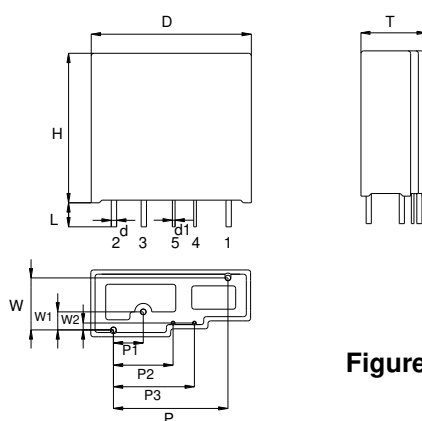

Figure 25-4

(Unit: mm)

Series	Lead Type	Varistor Voltage	D±1	H±1	T±1	L±1	Φd±0.05	Φd1±0.05	P±0.5
TVT25*KFKG*S	Three-Terminal Type + Remote Signal Function	(820~511)	30	28	9.8	4.5	1.0	0.5	21.5
TVT25*KFKG*S	Three-Terminal Type + Remote Signal Function	(561~122)			12.6				
Series	Lead Type	Varistor Voltage	P1±0.5	P2±0.5	P3±0.5	W±0.5	W1±0.5	W2±0.5	Figure
TVT25*KFKG*S	Three-Terminal Type + Remote Signal Function	(820~511)	5.6	11.2	15.2	7.3	3.3	1.3	25-4
TVT25*KFKG*S	Three-Terminal Type + Remote Signal Function	(561~122)				9.8			

Metal Oxide Varistor : TVT Series

Thermally Protected Varistor Series



- TVT25*KEKG Type (Box Type)

Two-Terminal Type

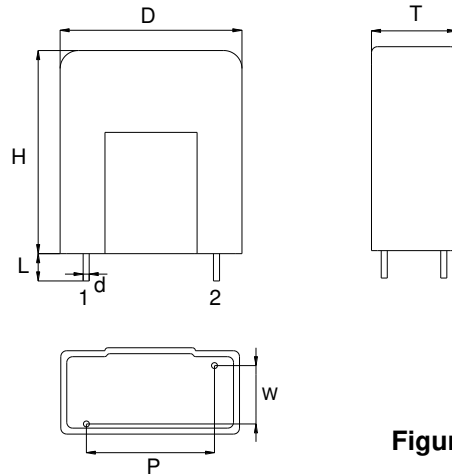

Figure 25-5

(Unit: mm)

Series	Lead Type	Varistor Voltage	D±1	H±1	T±1	L±1	Φd±0.05	P±0.5	W±0.5	Figure
TVT25*KEKG*	Two-Terminal Type	142	30	33.5	15	4.5	1.0	21.5	9.8	25-5

- TVT25*KFKG Type (Box Type)

Three-Terminal Type

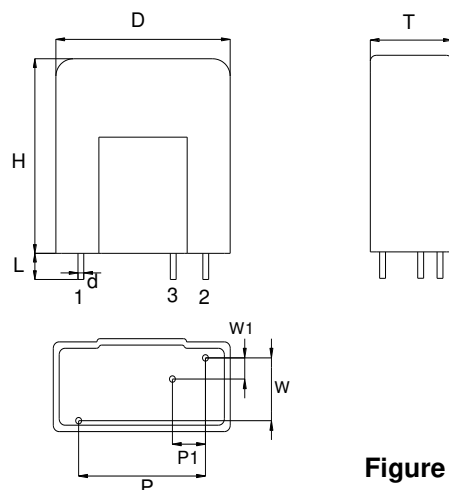

Figure 25-6

(Unit: mm)

Series	Lead Type	Varistor Voltage	D±1	H±1	T±1	L±1	Φd±0.05	P±0.5	P1±0.5	W±0.5	W1±0.5	Figure
TVT25*KEKG*	Two-Terminal Type	142	30	33.5	15	4.5	1.0	21.5	5.6	9.8	3.3	25-6

Metal Oxide Varistor : TVT Series



Thermally Protected Varistor Series

- TVT25*KEKG*S Type (Box Type)

Two-Terminal Type + Remote Signal Function

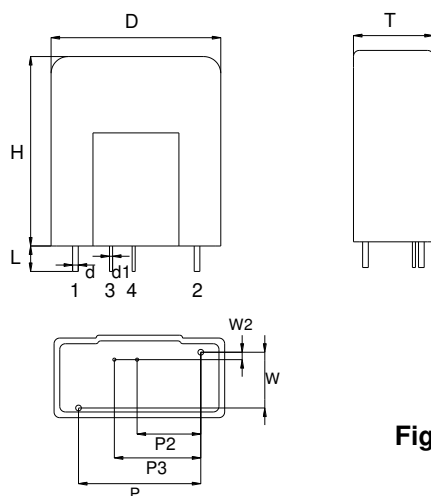

Figure 25-7

(Unit: mm)

Series	Lead Type	Varistor Voltage	D±1	H±1	T±1	L±1	Φd±0.05	Φd1±0.05
TVT25*KEKG*S	Three-Terminal Type + Remote Signal Function	142	30	33.5	15	4.5	1.0	0.5
Series	Lead Type	Varistor Voltage	P±0.5	P2±0.5	P3±0.5	W±0.5	W2±0.5	Figure
TVT25*KEKG*S	Three-Terminal Type + Remote Signal Function	142	21.5	11.2	15.2	9.8	1.3	25-7

- TVT25*KFKG*S Type (Box Type)

Three-Terminal Type + Remote Signal Function

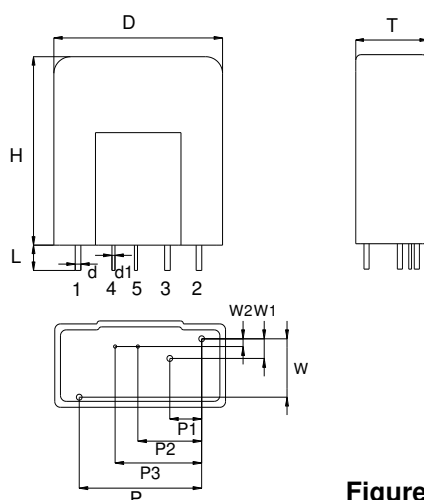

Figure 25-8

(Unit: mm)

Series	Lead Type	Varistor Voltage	D±1	H±1	T±1	L±1	Φd±0.05	Φd1±0.05	P±0.5
TVT25*KFKG*S	Three-Terminal Type + Remote Signal Function	142	30	33.5	15	4.5	1.0	0.5	21.5
Series	Lead Type	Varistor Voltage	P1±0.5	P2±0.5	P3±0.5	W±0.5	W1±0.5	W2±0.5	Figure
TVT25*KFKG*S	Three-Terminal Type + Remote Signal Function	142	5.6	11.2	15.2	9.8	3.3	1.3	25-8

Metal Oxide Varistor : TVT Series



Thermally Protected Varistor Series

■ Electrical Characteristics

14mm Series (Coating Structure)

Part No.	Varistor Voltage (@1mA DC)	Max. Continuous Voltage		Max. Clamping Voltage (8/20 μ s)		Max. Surge Current (8/20 μ s)		Rated Power	Max. Energy (10/1000 μ s)		Dimension	
	V _{1mA}	V _{AC(rms)}	V _{DC}	I _P	V _P	I _{max}	I _n	P	10/1000 μ s	2ms	T _{max}	W \pm 1.0
	(V)	(V)	(V)	(A)	(V)	(A)	(A)	(W)	(J)	(J)	(mm)	
TVT14820	82(74~90)	50	65	50	135	5000	2500	0.6	21	15	8.3	3.1
TVT14101	100(90~110)	60	85	50	165	5000	2500	0.6	24	17	8.3	3.1
TVT14121	120(108~132)	75	100	50	200	5000	2500	0.6	28	20	8.6	3.4
TVT14151	150(135~165)	95	125	50	250	5000	2500	0.6	35	25	8.9	3.7
TVT14201	200(180~220)	130	170	50	340	6000	3000	0.6	77	55	9.1	3.2
TVT14221	220(198~242)	140	180	50	365	6000	3000	0.6	86	62	9.2	3.3
TVT14241	240(216~264)	150	200	50	395	6000	3000	0.6	94	68	9.4	3.5
TVT14271	270(243~297)	175	225	50	455	6000	3000	0.6	110	80	9.6	3.7
TVT14301	300(270~330)	195	250	50	500	6000	3000	0.6	118	85	9.3	3.4
TVT14331	330(297~363)	215	275	50	550	6000	3000	0.6	127	90	9.4	3.5
TVT14361	360(324~396)	230	300	50	595	6000	3000	0.6	137	98	9.6	3.7
TVT14391	390(351~429)	250	320	50	650	6000	3000	0.6	154	110	9.8	3.8
TVT14431	430(387~473)	275	350	50	710	6000	3000	0.6	170	120	9.5	3.6
TVT14471	470(423~517)	300	385	50	775	6000	3000	0.6	192	138	9.6	3.7
TVT14511	510(459~561)	320	410	50	845	6000	3000	0.6	209	150	9.8	3.9
TVT14561	560(504~616)	350	450	50	930	6000	3000	0.6	220	158	10.0	4.1
TVT14621	620(558~682)	395	510	50	1025	6000	3000	0.6	231	165	10.3	4.3
TVT14681	680(612~748)	420	560	50	1120	6000	3000	0.6	242	172	10.6	4.6
TVT14751	750(675~825)	465	615	50	1240	6000	3000	0.6	247	175	10.9	4.9
TVT14781	780(702~858)	485	640	50	1290	6000	3000	0.6	260	180	10.4	4.5
TVT14821	820(738~902)	510	670	50	1355	6000	3000	0.6	270	192	10.5	4.7
TVT14911	910(819~1001)	550	745	50	1500	6000	3000	0.6	280	200	10.9	5.0
TVT14951	950(855~1045)	575	765	50	1570	6000	3000	0.6	290	210	11.0	5.1
TVT14102	1000(900~1100)	625	825	50	1650	6000	3000	0.6	305	218	11.2	5.3
TVT14112	1100(990~1210)	680	895	50	1815	6000	3000	0.6	340	242	11.4	5.6
TVT14122	1200(1080~1320)	750	980	50	2000	6000	3000	0.6	350	260	11.9	6.0

Metal Oxide Varistor : TVT Series



Thermally Protected Varistor Series

20mm Series (Coating Structure)

Part No.	Varistor Voltage (@1mA DC)	Max. Continuous Voltage		Max. Clamping Voltage (8/20 μ s)		Max. Surge Current (8/20 μ s)		Rated Power	Max. Energy W _{max}		Dimension	
	V _{1mA}	V _{AC(rms)}	V _{DC}	I _P	V _P	I _{max}	I _n	P	10/1000 μ s	2ms	T _{max}	W \pm 1.0
	(V)	(V)	(V)	(A)	(V)	(A)	(A)	(W)	(J)	(J)	(mm)	
TVT20820	82(74~90)	50	65	100	135	6500	3000	1.0	38	27	10.7	3.2
TVT20101	100(90~110)	60	85	100	165	6500	3000	1.0	46	33	10.7	3.2
TVT20121	120(108~132)	75	100	100	200	6500	3000	1.0	56	40	10.7	3.2
TVT20151	150(135~165)	95	125	100	250	6500	3000	1.0	70	50	11.0	3.5
TVT20201	200(180~220)	130	170	100	340	10000	5000	1.0	140	100	10.8	3.2
TVT20221	220(198~242)	140	180	100	365	10000	5000	1.0	155	110	10.9	3.3
TVT20241	240(216~264)	150	200	100	395	10000	5000	1.0	170	120	11.1	3.5
TVT20271	270(243~297)	175	225	100	455	10000	5000	1.0	190	135	11.3	3.7
TVT20301	300(270~330)	195	250	100	500	10000	5000	1.0	205	145	11.0	3.4
TVT20331	330(297~363)	215	275	100	550	10000	5000	1.0	215	155	11.1	3.5
TVT20361	360(324~396)	230	300	100	595	10000	5000	1.0	225	160	11.3	3.7
TVT20391	390(351~429)	250	320	100	650	10000	5000	1.0	240	170	11.5	3.8
TVT20431	430(387~473)	275	350	100	710	10000	5000	1.0	270	192	11.2	3.6
TVT20471	470(423~517)	300	385	100	775	10000	5000	1.0	350	250	11.3	3.7
TVT20511	510(459~561)	320	410	100	845	10000	5000	1.0	386	275	11.5	3.9
TVT20561	560(504~616)	350	450	100	930	10000	5000	1.0	400	285	11.7	4.1
TVT20621	620(558~682)	395	510	100	1025	10000	5000	1.0	425	305	12.0	4.3
TVT20681	680(612~748)	420	560	100	1120	10000	5000	1.0	455	325	12.3	4.6
TVT20751	750(675~825)	465	615	100	1240	10000	5000	1.0	509	365	12.6	4.9
TVT20781	780(702~858)	485	640	100	1290	10000	5000	1.0	515	350	12.1	4.5
TVT20821	820(738~902)	510	670	100	1355	10000	5000	1.0	475	340	12.2	4.7
TVT20911	910(819~1001)	550	745	100	1500	10000	5000	1.0	509	365	12.6	5.0
TVT20951	950(855~1045)	575	765	100	1570	10000	5000	1.0	530	380	12.7	5.1
TVT20102	1000(900~1100)	625	825	100	1650	10000	5000	1.0	560	400	12.9	5.3
TVT20112	1100(990~1210)	680	895	100	1815	10000	5000	1.0	610	435	13.2	5.6
TVT20122	1200(1080~1320)	750	980	100	2000	10000	5000	1.0	620	450	13.6	6.0
TVT20142	1400(1260~1540)	820	1140	100	2300	6500	3000	1.0	480	345	14.6	6.8
TVT20162	1600(1440~1760)	910	1300	100	2630	6500	3000	1.0	550	395	15.1	7.5
TVT20182	1800(1620~1980)	1000	1462	100	2950	6500	3000	1.0	620	445	15.9	8.2

Metal Oxide Varistor : TVT Series



Thermally Protected Varistor Series

25mm Series (Coating Structure)

Part No.	Varistor Voltage (@1mA DC)	Max. Continuous Voltage		Max. Clamping Voltage (8/20 μ s)		Max. Surge Current (8/20 μ s)		Rated Power	Max. Energy Wmax		Dimension	
	V _{1mA}	V _{AC(rms)}	V _{DC}	I _P	V _P	I _{max}	I _n	T _{max}	10/1000 μ s	2ms	Tmax	W \pm 1.0
	(V)	(V)	(V)	(A)	(V)	(A)	(A)	(W)	(J)	(J)	(mm)	
TVT25201	200(180~220)	130	170	150	340	20000	10000	1.0	210	150	11.3	3.7
TVT25221	220(198~242)	140	180	150	365	20000	10000	1.0	230	165	11.4	3.8
TVT25241	240(216~264)	150	200	150	395	20000	10000	1.0	255	180	11.5	4.0
TVT25271	270(243~297)	175	225	150	455	20000	10000	1.0	285	205	11.8	4.2
TVT25301	300(270~330)	195	250	150	500	20000	10000	1.0	310	225	12.0	3.9
TVT25331	330(297~363)	215	275	150	550	20000	10000	1.0	325	235	12.3	4.0
TVT25361	360(324~396)	230	300	150	595	20000	10000	1.0	340	240	12.5	4.2
TVT25391	390(351~429)	250	320	150	650	20000	10000	1.0	360	250	12.6	4.4
TVT25431	430(387~473)	275	350	150	710	20000	10000	1.0	440	310	12.7	4.3
TVT25471	470(423~517)	300	385	150	775	20000	10000	1.0	490	345	12.7	4.5
TVT25511	510(459~561)	320	410	150	845	20000	10000	1.0	530	370	12.9	4.7
TVT25561	560(504~616)	350	450	150	930	20000	10000	1.0	560	390	13.1	4.9
TVT25621	620(558~682)	395	510	150	1025	20000	10000	1.0	590	410	13.5	5.2
TVT25681	680(612~748)	420	560	150	1120	20000	10000	1.0	620	430	13.6	5.5
TVT25751	750(675~825)	465	615	150	1240	20000	10000	1.0	630	440	13.6	5.8
TVT25781	780(702~858)	485	640	150	1290	20000	10000	1.0	675	455	13.7	5.0
TVT25821	820(738~902)	510	670	150	1355	20000	10000	1.0	390	480	13.7	5.2
TVT25911	910(819~1001)	550	745	150	1500	20000	10000	1.0	715	500	13.9	5.5
TVT25951	950(855~1045)	575	765	150	1570	20000	10000	1.0	740	520	14.2	5.6
TVT25102	1000(900~1100)	625	825	150	1650	20000	10000	1.0	770	550	14.3	5.8
TVT25112	1100(990~1210)	680	895	150	1815	20000	10000	1.0	840	600	14.8	6.1
TVT25122	1200(1080~1320)	750	980	150	2000	20000	10000	1.0	910	650	15.3	6.5

Metal Oxide Varistor : TVT Series



Thermally Protected Varistor Series

14mm Series (Potting Structure)

Part No.	Varistor Voltage (@ 1mA DC)	Max. Continuous Voltage		Max. Clamping Voltage (8/20μs)		Max. Surge Current (8/20μs)		Rated Power	Max. Energy Wmax	
	V _{1mA}	V _{AC(rms)}	V _{DC}	I _P	V _P	I _{max}	I _n	P	10/1000μs	2ms
	(V)	(V)	(V)	(A)	(V)	(A)	(A)	(W)	(J)	(J)
TVT14820	82(74~90)	50	65	50	135	5000	2500	0.6	21	15
TVT14101	100(90~110)	60	85	50	165	5000	2500	0.6	26	18
TVT14121	120(108~132)	75	100	50	200	5000	2500	0.6	31	22
TVT14151	150(135~165)	95	125	50	250	5000	2500	0.6	39	27
TVT14201	200(180~220)	130	170	50	340	6000	3000	0.6	52	36
TVT14221	220(198~242)	140	180	50	365	6000	3000	0.6	58	41
TVT14241	240(216~264)	150	200	50	395	6000	3000	0.6	64	45
TVT14271	270(243~297)	175	225	50	455	6000	3000	0.6	67	47
TVT14301	300(270~330)	195	250	50	500	6000	3000	0.6	70	49
TVT14331	330(297~363)	215	275	50	550	6000	3000	0.6	72	50
TVT14361	360(324~396)	230	300	50	595	6000	3000	0.6	76	53
TVT14391	390(351~429)	250	320	50	650	6000	3000	0.6	82	57
TVT14431	430(387~473)	275	350	50	710	6000	3000	0.6	93	65
TVT14471	470(423~517)	300	385	50	775	6000	3000	0.6	99	69
TVT14511	510(459~561)	320	410	50	845	6000	3000	0.6	107	75
TVT14561	560(504~616)	350	450	50	930	6000	3000	0.6	113	79

Note: Agency approval is pending

Metal Oxide Varistor : TVT Series



Thermally Protected Varistor Series

25mm Series (Potting Structure)

Part No.	Varistor Voltage (@1mA DC)	Max. Continuous Voltage		Max. Clamping Voltage (8/20 μ s)		Max. Surge Current (8/20 μ s)		Rated Power	Max. Energy Wmax	
	V _{1mA}	V _{AC(rms)}	V _{DC}	I _P	V _P	I _{max}	I _n	P	10/1000 μ s	2ms
	(V)	(V)	(V)	(A)	(V)	(A)	(A)	(W)	(J)	(J)
TVT25820	82(74~90)	50	65	150	135	20000	10000	1.0	89	62
TVT25101	100(90~110)	60	85	150	165	20000	10000	1.0	112	78
TVT25121	120(108~132)	75	100	150	200	20000	10000	1.0	135	95
TVT25201	200(180~220)	130	170	150	340	25000	10000	1.0	235	165
TVT25221	220(198~242)	140	180	150	365	25000	10000	1.0	260	182
TVT25241	240(216~264)	150	200	150	395	25000	10000	1.0	285	200
TVT25271	270(243~297)	175	225	150	455	25000	10000	1.0	320	224
TVT25301	300(270~330)	195	250	150	500	25000	10000	1.0	350	245
TVT25331	330(297~363)	215	275	150	550	25000	10000	1.0	365	256
TVT25361	360(324~396)	230	300	150	595	25000	10000	1.0	380	266
TVT25391	390(351~429)	250	320	150	650	25000	10000	1.0	405	284
TVT25431	430(387~473)	275	350	150	710	25000	10000	1.0	495	347
TVT25471	470(423~517)	300	385	150	775	25000	10000	1.0	550	385
TVT25511	510(459~561)	320	410	150	845	25000	10000	1.0	595	417
TVT25561	560(504~616)	350	450	150	930	25000	10000	1.0	630	441
TVT25621	620(558~682)	395	510	150	1025	25000	10000	1.0	660	462
TVT25681	680(612~748)	420	560	150	1120	25000	10000	1.0	695	487
TVT25751	750(675~825)	465	615	150	1240	25000	10000	1.0	710	497
TVT25781	780(702~858)	485	640	150	1290	25000	10000	1.0	760	532
TVT25821	820(738~902)	510	670	150	1355	25000	10000	1.0	775	543
TVT25911	910(819~1001)	550	745	150	1500	25000	10000	1.0	800	560
TVT25951	950(855~1045)	575	765	150	1570	25000	10000	1.0	830	581
TVT25102	1000(900~1100)	625	825	150	1650	25000	10000	1.0	865	606
TVT25112	1100(990~1210)	680	895	150	1815	25000	10000	1.0	940	658
TVT25122	1200(1080~1320)	750	980	150	2000	25000	10000	1.0	1020	714
TVT25142	1400(1260~1540)	820	1140	150	2300	20000	10000	1.0	1190	833

Note: Agency approval is pending

Metal Oxide Varistor : TVT Series

Thermally Protected Varistor Series



■ Safety Approvals

Certified Model No.	Agency				
	UL1449 4 th & cUL	IEC 61051-1 IEC 61051-2 IEC 61051-2-2	IEC60950-1 2 nd Annex Q	GB/T 10193-1997 GB/T 10194-1997	GB 4943.1-2022 IEC61051-2:1991 +Amd1:2009
	E314979	J 50179371		CQC13001104230	
TVT14820-□	√				
TVT14101-□	√				
TVT14121-□	√				
TVT14151-□	√				
TVT14201-□	√	√	√	√	
TVT14221-□	√	√	√	√	
TVT14241-□	√	√	√	√	
TVT14271-□	√	√	√	√	
TVT14301-□	√	√	√	√	
TVT14331-□	√	√	√	√	
TVT14361-□	√	√	√	√	
TVT14391-□	√	√	√	√	
TVT14431-□	√	√	√	√	√
TVT14471-□	√	√	√	√	√
TVT14511-□	√	√	√	√	√
TVT14561-□	√	√	√	√	√
TVT14621-□	√	√	√	√	√
TVT14681-□	√	√	√	√	√
TVT14751-□	√	√	√	√	√
TVT14781-□	√	√	√	√	√
TVT14821-□	√	√	√	√	√
TVT14911-□	√	√	√	√	√
TVT14951-□	√	√	√	√	√
TVT14102-□	√	√	√	√	√
TVT14112-□	√	√	√	√	√
TVT14122-□	√	√	√	√	√



□ is the code for Two-Terminal type or Three-Terminal type.

Metal Oxide Varistor : TVT Series

Thermally Protected Varistor Series



■ Safety Approvals

Certified Model No.	Agency				
					
	UL1449 4 th & cUL:	IEC 61051-1 IEC 61051-2 IEC 61051-2-2	IEC60950-1 2 nd Annex Q	GB/T 10193-1997 GB/T 10194-1997	GB 4943.1-2022 IEC61051-2:1991 +Amd1:2009
	E314979	J 50179389		CQC13001104230	
TVT20820-□	√				
TVT20101-□	√				
TVT20121-□	√				
TVT20151-□	√				
TVT20201-□	√	√	√	√	
TVT20221-□	√	√	√	√	
TVT20241-□	√	√	√	√	
TVT20271-□	√	√	√	√	
TVT20301-□	√	√	√	√	
TVT20331-□	√	√	√	√	
TVT20361-□	√	√	√	√	
TVT20391-□	√	√	√	√	
TVT20431-□	√	√	√	√	√
TVT20471-□	√	√	√	√	√
TVT20511-□	√	√	√	√	√
TVT20561-□	√	√	√	√	√
TVT20621-□	√	√	√	√	√
TVT20681-□	√	√	√	√	√
TVT20751-□	√	√	√	√	√
TVT20781-□	√	√	√	√	√
TVT20821-□	√	√	√	√	√
TVT20911-□	√	√	√	√	√
TVT20951-□	√	√	√	√	√
TVT20102-□	√	√	√	√	√
TVT20112-□	√	√	√	√	√
TVT20122-□	√	√	√	√	√
TVT20142-□	√	√	√	√	√
TVT20162-□	√	√	√	√	√
TVT20182-□	√	√	√	√	√



□ is the code for Two-Terminal type or Three-Terminal type.

Metal Oxide Varistor : TVT Series

Thermally Protected Varistor Series



■ Safety Approvals

Certified Model No.	Agency	
		
	UL1449 4 th & cUL:	IEC 61051-1 IEC 61051-2 IEC 61051-2-2
	E314979	J 50226398
TVT25201-□	√	√
TVT25221-□	√	√
TVT25241-□	√	√
TVT25271-□	√	√
TVT25301-□	√	√
TVT25331-□	√	√
TVT25361-□	√	√
TVT25391-□	√	√
TVT25431-□	√	√
TVT25471-□	√	√
TVT25511-□	√	√
TVT25561-□	√	√
TVT25621-□	√	√
TVT25681-□	√	√
TVT25751-□	√	√
TVT25781-□	√	√
TVT25821-□	√	√
TVT25911-□	√	√
TVT25951-□	√	√
TVT25102-□	√	√
TVT25112-□	√	√
TVT25122-□	√	√

□ is the code for Two-Terminal type or Three-Terminal type.

Metal Oxide Varistor : TVT Series



Thermally Protected Varistor Series

■ Power Derating Curve

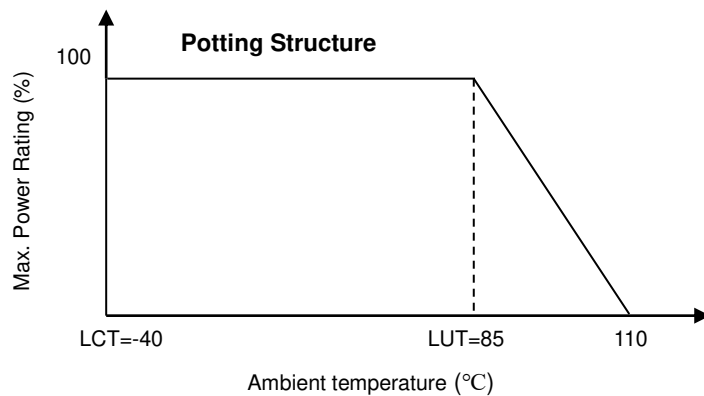
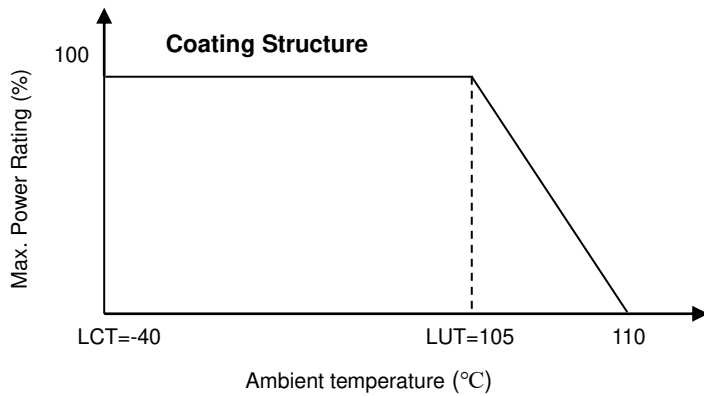

■ Surge Current Standard Waveform

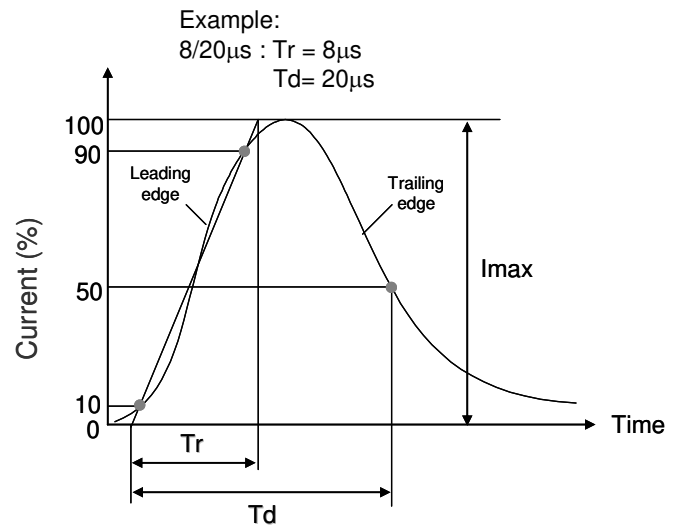

■ Lead Configuration

● Coating Structure

Two-Terminal Type

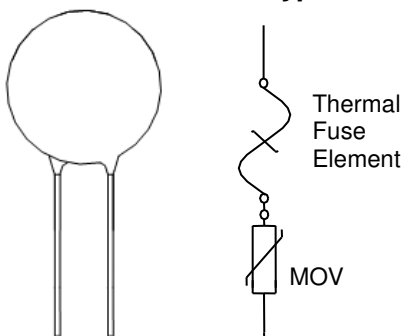

Three-Terminal Type

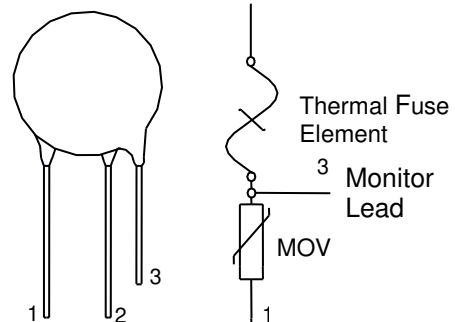

● Potting Structure-TVT14

Two-Terminal Type

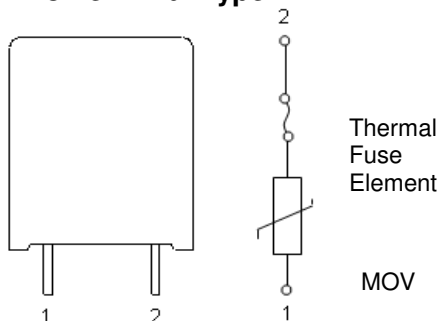

Three-Terminal Type

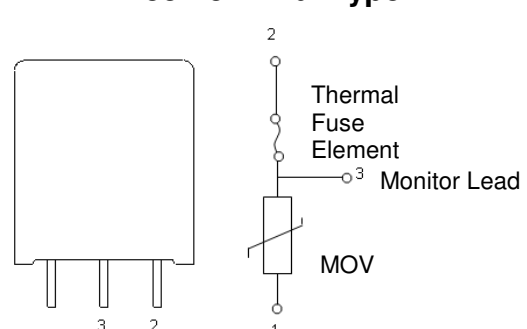

Metal Oxide Varistor : TVT Series



Thermally Protected Varistor Series

● Potting Structure -TVT25

Two-Terminal Type (Box Type)

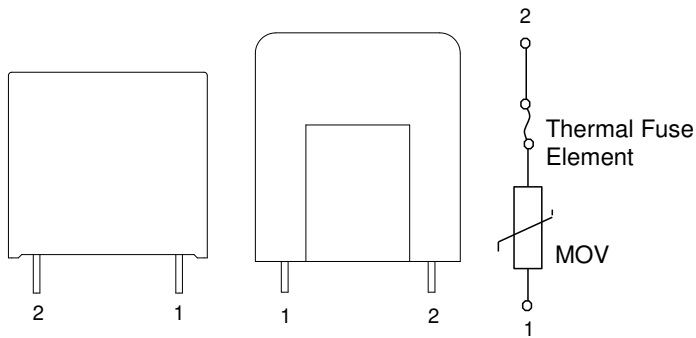

Three-Terminal Type (Box Type)

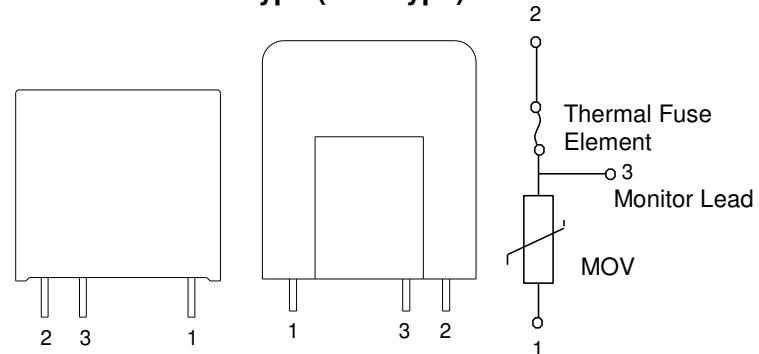

Two-Terminal Type + Remote Signal Function (Box Type)

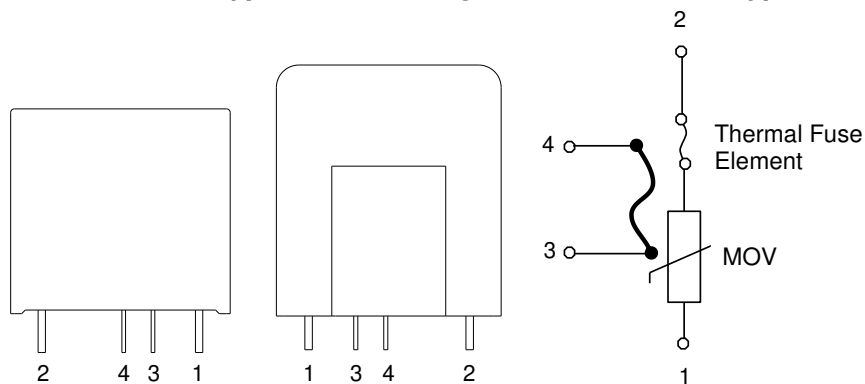

Three-Terminal Type + Remote Signal Function (Box Type)

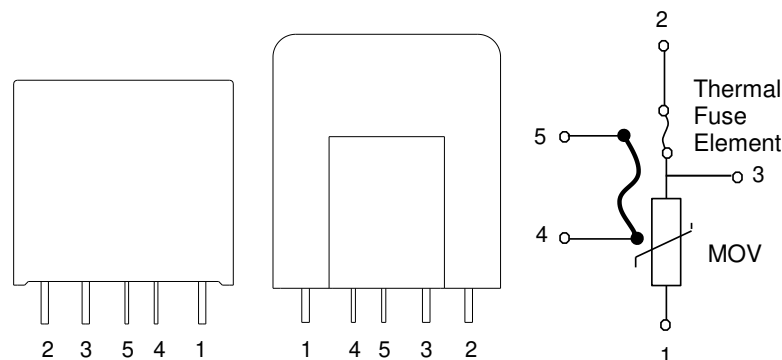

■ Typical Application Circuit

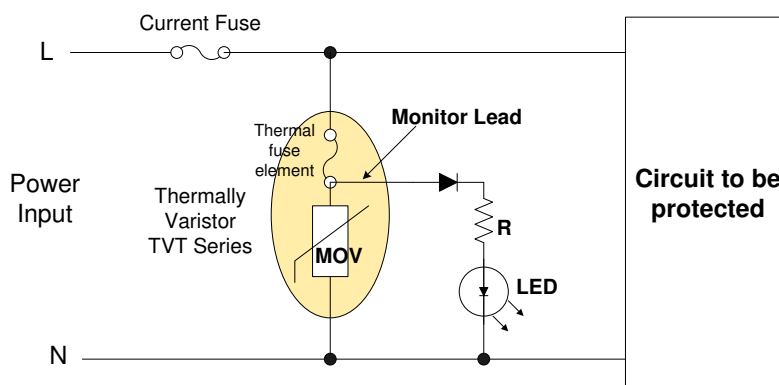

Metal Oxide Varistor : TVT Series



Thermally Protected Varistor Series

Max. Surge Current Derating Curves (Coating Structure)

TVT14820~TVT14151

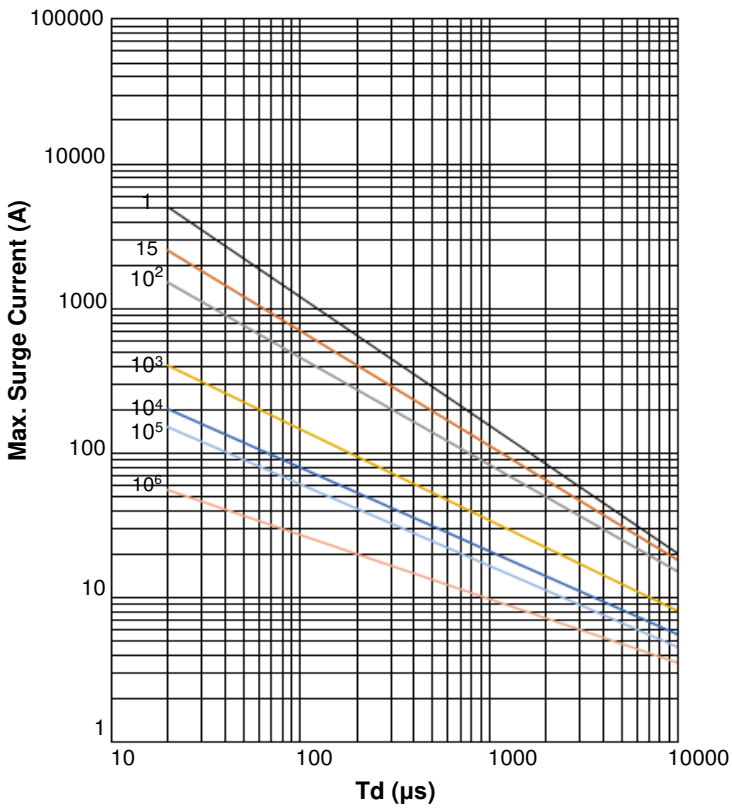

TVT14201~14122

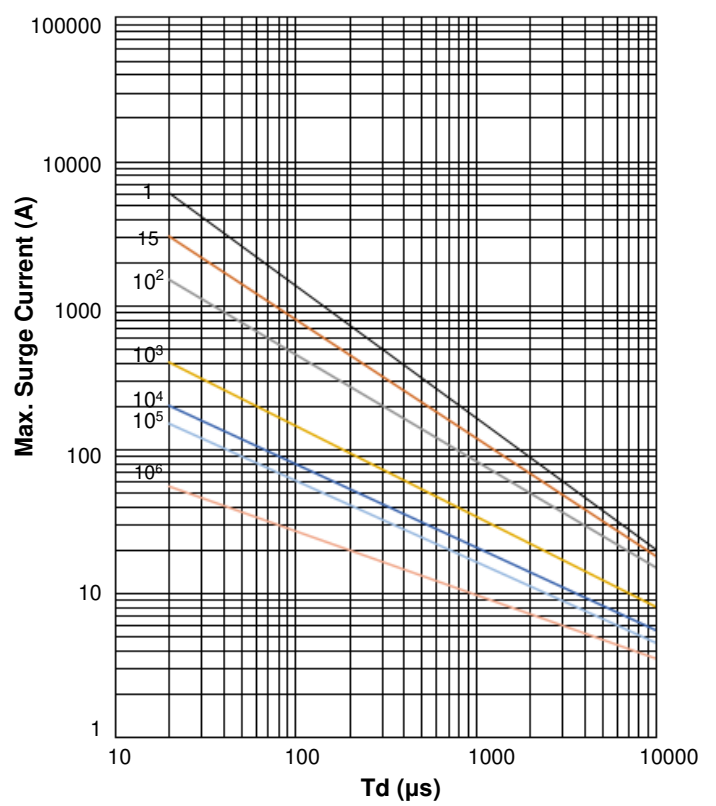

TVT20820~151 & 20142~20182

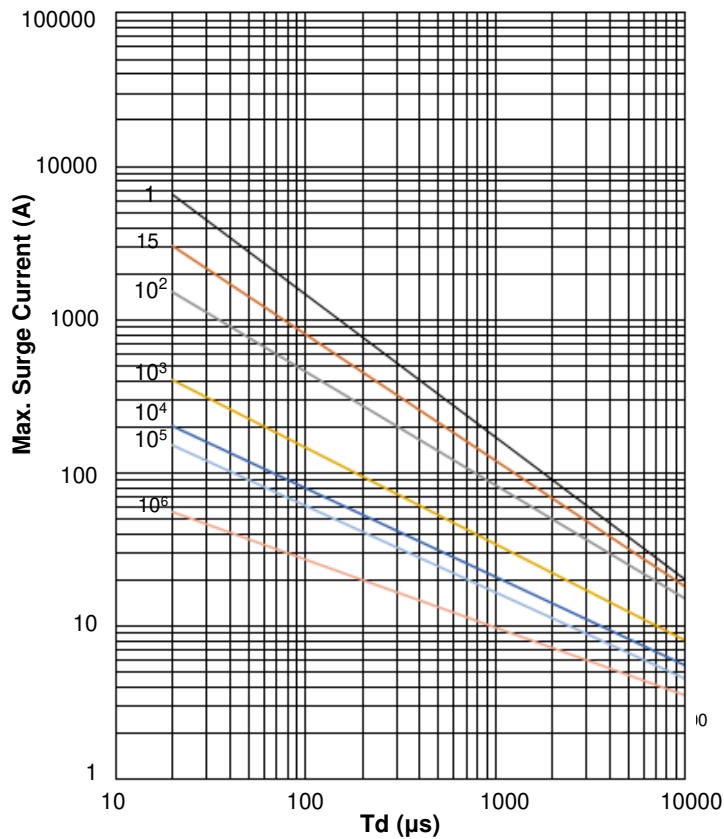

TVT20201~20122

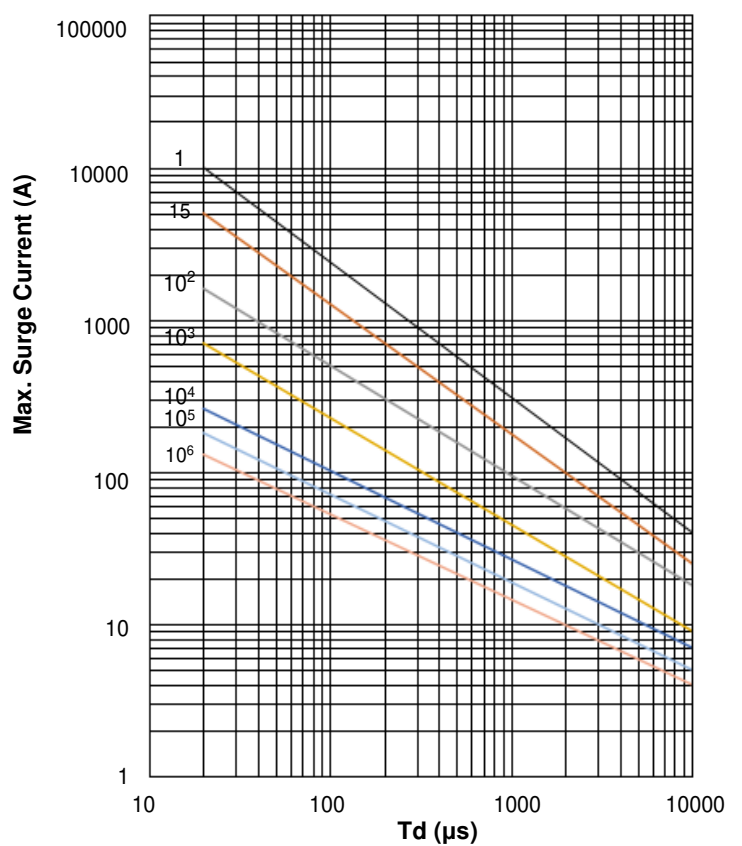

Metal Oxide Varistor : TVT Series



Thermally Protected Varistor Series

■ Max. Surge Current Derating Curves (Coating Structure)

TVT25201~25122

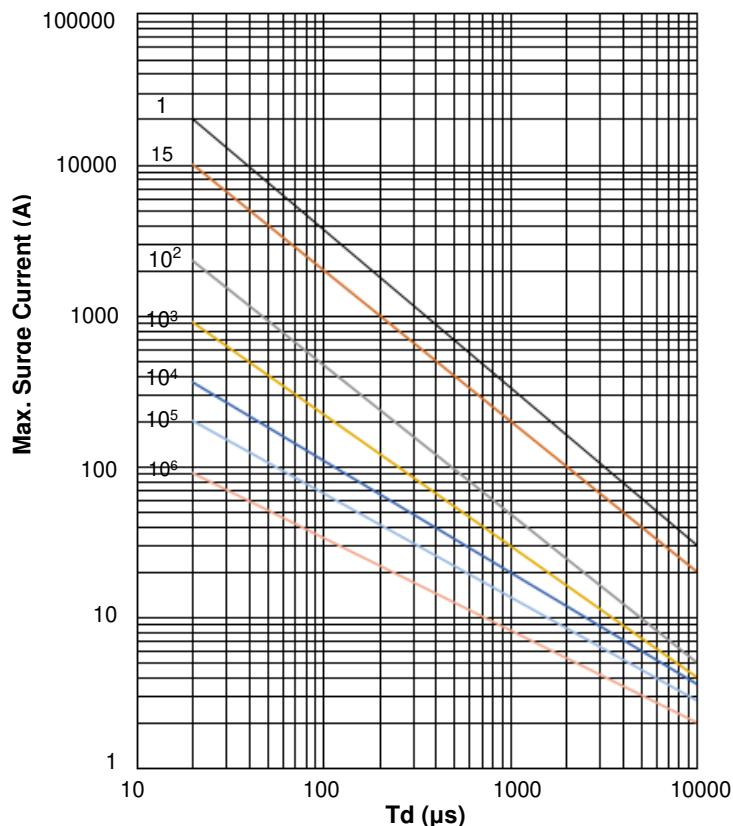

■ Max. Surge Current Derating Curves (Potting Structure)

TVT14820 ~ TVT14151

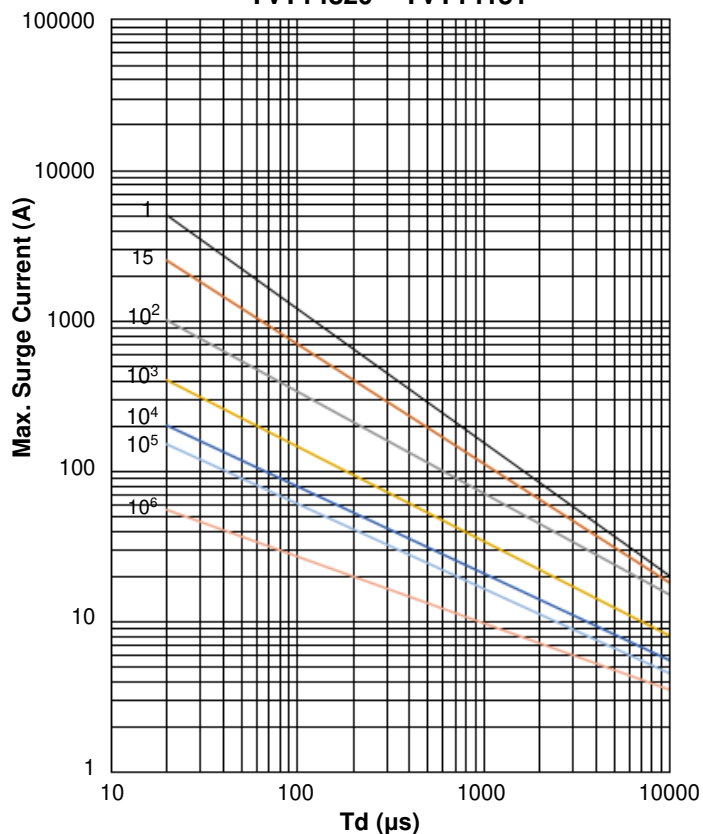

TVT14201 ~ TVT14561

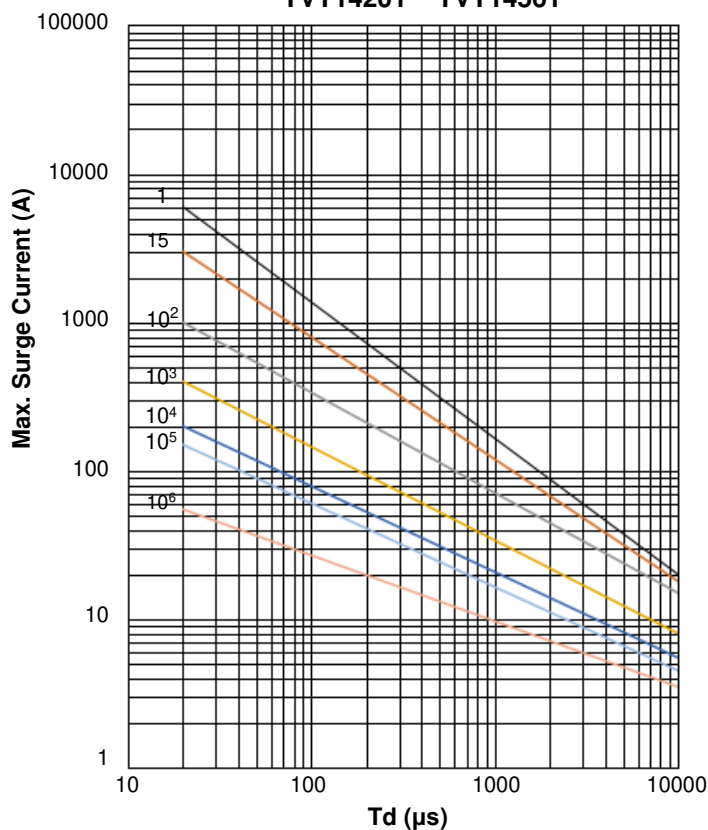

Metal Oxide Varistor : TVT Series



Thermally Protected Varistor Series

Max. Surge Current Derating Curves (Potting Structure)

TVT25820~TVT25121, 25142

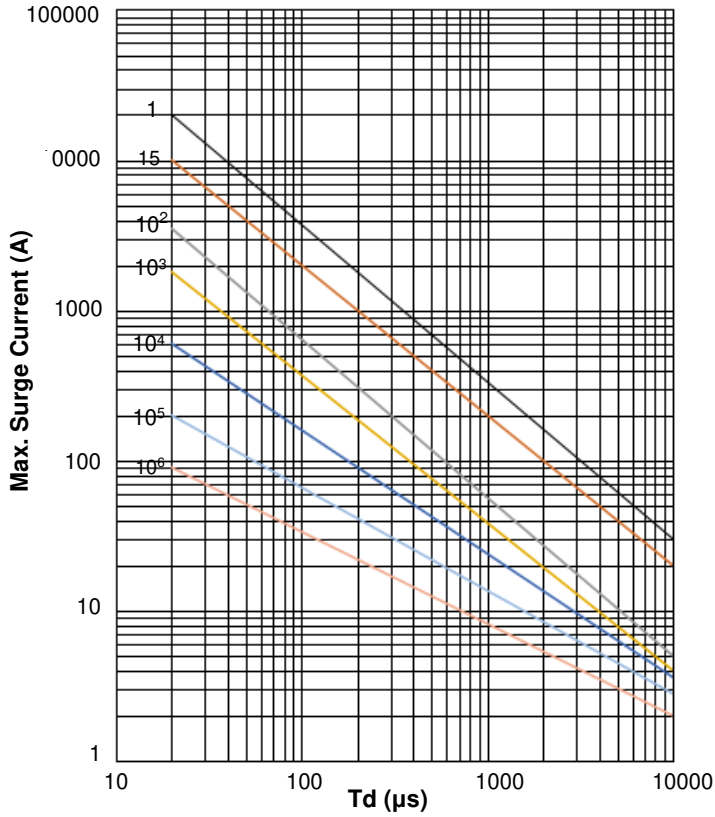

TVT25201~TVT25122

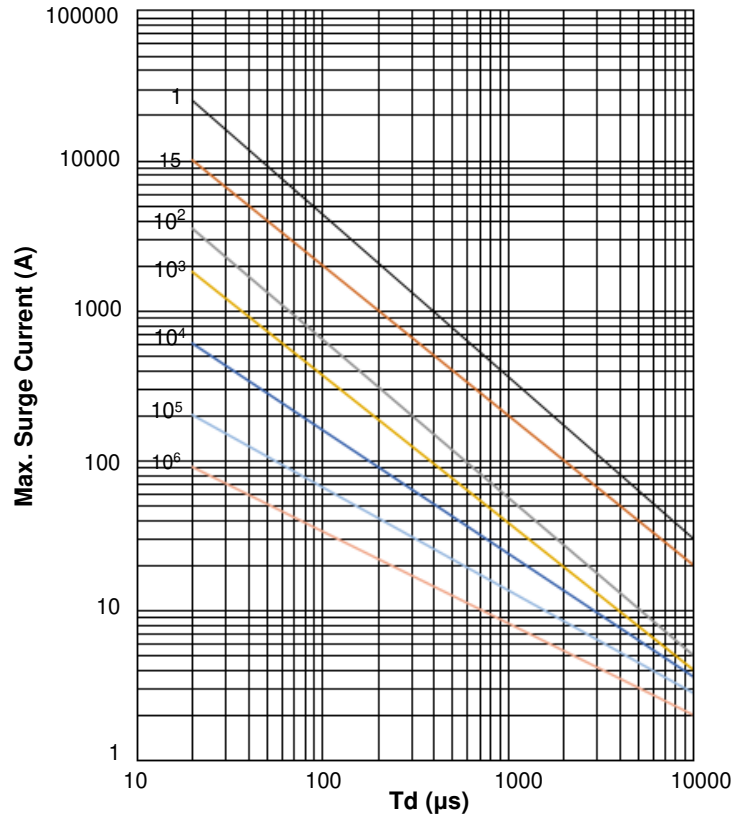

Max. Leakage Current and Max. Clamping Voltage Curves

Max. Leakage Current and Max. Clamping Voltage Curves (TVT14820 ~ TVT14122)

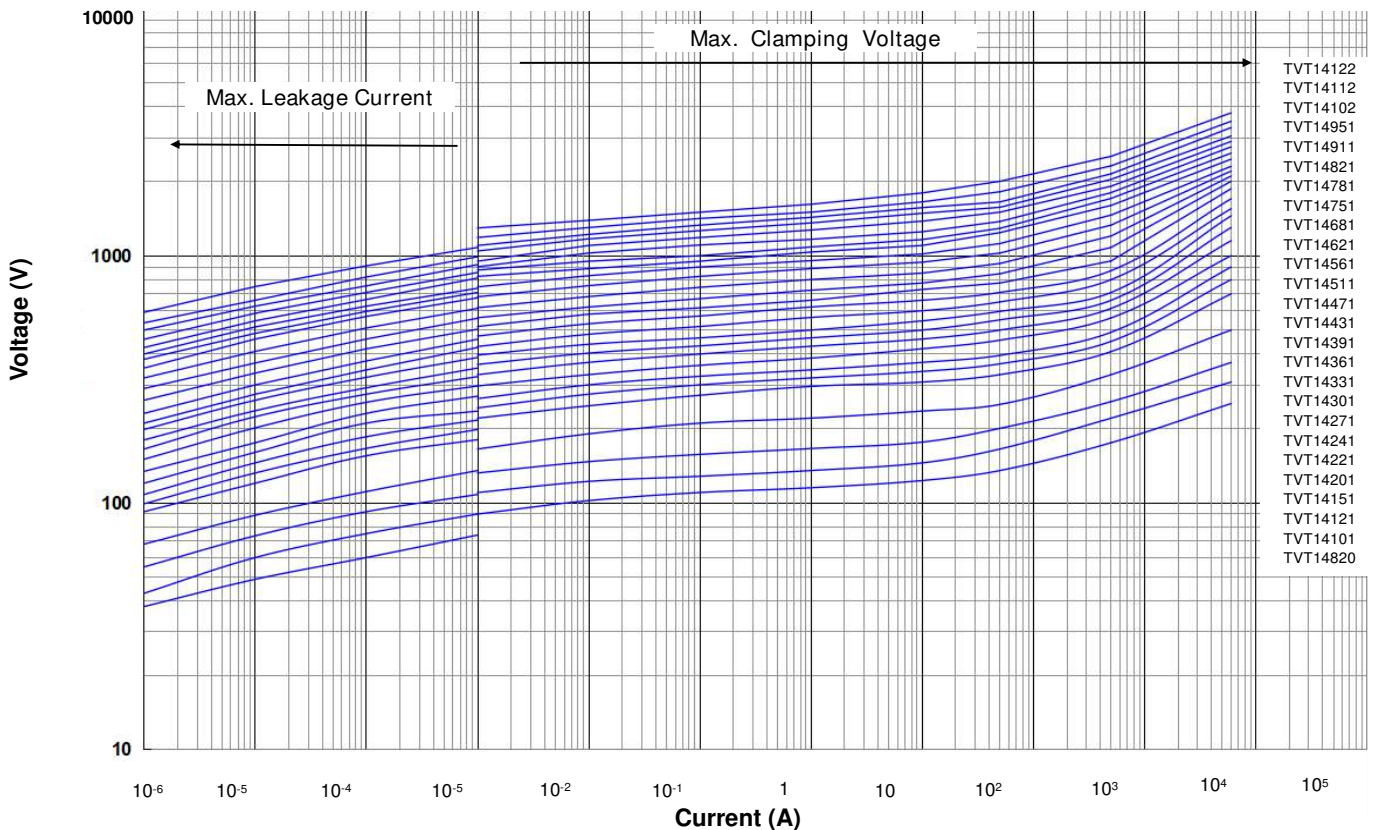

Metal Oxide Varistor : TVT Series



Thermally Protected Varistor Series

Max. Leakage Current and Max. Clamping Voltage Curves

Max. Leakage Current and Max. Clamping Voltage Curves (TVT20820 ~ TVT20182) Coating Structure

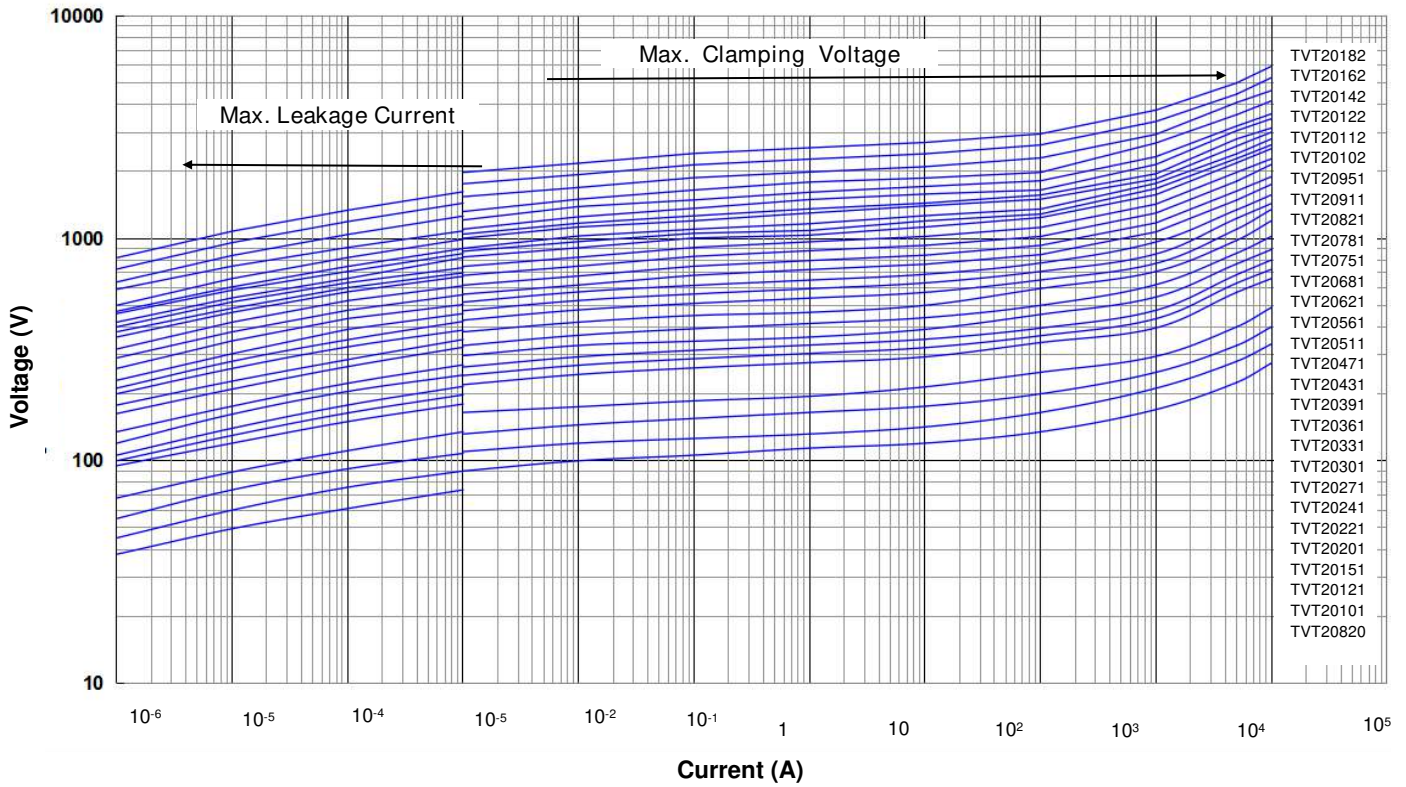

Max. Leakage Current and Max. Clamping Voltage Curves (TVT25820 ~ TVT25122) Coating Structure

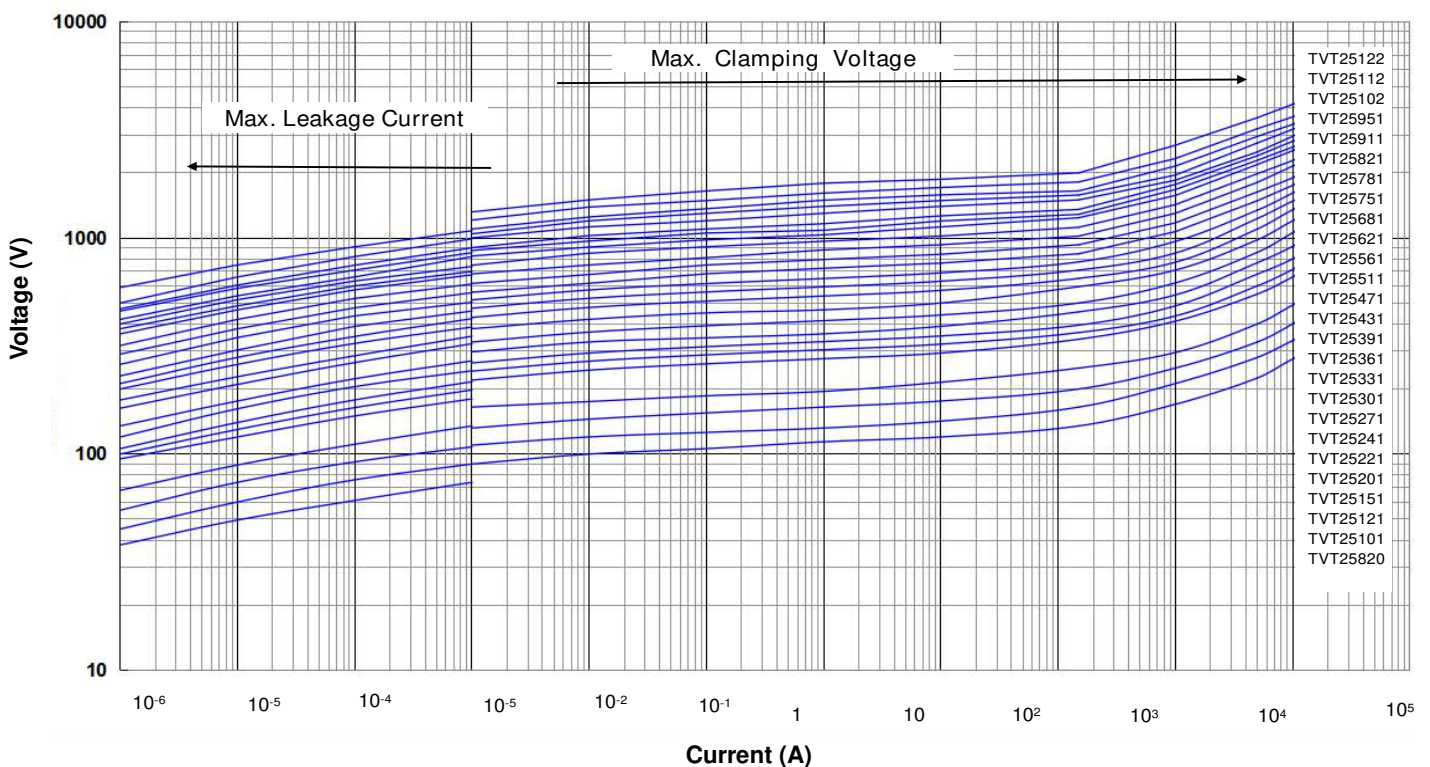

Metal Oxide Varistor : TVT Series



Thermally Protected Varistor Series

■ Max. Leakage Current and Max. Clamping Voltage Curves

Max. Leakage Current and Max. Clamping Voltage Curves (TVT14820 ~ TVT14561) Potting Structure

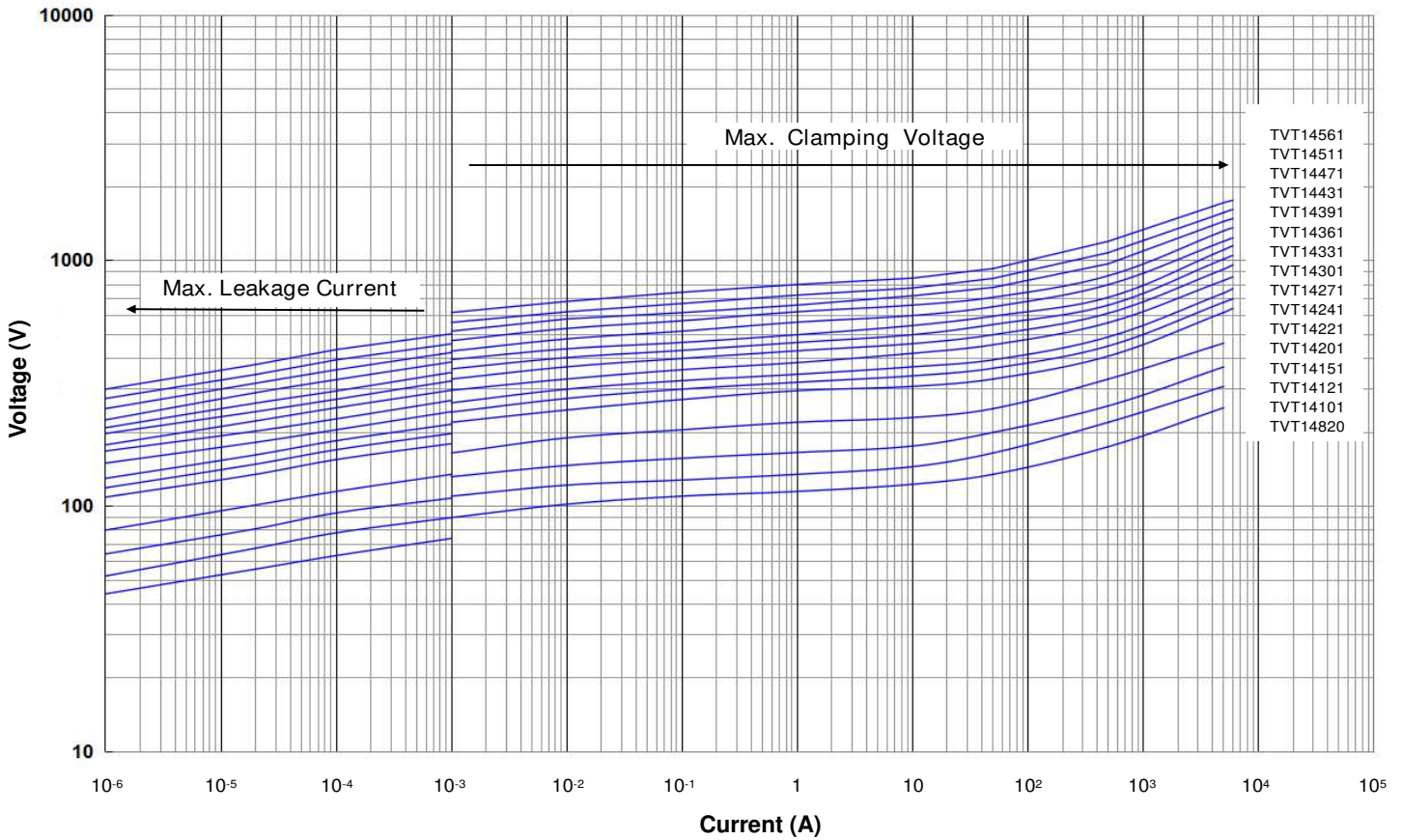

Max. Leakage Current and Max. Clamping Voltage Curves (TVT25820 ~ TVT25142) Potting Structure

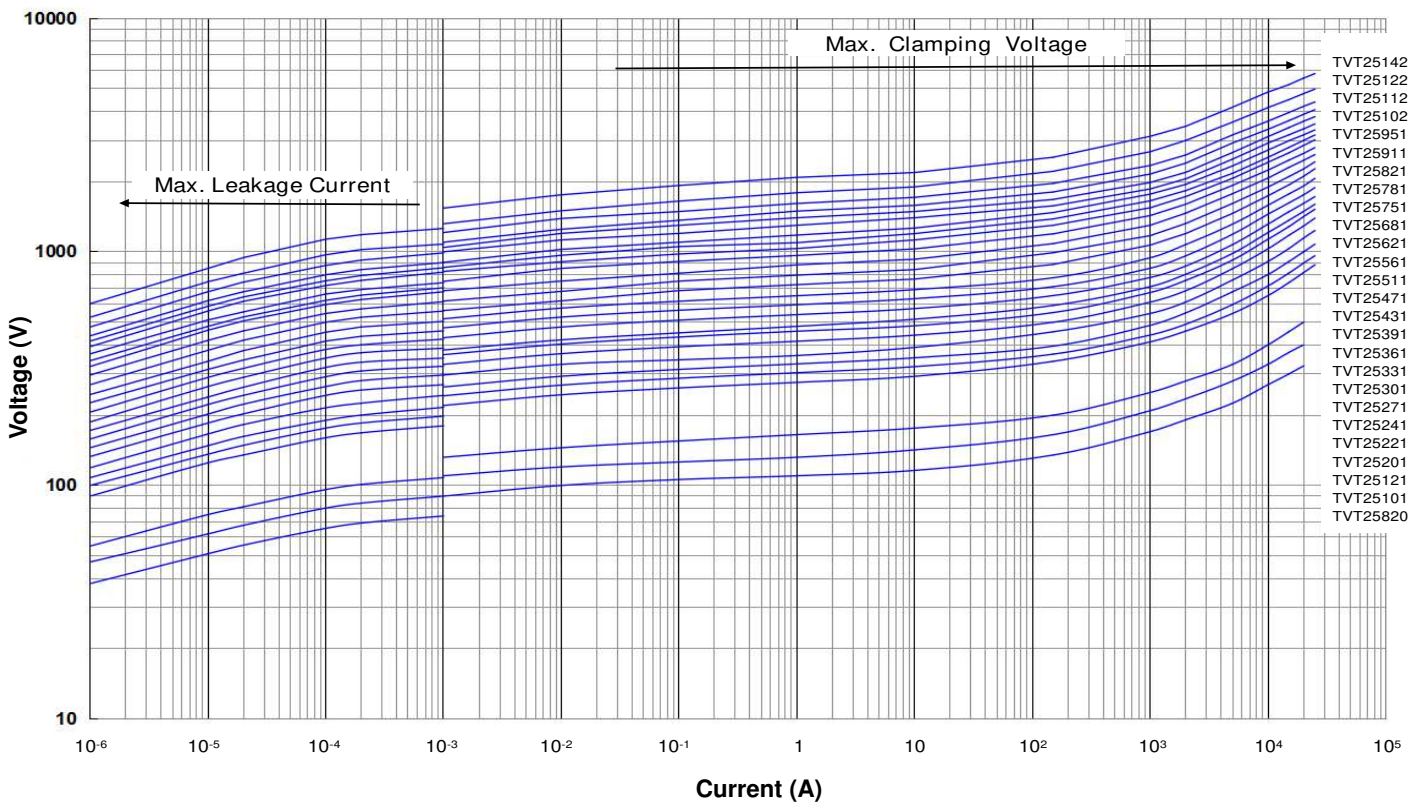

Metal Oxide Varistor : TVT Series



Thermally Protected Varistor Series

Soldering Recommendation

- Wave Soldering Profile

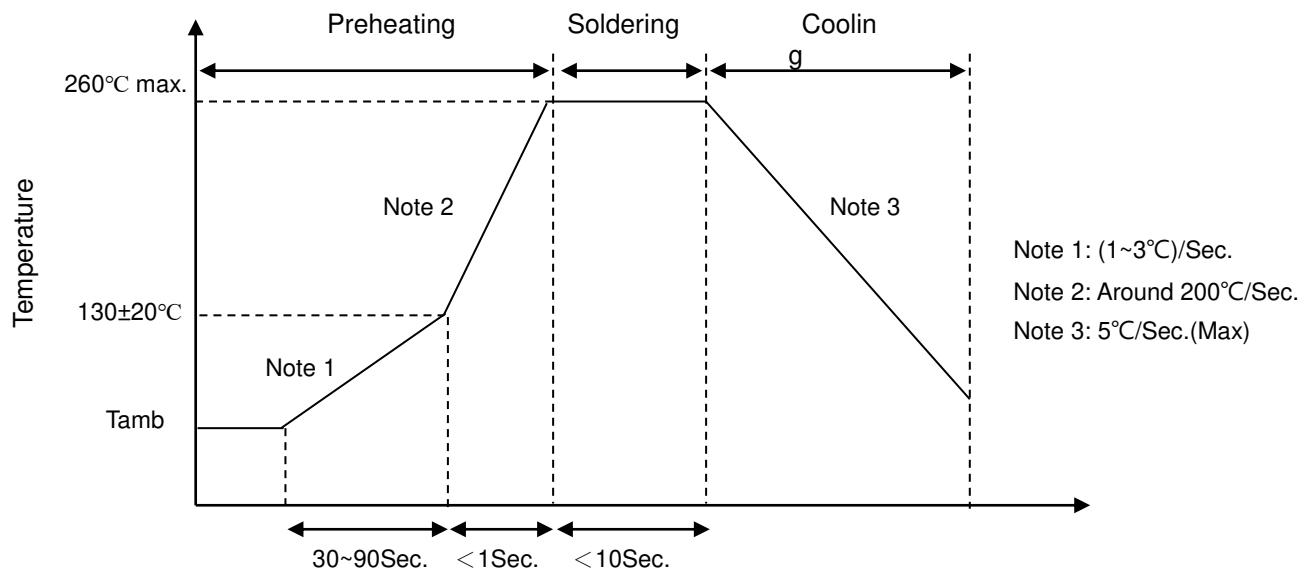

- Recommended Reworking Conditions With Soldering Iron

Item	Conditions
Temperature of Soldering Iron-tip	360°C (max.)
Soldering Time	3 sec (max.)
Distance from Varistor	2 mm (min.)

Metal Oxide Varistor : TVT Series



Thermally Protected Varistor Series

■ Reliability

Item	Standard	Test Conditions / Methods	Specifications															
Tensile Strength of Terminals	IEC61051-1 (IEC60068-2-21)	Gradually apply the specified force and keep the unit fixed for 10±1 sec. Terminal diameter (mm) Terminal cross-sectional area (mm ²) Force (Kg) 0.5<d≤0.8 0.2<S≤0.5 1.0 0.8<d≤1.25 0.5<S≤1.2 2.0 1.25<d 1.2<S 4.0	$ \Delta V_{1mA}/V_{1mA} \leq 5\%$ No visible damage															
Bending Strength of Terminals	IEC61051-1 (IEC 60068-2-21)	Hold specimen and apply the force specified below to each lead. Bend the specimen to 90°, and then return to the original position. Repeat the procedure in the opposite direction. Terminal diameter (mm) Terminal cross-sectional area (mm ²) Force (Kg) 0.5<d≤0.8 0.2<S≤0.5 0.5 0.8<d≤1.25 0.5<S≤1.2 1.0 1.25<d 1.2<S 2.0	$ \Delta V_{1mA}/V_{1mA} \leq 5\%$ No visible damage															
Vibration	IEC61051-1 (IEC 60068-2-6)	Frequency range: 10 ~ 55 Hz Amplitude: 0.75mm or 98 m/s ² Direction: 3 mutually perpendicular directions, 2 hrs each.	$ \Delta V_{1mA}/V_{1mA} \leq 5\%$ No visible damage															
Solderability	IEC61051-1	245±3°C , 3±0.3 sec	At least 95% of terminal electrode is covered by new solder															
Resistance to Soldering Heat	IEC61051-1	260±3°C , 10±1 sec	$ \Delta V_{1mA}/V_{1mA} \leq 5\%$ No visible damage															
High Temperature Storage	IEC 60068-2-2	110±5°C x 1000± 24 hrs	$ \Delta V_{1mA}/V_{1mA} \leq 5\%$ No visible damage															
Damp Heat, Steady State	IEC61051-1 (IEC60068-2-78)	a. 40±2°C, 90 ~ 95 % RH, 1344 hrs b. 40±2°C, 90 ~ 95 % RH, at 10%Vdc, 1344 hrs	$ \Delta V_{1mA}/V_{1mA} \leq 10\%$ No visible damage Insulation Resistance ≥ 100MΩ															
Rapid Change of Temperature	IEC61051-1 (IEC60068-2-14)	The conditions shown below shall be repeated 5 cycles <table border="1"> <thead> <tr> <th>Step</th> <th>Temperature (°C)</th> <th>Period (minutes)</th> </tr> </thead> <tbody> <tr> <td>1</td> <td>-40±3</td> <td>30±3</td> </tr> <tr> <td>2</td> <td>Room temperature</td> <td>5±3</td> </tr> <tr> <td>3</td> <td>85±2</td> <td>30±3</td> </tr> <tr> <td>4</td> <td>Room temperature</td> <td>5±3</td> </tr> </tbody> </table>	Step	Temperature (°C)	Period (minutes)	1	-40±3	30±3	2	Room temperature	5±3	3	85±2	30±3	4	Room temperature	5±3	$ \Delta V_{1mA}/V_{1mA} \leq 5\%$ No visible damage
Step	Temperature (°C)	Period (minutes)																
1	-40±3	30±3																
2	Room temperature	5±3																
3	85±2	30±3																
4	Room temperature	5±3																
High Temp. Load	IEC61051-1	85±2°C, 1000±24 hrs at V _{DC} or V _{rms} (Max. Continuous Voltage)	$ \Delta V_{1mA}/V_{1mA} \leq 10\%$ No visible damage															
8/20μs Surge Life	IEC61051-1 (IEC60060-2)	8/20μs waveform, 10 surge currents, unipolar, interval 30 secs, amplitude corresponding to max. surge current derating curves for 8/20μs.	$ \Delta V_{1mA}/V_{1mA} \leq 10\%$ No visible damage															
10/1000μs Surge Life	IEC61051-1 (IEC60060-2)	10/1000μs waveform, 10 surge currents, unipolar, interval 2 mins, amplitude corresponding to max. surge current derating curves for 10/1000μs.	$ \Delta V_{1mA}/V_{1mA} \leq 10\%$ No visible damage															
Limited Current Abnormal Overvoltage Test	UL1449- 5 th	Test voltage: refer to UL 1449 5 th Table 45.4 Short current condition: <table border="1"> <thead> <tr> <th>Series</th> <th>Short Current (A)</th> </tr> </thead> <tbody> <tr> <td>TVT14</td> <td>0.125A, 0.5A, 2.5A, 5A</td> </tr> <tr> <td>TVT20, 25</td> <td>0.5A, 2.5A, 5A, 10A</td> </tr> </tbody> </table> <p>Each of four previously untested TVT samples to be connected to an ac power supply having an open circuit voltage equal to U_{oc}. The power supply is to incorporate a series variable resistor that can be adjusted to obtain the short-circuit values (I_{sc}) respectively. The four samples are to be energized for 7 hrs, or until current to, or body temperature attain equilibrium, or until the sample becomes disconnected from the ac supply.</p>	Series	Short Current (A)	TVT14	0.125A, 0.5A, 2.5A, 5A	TVT20, 25	0.5A, 2.5A, 5A, 10A	No flame									
Series	Short Current (A)																	
TVT14	0.125A, 0.5A, 2.5A, 5A																	
TVT20, 25	0.5A, 2.5A, 5A, 10A																	
Voltage Proof	IEC61051	Metal balls method, 2500 V _{ac} 1 min	No visible damage															
Varistor Voltage Temp. Coefficient	Specification Standard	$\frac{V_{1mA@85^\circ C} - V_{1mA@25^\circ C}}{V_{1mA@25^\circ C}} \times \frac{1}{60} \times 100\% (\%/^\circ C)$ $\frac{V_{1mA@-40^\circ C} - V_{1mA@25^\circ C}}{V_{1mA@25^\circ C}} \times \frac{1}{65} \times 100\% (\%/^\circ C)$	-0.05 ≤ T _c ≤ 0.05 (%/°C)															

Metal Oxide Varistor : TVT Series

Thermally Protected Varistor Series



■ Packaging

● Bulk Packing

Series	Quantity (pcs/bag)
TVT14	50
TVT20	20
TVT25	20

● Reel Packing

Series	Varistor Voltage	Pcs/Reel
TVT14	820~122	300
TVT20	820~781	200
TVT20	821~122	150

● Box Packing (for Potting Structure)

Series	Varistor Voltage	Quantity (pcs/box)	Figure
TVT14	820-561	50	1
TVT25	820-511, 561-122	40	2
TVT25	142	30	3

(Unit: mm)

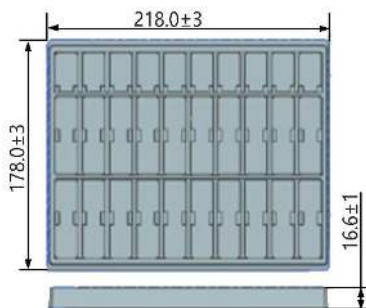

Figure 1

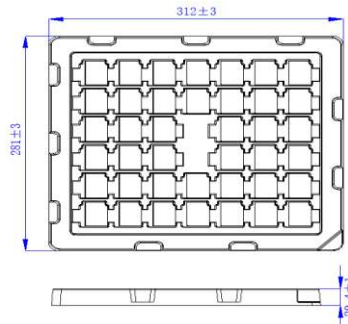

Figure 2

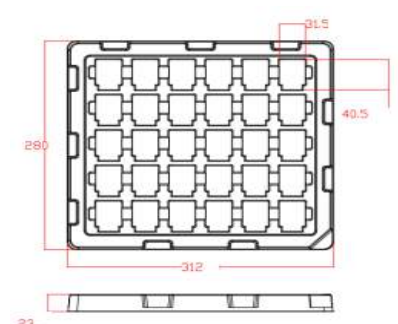

Figure 3

■ Warehouse Storage Conditions of Products

- Storage Conditions:
 1. Storage temperature: $-10^{\circ}\text{C}\sim+40^{\circ}\text{C}$
 2. Relative humidity: $\leq 75\%RH$
 3. Keep away from corrosive atmosphere and sunlight.
- Period of Storage: 1 year