

GN 722.2

Steel / Stainless Steel

Square Cam Action Spring Latches

Lock-Out, with Mounting Flange, Right-Angled to the Latch Pin



JW WINCO
A Ganter Company

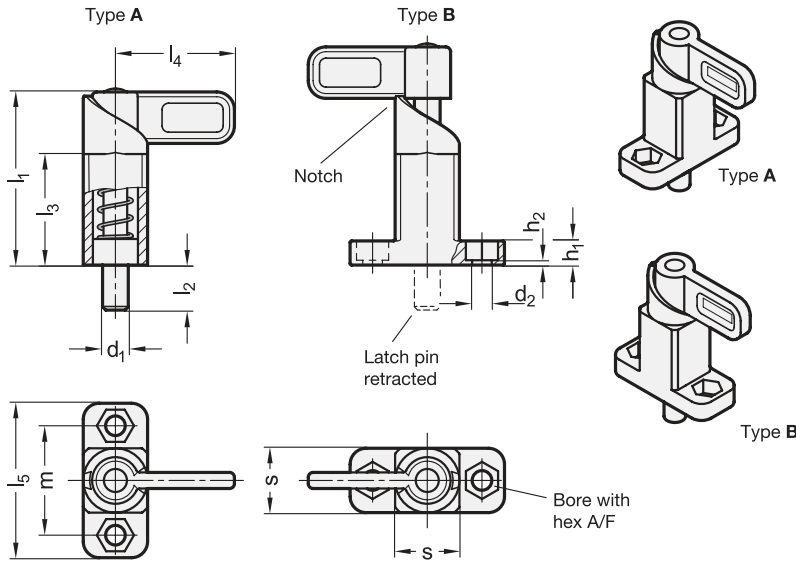

SS Stainless Steel

3 Type

- A** Latch position right-angled to mounting holes
- B** Latch position parallel to mounting holes

Metric table

Dimensions in: millimeters - inches

d ₁ Pin -0.05 +0.1 Bore +0.3	s	d ₂ +0.2	h ₁	h ₂	l ₁ ≈	l ₂	l ₃	l ₄	l ₅	m	A/F	Spring load ≈	
												Initial	End
8 0.31	20 0.79	6.1 0.24	7.5 0.30	1.5 0.06	54 2.13	14 0.55	35 1.38	37 1.46	48 1.89	34 1.34	10	15 N 3.37 lbf	50 N 11.24 lbf
10 0.39	20 0.79	6.1 0.24	7.5 0.30	1.5 0.06	54 2.13	14 0.55	35 1.38	37 1.46	48 1.89	34 1.34	10	15 N 3.37 lbf	50 N 11.24 lbf
12 0.47	20 0.79	6.1 0.24	7.5 0.30	1.5 0.06	54 2.13	14 0.55	35 1.38	37 1.46	48 1.89	34 1.34	10	15 N 3.37 lbf	50 N 11.24 lbf
14 0.55	20 0.79	6.1 0.24	7.5 0.30	1.5 0.06	54 2.13	14 0.55	35 1.38	37 1.46	48 1.89	34 1.34	10	15 N 3.37 lbf	50 N 11.24 lbf
16 0.63	30 1.18	10.1 0.40	15 0.59	5 0.20	83 3.27	20 0.79	54 2.13	55 2.17	80 3.15	55 2.17	17	30 N 6.74 lbf	110 N 24.73 lbf
20 0.79	30 1.18	10.1 0.40	15 0.59	5 0.20	83 3.27	20 0.79	54 2.13	55 2.17	80 3.15	55 2.17	17	30 N 6.74 lbf	110 N 24.73 lbf

Specification

- Body
Steel precision casting
- Zinc plated, blue passivated finish **ZB**
- Zinc plated and powder coated Black, RAL 9005, textured finish **SW**
- Lever arm
Steel precision casting
Zinc plated, blue passivated finish
- Latch pin
Steel
Zinc plated, blue passivated finish
- Spring
Stainless steel AISI 316Ti
- Body / lever arm
Stainless steel precision casting AISI 316 **A4**
- Latch pin
Stainless steel AISI 316
- Spring
Stainless steel AISI 316Ti
- Load Rating Information → page 2103
- Stainless Steel Characteristics → page 2143
- RoHS compliant

Information

With GN 722.2 square cam action spring latches, the latch pin is withdrawn over the cam of the body by rotating the lever arm 180°. If the latch pin may need to be retracted periodically, the notch allows for safe positioning while the latch pin is held in the retracted position. The ZB and SW versions are designed for applications in steel construction, whereas the A4 stainless steel version is suitable for use in particularly aggressive environments.

The dimensional tolerances between latch pin and body are selected so that the functional reliability is guaranteed even with rough applications or in case of contamination.

There are several options for fastening. The hexagonal mounting holes allow the use of DIN 912 socket cap screws and hex screws or nuts according to DIN 931 or DIN 934.

see also...

- List of Cam Action Indexing Plunger Types → page 1001
- Locating Bushings GN 412.2 / GN 412.4 → page 996
- Cam Action Indexing Plungers GN 612.10 (with Mounting Flange) → www.jwwinco.com

How to order	
1	Pin diameter d ₁
2	Square s
3	Type
4	Finish (Material)

GN 722.2-12-20-B-SW

3.1
3.2
3.3
3.4
3.5
3.6
3.7
3.8
3.9
3.10