

SCM5B39

Current Output Modules



Description

Each SCM5B39 current output module provides a single channel of analog output. The track-and-hold circuit in the input stage can be operated in a hold mode where one DAC can supply many output modules, or a track mode where one DAC is dedicated to each module. In addition to the track-and-hold circuit, each module provides signal buffering, isolation, filtering, and conversion to a high-level current output (Figure 1).

Setting of the track or hold mode is controlled by the logic state of WR EN\, module pin 23. When pin 23 is low, the track mode is enabled. If pin 23 is high, the hold mode is enabled. The module is designed with a completely isolated computer side circuit which can be floated to $\pm 50V$ from Power Common, pin 16. This complete isolation means that no connection is required between I/O Common and Power Common for proper operation of the track and hold circuit. For a low state, simply connect pin 23, the Write-Enable pin, to I/O Common, pin 19.

The SCMPB02 and SCMPB06 backpanels allow host computer control of the WR EN\ control line, which allows multiplexing of one host DAC to up to 64 SCM5B39 output modules. During power-up, the output remains at 0mA for 100ms on all models except the SCM5B39-07, which allows the track-and-hold circuit to be initialized.

A special circuit in the output stage of the module provides protection against accidental connection of power-line voltages up to 240VAC on all models.

Features

- Accepts High-Level Voltage or Process Current Input
- Unipolar or Bipolar Current Output
- 1500Vrms Transformer Isolation
- ANSI/IEEE C37.90.1 Transient Protection
- Output Protected to 240VAC Continuous
- 110dB CMR
- 400Hz Signal Bandwidth
- $\pm 0.03\%$ Accuracy
- $\pm 0.005\%$ Linearity
- CSA C/US Certified
- CE and ATEX Compliant
- Mix and Match SCM5B Types on Backpanel

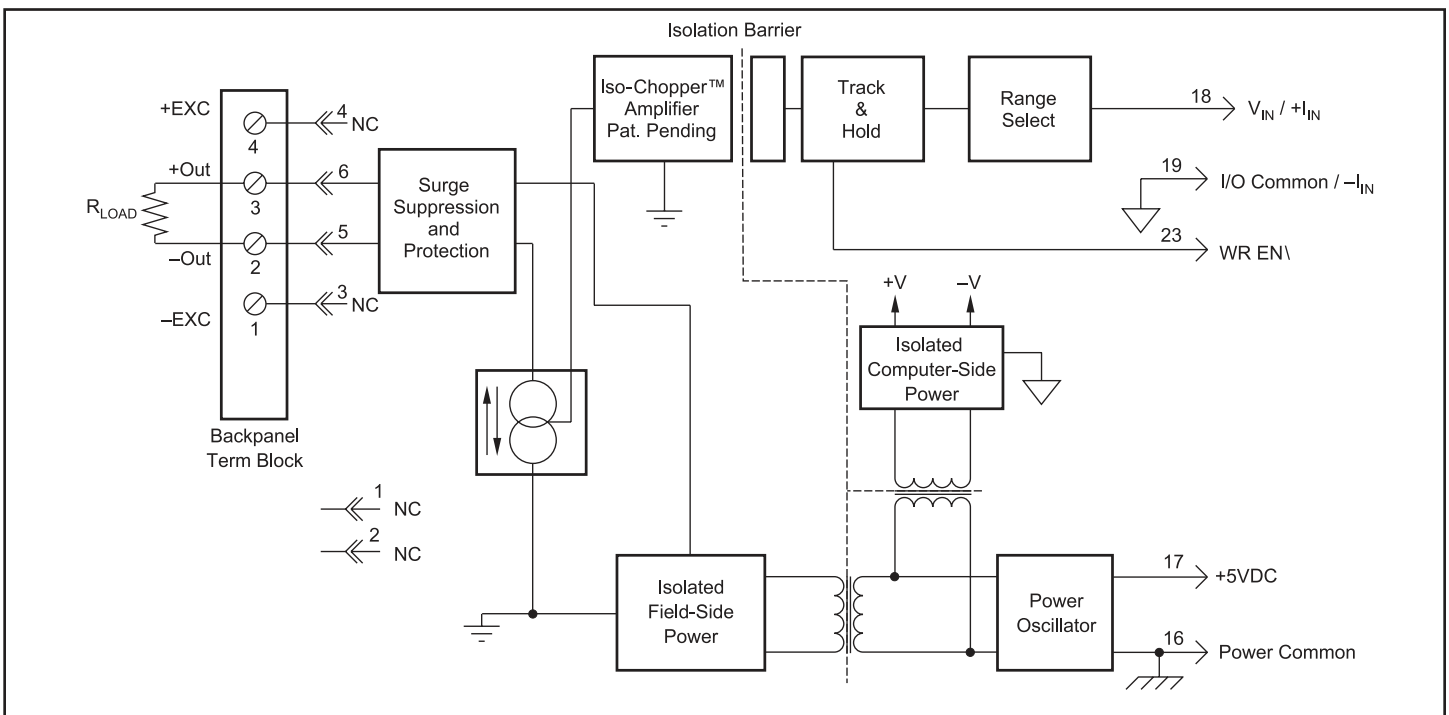

Figure 1: SCM5B39 Block Diagram

Specifications Typical* at $T_A = +25^\circ\text{C}$ and +5VDC power

Module	Unipolar Output Current SCM5B39-01,-02,-03,-04,-05	Bipolar Output Current SCM5B39-07
Input Voltage Range	$\pm 5\text{V}$ or 0V to $+5\text{V}$	$\pm 10\text{V}$
Input Current Range (-05)	0 to 20mA	N/A
Input Voltage Maximum	$\pm 36\text{V}$ (no damage)	*
Input Current, Maximum (-05)	75mA (no damage)	N/A
Input Resistance	50M Ω	2M Ω
Input Resistance (-05)	250 Ω	N/A
Output Current Range	0 to 20mA or 4 to 20mA	$\pm 20\text{mA}$
Power-Up Delay ⁽¹⁾	100ms	N/A
Current Out	0mA	N/A
Over Range Capability	10%	*
Output Compliance Voltage (Open Circuit)	22VDC	$\pm 15\text{VDC}$
Load Resistance Range	0 to 650 Ω (0 to 750 Ω for Power Supply Voltage greater than 4.95VDC)	0 to 450 Ω (0 to 500 Ω for Power Supply Voltage greater than 4.95VDC)
Output I Under Fault, max Output Protection	26mA	*
Continuous	240Vrms max	*
Transient	ANSI/IEEE C37.90.1	*
CMV, Output to Input		
Continuous	1500Vrms max	*
Transient	ANSI/IEEE C37.90.1	*
CMR (50Hz or 60Hz)	110dB	*
NMR (-3dB)	80dB per Decade above 400Hz	80dB per Decade above 275Hz
Accuracy	$\pm 0.03\%$ Span	$\pm 0.05\%$ Span
Linearity	$\pm 0.005\%$ Span	$\pm 0.03\%$ Span
Stability		
Offset	$\pm 0.5\mu\text{A}/^\circ\text{C}$	*
Gain	$\pm 20\text{ppm}/^\circ\text{C}$	$\pm 40\text{ppm}/^\circ\text{C}$
Noise		
Output Ripple, 100kHz	10 μA -p-p	*
Bandwidth, -3dB	400Hz	275Hz
Rise Time, 10 to 90% Span	1.0ms	1.2ms
Sample and Hold		
Output Droop Rate	40 $\mu\text{A}/\text{s}$	*
Acquisition Time	50 μs	*
Track-and-Hold Enable Control		
Max Logic "0"	+0.8V	*
Min Logic "1"	+2.4V	*
Max Logic "1"	+36V	*
Input Current "0"	0.5 μA	*
Power Supply Voltage	+5VDC $\pm 5\%$	*
Power Supply Current	170mA	130mA
Power Supply Sensitivity	$\pm 0.5\mu\text{A}/\%$ typ	*
Mechanical Dimensions (h)(w)(d)	2.28" x 2.26" x 0.6" (58mm x 57mm x 15mm)	*
Environmental		
Operating Temp. Range	-40°C to $+85^\circ\text{C}$	*
Storage Temp. Range	-40°C to $+85^\circ\text{C}$	*
Relative Humidity	0 to 95% Noncondensing	*
Emissions EN61000-6-4	ISM, Group 1	*
Radiated, Conducted	Class A	*
Immunity EN61000-6-2	ISM, Group 1	*
RF	Performance A $\pm 0.5\%$ Span Error	*
ESD, EFT	Performance B	*

NOTES:

*Contact factory or your local Dataforth sales office for maximum values.

* Same as -01, -02, -03, -04, -05 modules.

(1) See Product Description for further details.

Ordering Information

Model	Input Range	Output Range	Bandwidth
SCM5B39-01	0V to +5V	4mA to 20mA	400Hz
SCM5B39-02	-5V to +5V	4mA to 20mA	400Hz
SCM5B39-03	0V to +5V	0mA to 20mA	400Hz
SCM5B39-04	-5V to +5V	0mA to 20mA	400Hz
SCM5B39-05	0mA to 20mA	0mA to 20mA	400Hz
SCM5B39-07	-10V to +10V	-20mA to +20mA	275Hz

Refer to SCM5B392 specifications, p.27, for additional current output models.