

LOC		DIST		REVISIONS			
P	LTR	DESCRIPTION	DATE	DN	APVD		
E1		REVISED PER ECR-15-006687	21OCT2015	NK	NL		

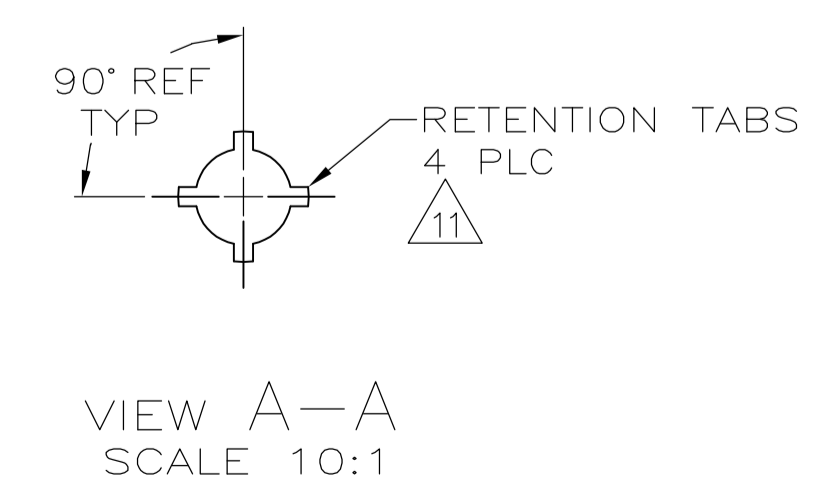
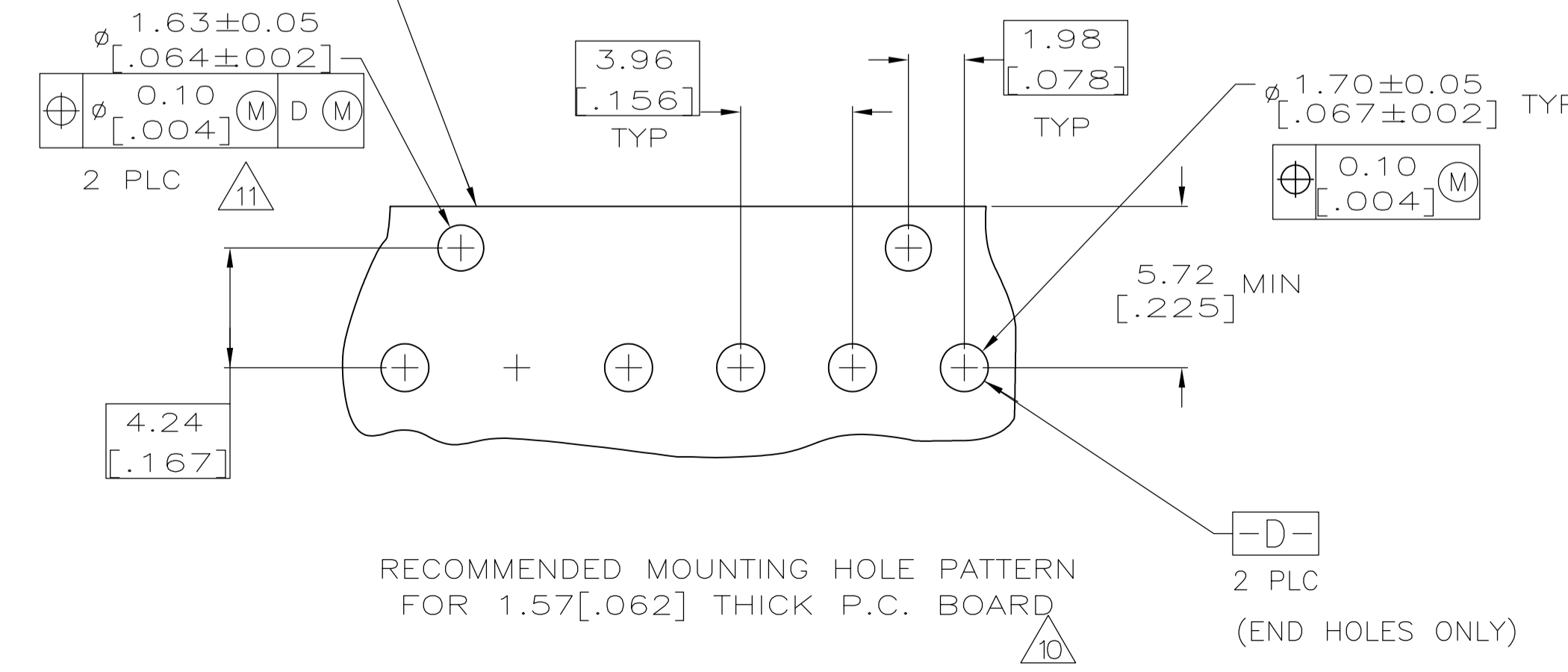
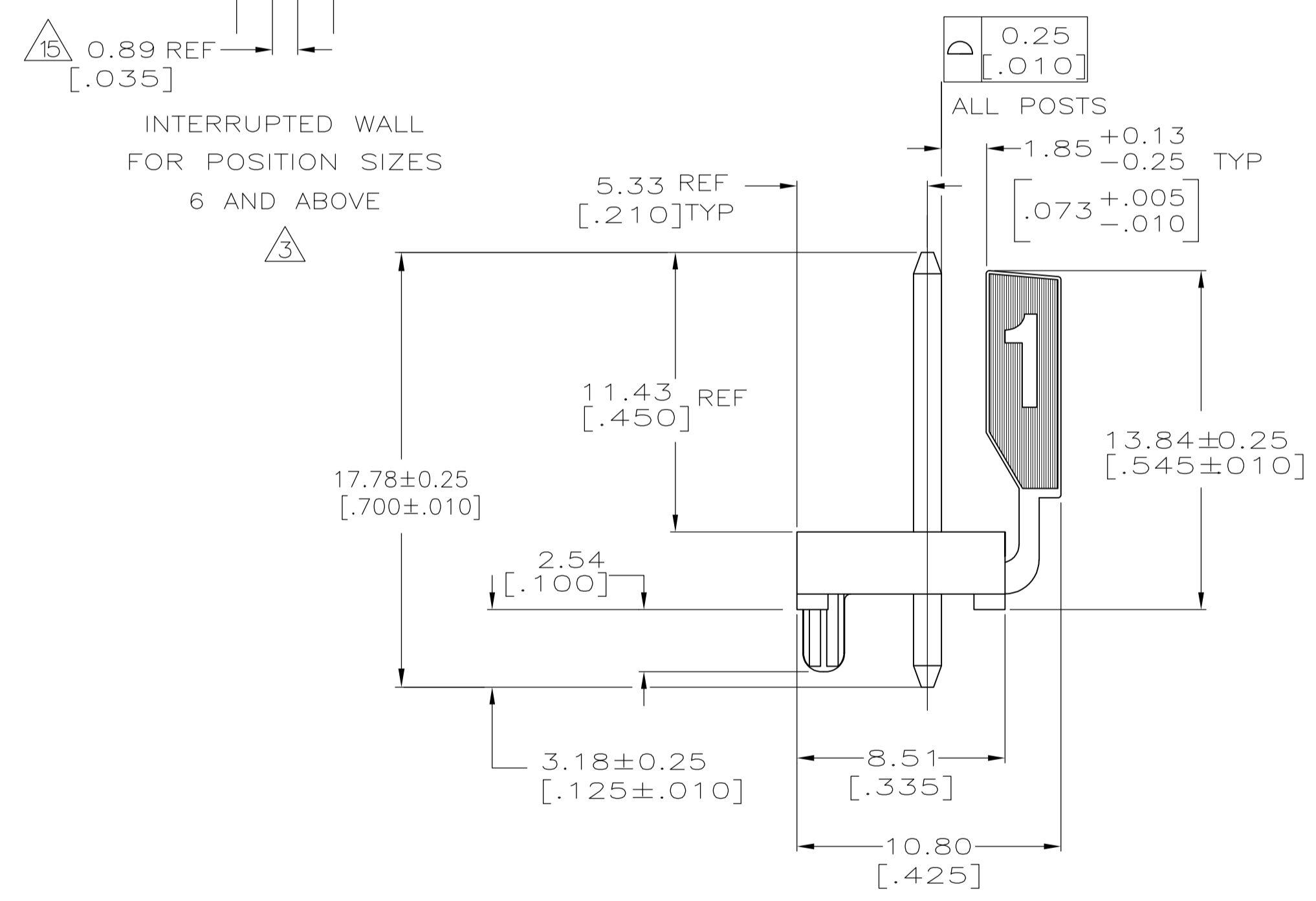
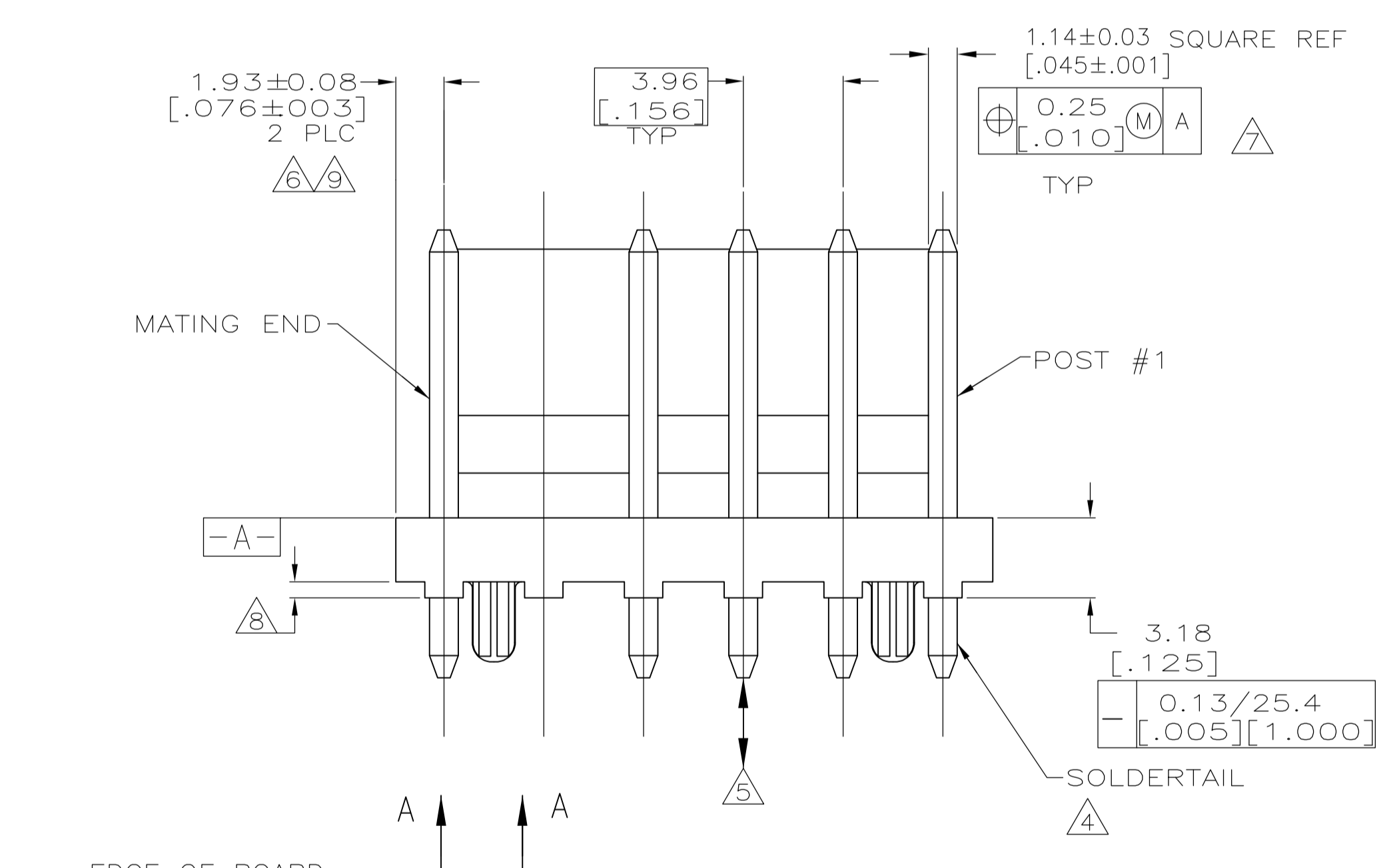
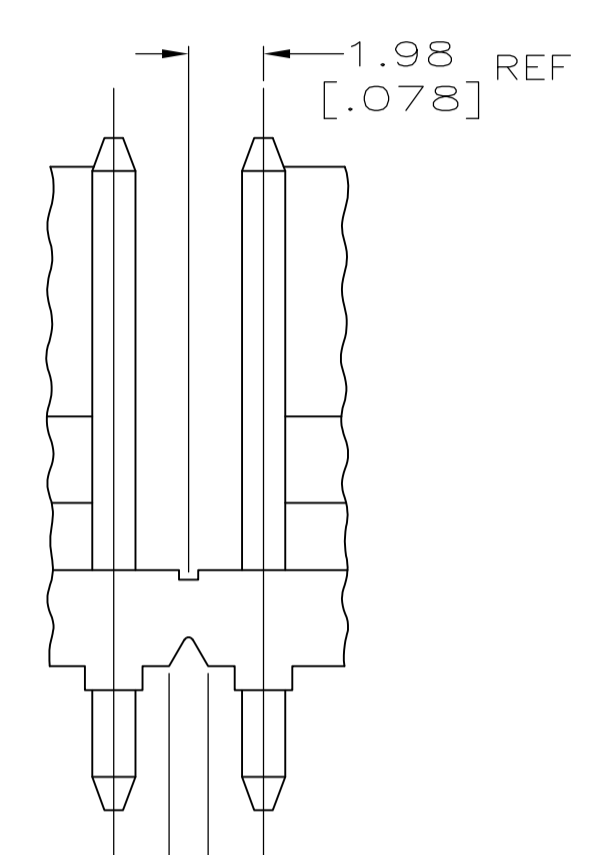
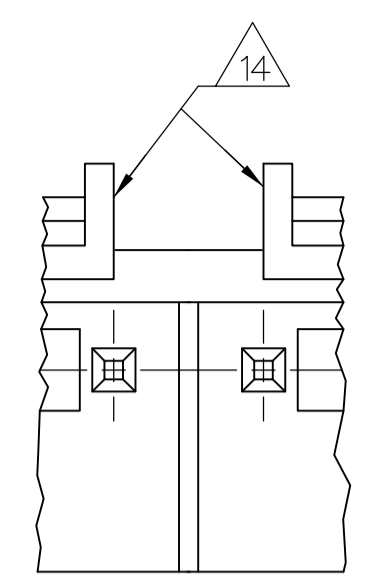
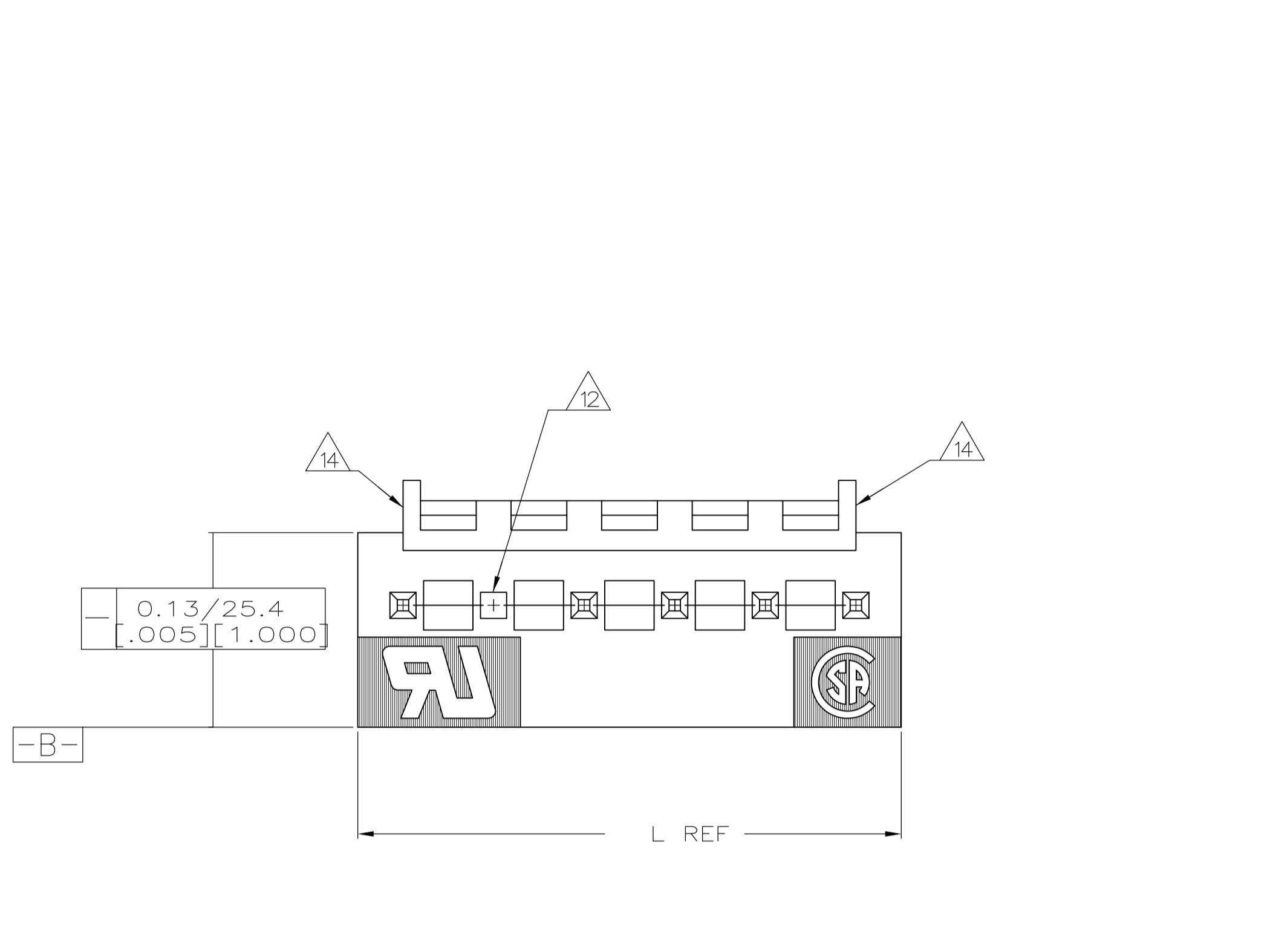

- 1 MATERIAL
HOUSING: THERMOPLASTIC POLYESTER, GLASS FILLED, UL94V-0.
POST: COPPER ALLOY
- 2 FINISH
HOUSING: NATURAL
POST, BRIGHT TIN-LEAD (93/7) PLATE, 0.00380[.000150]-0.00880[.000350] OVER NICKEL UNDERPLATE, 0.0013[.00005] MIN THICK FOR -5 & 6.
POST, MATTE TIN PLATE, 0.00380[.000150]-0.00880[.000350] OVER NICKEL UNDERPLATE, 0.0013[.00005] MIN THICK FOR -35 & -36.
- 3 ALL POSITION SIZES HAVE THE BACKWALL NOTCHED ON BOTH ENDS AS SHOWN.
POSITION SIZES 6 AND ABOVE HAVE AN INTERRUPTED BACKWALL AT VARIOUS LOCATIONS. (SEE TABLE FOR INTERRUPTION(S) LOCATIONS).
- 4 POST SOLDER TAILS COMPLY WITH AMP SOLDERABILITY SPEC 109-11-2.
- 5 POST WITHSTANDS 13.34N (3 LB) MIN AXIAL FORCE IN EITHER DIRECTION WITHOUT DISLODGING.
- 6 APPLIES AT -A-.
- 7 APPLIES WHEN THE HEADER IS STRAIGHT.
- 8 PLASTIC PROJECTIONS PERMITTED IN THIS ZONE.
- 9 COORDINATE DIMENSIONS APPLIES FROM THE CENTER OF THE ACTUAL FEATURE.
- 10 SOLDER SIDE OF BOARD IS SHOWN.
- 11 THE RETENTION TABS PROVIDE A ONE-TIME INTERFERENCE FIT IN THE 1.63[.064] DIAMETER BOARD HOLE FOR HEADER ASSEMBLY RETENTION DURING SOLDERING. FOUR TABS PER PEG, TWO PEGS PER HEADER ASSEMBLY.
- 12 POST NO. 5 OMITTED.
- 13 DIMENSIONS IN BRACKETS ARE IN INCHES
- 14 EDGE OF POLARIZING LOCK WALL TO BE IN LINE WITH CENTERLINE OF ADJACENT POST WITHIN ±0.13 [.005].
- 15 NOTCH SHOWN MAY OR MAY NOT APPEAR.
- 16 OBSOLETE PART NUMBER

CALLOUT	POSITIONS	BACKWALL INTERRUPTION(S) BETWEEN POST	L	NO OF POSITIONS	PART NO
16	3 & 4		23.65 [.931]	6	3-647068-6
	-		19.69 [.775]	5	3-647068-5
16	3 & 4		23.65 [.931]	6	647068-6
16	-		19.69 [.775]	5	647068-5

NOTES: BACKWALL INTERRUPTION(S) BETWEEN POST, L, NO OF POSITIONS, PART NO.

THIS DRAWING IS A CONTROLLED DOCUMENT.

DIMENSIONS: mm [INCHES]	TOLERANCES UNLESS OTHERWISE SPECIFIED:	DIN K. WHITAKER 02AUG2005	CK: D. ROSSI 02AUG2005	NAME: MTA-156 HEADER ASSEMBLY, POLARIZED LOCK, STRAIGHT .045 SQUARE POST, TIN OR TIN-LEAD PLATED W/RETENTION LEGS, POST NO. 5 OMITTED
0 PLC ± -	1 PLC ± -	APVD: D. ROSSI 02AUG2005	PRODUCT SPEC	APPLICATION SPEC
2 PLC ± ± 0.13[.005]	3 PLC ± -	SIZE: A1	WEIGHT: -	RESTRICTED TO: -
4 PLC ± -	ANGLES ± -	SCALE: 5:1	DRAWING NO: 00779	CUSTOMER DRAWING

STE TE Connectivity

SCALE: 5:1 SHEET 1 OF 1 REV E1