

uVGA-III



Datasheet

Revision 1.8

Copyright © 2023 4D Systems

Content may change at any time. Please refer to the resource centre for latest documentation.

Contents

1. Overview	3
2. Description	4
3. Features	5
4. Pin Configuration and Summary	6
5. Hardware Interface - Pins	9
5.1. Serial Ports - TTL Level	9
5.2. General Purpose I/O	10
5.3. System Pins	11
5.4. VGA Output Header and Pads	12
6. Firmware / PmmC Programming	13
7. Module Features	14
7.1. VGA - Interface	14
7.2. PICASO Processor	14
7.3. Audio	14
7.4. SD/SDHC Memory Cards	15
7.5. FAT16	15
8. Hardware Tools	16
8.1. Programming Cable/Adaptor	16
9. Programming Language	17
10. Workshop4 IDE	18
11. Mechanical Details	19
12. Schematic Diagram	20
12.1. Sheet 1	20
12.2. Sheet 2	21
13. Specifications	22
14. Revision History	23

1. Overview

The **uVGA-III** is a compact and cost-effective VGA Graphics Engine packed with plenty of features, ready to become the GUI for your target application and capable of being an interface controller for many applications.

Embedded at the heart of the design is the **PICASO** processor, which is driven by a highly optimised virtual core engine called **EVE** (Extensible Virtual Engine). An extensive range of hardware and software peripherals have been integrated into the design, to give the user freedom to adapt the module to suit almost any application.

The module combines a display driver capable of 320x240 (QVGA), 640x480 (VGA) and 800x480 (WVGA) resolution output to a standard VGA display, micro-SD card connector, along with a group of general purpose input/output pins (GPIO's), including I2C and serial UART communications.

This module serves as a perfect solution to connect to an external VGA monitor for an application requiring animation, slideshows, images or sound. This **PICASO**-driven Intelligent Display Module is a perfect example of where art meets technology.

Audio support provided on the display module is supplied by the **PICASO** processor, outputting a line-level audio signal, ready to drive an external amplifier of choice. A simple instruction enables the user to play audio files while continuing the execution of the user application code, such as display updates, communications and much more.

The **micro-SD** card slot provides the user with expandable memory space suitable for multimedia file retrieval, including images, animations and movie clips, as well as data logging applications.

The module can be programmed as a master or slave device using the Workshop4 IDE Software, but can also be configured as a serial slave for use with your favourite Host Controller. Freedom is at your fingertips with the intelligent **uVGA-III** VGA Graphics Engine module.

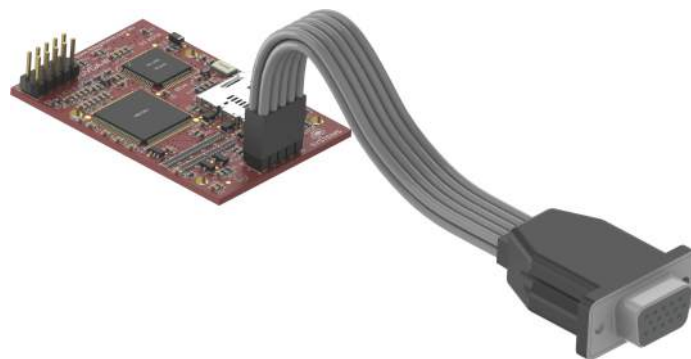
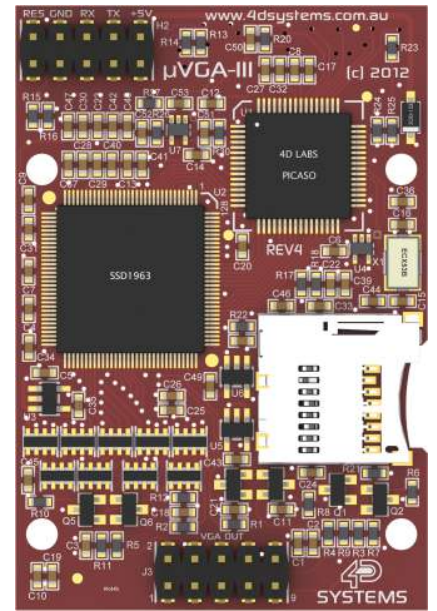

2. Description

The uVGA-III module is a compact and cost-effective standalone VGA graphics engine powered by the PICASO graphics processor. It can provide a QVGA/VGA/WVGA graphics solution to any embedded project with its powerful graphics, text, image and animation capabilities, along with countless more features built inside the module.

Depending on the programming environment selected when using 4D Systems' Workshop4 IDE Software, the user can choose to program the uVGA-III module as a stand-alone device, or as a slave device to an external host controller.

When the uVGA-III is used as a stand-alone device, it allows the user to take complete control of all available resources on that hardware platform such as the Serial Ports, uSD memory card, I/O pins, etc. This eliminates the need for an external host controller/processor to drive the uVGA-III module via serial commands. It provides the user complete control over the hardware module allowing them to quickly develop practical applications.

When the uVGA-III is used as a serial slave device to an external host controller, the host sends specific commands over its serial UART to the uVGA-III to produce the desired user displays.

The uVGA-III features a remote VGA connector, which can be disconnected from the PCB. The remote VGA connector enables flexible mounting and connection options when using the uVGA-III.

A 30-way header is provided on the rear of the PCB, which is left unpopulated from the factory, however, the header is provided with the module. This can be soldered by the user if required, to gain additional IO and comms if required. Wires can also be soldered directly to the PCB if desired.

3. Features

- Simple VGA interface to a variety of monitors and LCD screens.
- Supports the following resolutions:
 - 320 x 240 (QVGA)
 - 640 x 480 (VGA)
 - 800 x 480 (WVGA)
- Supports RGB 65K true-to-life colours.
- Easy 5-pin interface to any host device: VCC, TX, RX, GND, RESET
- Powered by the 4D-Labs PICASO processor (also available as a separate OEM IC)
- 14KB of flash memory for user code storage and 14KB of SRAM for user variables, or 14KB shared user code and program variables.
- 2 x Asynchronous hardware serial UART ports (COM0, COM1), TTL interface, with 300 to 600K baud.
- 1 x I2C interface (Master).
- 8 x 16-bit timers with 1-millisecond resolution.
- 13 x General Purpose I/O pins. Supports fast 8-bit parallel data transfer through Upper 8 bits.
- On-board micro-SD memory card adaptor for multimedia storage and data logging purposes. HC memory card support is also available for cards larger than 4GB.
- DOS-compatible file access (FAT16 format) as well as low-level access to card memory.
- A dedicated Line-Level PWM Audio pin driven by WAV files from a micro-SD card.
- Built-in extensive 4DGL graphics and system library functions.
- Display full colour images, animations, icons and video clips.
- Supports all available Windows fonts.
- A 30-pin header for I/O expansion (supplied but not soldered onto the PCB)
- 15-pin D-type standard VGA connector to interface to any external VGA monitor, on a remote and detachable cable.
- 4.0V to 5.5V range operation (single supply).
- Module dimensions: 39.0 x 63.0 x 21.5mm
- Weight ~ 17g.
- RoHS Compliant.

4. Pin Configuration and Summary

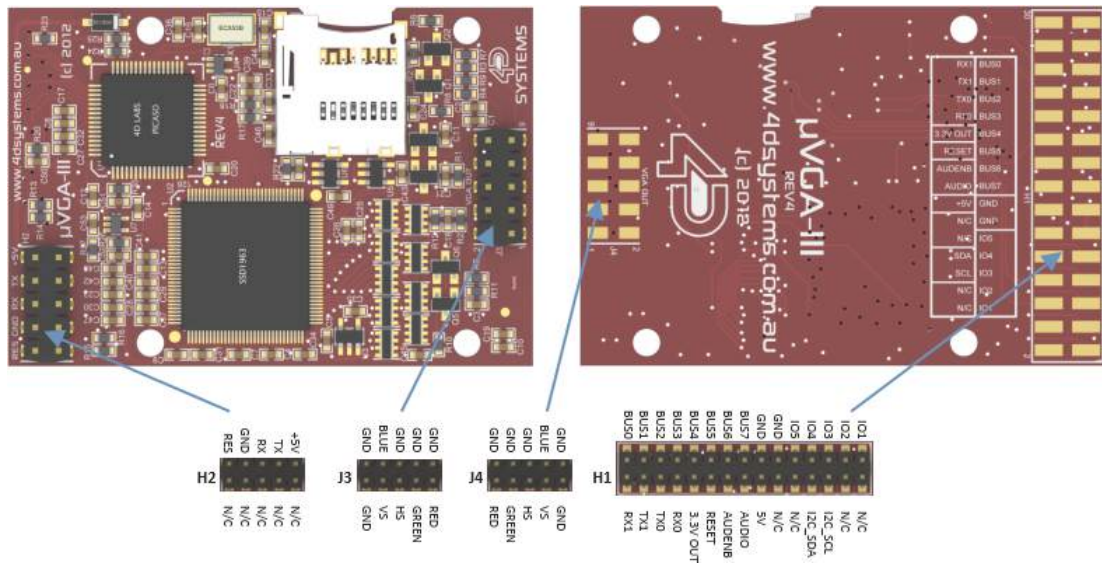

 H2 Pinouts (Programming Header)			
Pin	Symbol	I/O	Description
1	N/C	-	Not connected
2	RES	I	Master Reset signal. Internally pulled up to 3.3V via a 10K resistor. An active Low pulse greater than 2 micro-seconds will reset the module. If the module needs to be reset externally, only use open collector-type circuits. This pin is not driven low by any internal conditions. The host should control this pin via one of its port pins using an open collector/drain arrangement.
3	N/C	-	Not connected
4	GND	P	Supply Ground
5	N/C	-	Not connected
6	RX	I	Asynchronous Serial UART Receive pin, TTL level. Connect this pin to the Transmit (Tx) signal of other serial devices. Used in conjunction with the TX pin for programming this module. This pin is tolerant up to 5.0V levels.
7	N/C	-	Not connected
8	TX	O	Asynchronous Serial UART Transmit pin, TTL level. Connect this pin to the Receive (Rx) signal of other serial devices. Used in conjunction with the RX pin for programming this module. This pin is tolerant up to 5.0V levels.
9	N/C	-	Not connected
10	VIN	P	Main Voltage Supply +ve input pin. Reverse polarity protected. The range is 4.0V to 5.5V, nominal 5.0V.

 **Note**

I = Input, **O** = Output, **P** = Power

H1 Pinouts (I/O Expansion Header)

Pin	Symbol	I/O	Description
1	IO1	I/O	General Purpose Input Output 1 Pin
2	N/C	-	Not connected
3	IO2	I/O	General Purpose Input Output 2 Pin
4	N/C	-	Not Connected
5	IO3	I/O	General Purpose Input Output 3 Pin
6	SCL	O	I2C Clock Output
7	IO4	I/O	General Purpose Input Output 4 Pin
8	SDA	I/O	I2C Bidirectional Data
9	IO5	I/O	General Purpose Input Output 5 Pin
10	N/C	-	Not connected
11	GND	P	Supply Ground
12	N/C	-	Not connected
13	GND	P	Supply Ground
14	+5V	P	Supply Input +ve, 4.0V to 5.5V, 5.0V Nominal
15	BUS7	I/O	IO Bus (BUS0..7) bit 7
16	AUDIO	O	Audio Output, TTL Line level for connecting to an external amplifier
17	BUS6	I/O	IO Bus (BUS0..7) bit 6
18	AUDENB	O	Audio Enable Output, to enable an external Amplifier (if required)
19	BUS5	I/O	IO Bus (BUS0..7) bit 5
20	RES	I	Master Reset, Active Low (GND) (Refer H2 Pinout)
21	BUS4	I/O	IO Bus (BUS0..7) bit 4
22	3.3V OUT	P	3.3V Output, 20mA Max supply
23	BUS3	I/O	IO Bus (BUS0..7) bit 3
24	RX0	I	Asynchronous serial port 0 receive pin. COM0 (same as the RX pin on the H2 Programming Header)
25	BUS2	I/O	IO Bus (BUS0..7) bit 2
26	TX0	O	Asynchronous serial port 0 transmit pin. COM0 (same as the TX pin on the H2 Programming Header)
27	BUS1	I/O	IO Bus (BUS0..7) bit 1

Pin	Symbol	I/O	Description
28	TX1	O	Asynchronous serial port 1 transmit pin. COM1
29	BUS0	I/O	IO Bus (BUS0..7) bit 0
30	RX1	I	Asynchronous serial port 1 receive pin. COM1

 **Note**

I = Input, **O** = Output, **P** = Power

 **J3 and J4 Pin Outs (VGA Headers)**

Pin	Symbol	I/O	Description
1	GND	P	Ground
2	GND	P	Ground
3	VS	O	Vertical Sync
4	BLUE	O	Blue (RGB)
5	HS	O	Vertical Sync
6	GND	P	Ground
7	GREEN	O	Green (RGB)
8	GND	P	Ground
9	RED	O	Red (RGB)
10	GND	P	Ground (STRIPED WIRE ON THE VGA CABLE, FOR J3 ONLY – See the VGA Output Header and Pads section)

 **Note**

I = Input, **O** = Output, **P** = Power

5. Hardware Interface - Pins

The uVGA-III provides both a hardware and software interface. This section describes in detail the hardware interface pins of the device.

5.1. Serial Ports - TTL Level

The uVGA-III has two dedicated hardware Asynchronous Serial UART ports that can communicate with external serial devices. These are referred to as the COM0 and the COM1 serial ports.

The primary features are:

- Full-Duplex 8-bit data transmission and reception.
- Data format: 8 bits, No Parity, 1 Stop bit.
- Independent Baud rates from 300 baud up to 600K baud.
- Single byte transmits and receives a fully buffered service. The buffered service feature runs in the background capturing and buffering serial data without the user application having to constantly poll any of the serial ports. This frees up the application to service other tasks.

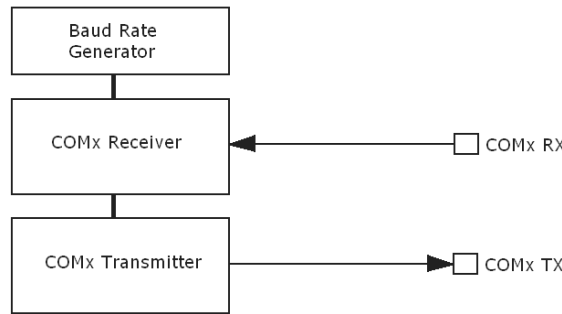

A single-byte serial transmission consists of the start bit, 8 bits of data followed by the stop bit. The start bit is always 0, while a stop bit is always 1. The LSB (Least Significant Bit, Bit 0) is sent out first following the start bit. The figure below shows a single-byte transmission timing diagram.

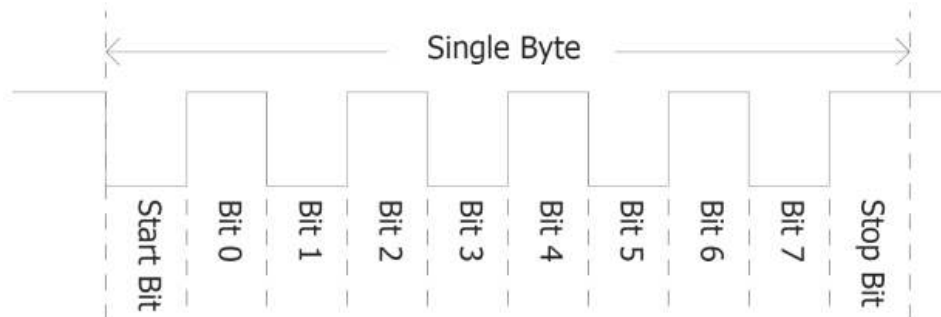

COM0 is also the primary interface for 4DGL user program downloads and chip configuration (PmmC programming). Once the compiled 4DGL application program (EVE byte-code) is downloaded and the user code starts executing, the serial port is then available to the user application. Refer to the [Firmware / PmmC Programming](#) for more details on this subject.

TX0 pin (Serial Transmit COM0):

Asynchronous Serial port COM0 transmit pin, TX0. Connect this pin to the external serial device receive (Rx) signal. This pin is 5.0V tolerant.

RX0 pin (Serial Receive COM0):

Asynchronous Serial port COM0 receive pin, RX0. Connect this pin to an external serial device transmit (Tx) signal. This pin is 5.0V tolerant.

TX1 pin (Serial Transmit COM1):

Asynchronous Serial port COM1 transmit pin, TX1. Connect this pin to the external serial device receive (Rx) signal. This pin is 5.0V tolerant.

RX1 pin (Serial Receive COM1):

Asynchronous Serial port COM1 receive pin, RX1. Connect this pin to an external serial device transmit (Tx) signal. This pin is 5.0V tolerant.

5.2. General Purpose I/O

There are 13 general purpose Input/Output (GPIO) pins available to the user. These are grouped as IO1..IO5 (Note for IO1, IO2 and IO3 below) and BUS0..BUS7. Power-Up Reset default is all INPUTS.

The 5 I/O pins (IO1..IO5), provide flexibility for individual bit operations while the 8 pins (BUS0..BUS7), known as GPIO BUS, serve collectively for byte-wise operations. The IO4 and IO5 also act as strobing signals to control the GPIO Bus. GPIO Bus can be read or written by strobing a low pulse (50ns duration or greater) the IO4/BUS_RD or IO5/BUS_WR for read or write respectively.

Please refer to the [Picaso Internal Functions Manual](#) for detailed information.

IO1-IO5 pins (excluding IO3) (2 x GPIO pins):

General purpose I/O pins. Each pin can be individually set for INPUT or an OUTPUT.

IO3 pins (Peripheral Supply pin):

IO3 is controllable via the processor, or via the H2 Interface pin driven by an external circuit. If IO3 is set as OUTPUT and driven HIGH the uSD and VGA output are enabled, and disabled when driven LO. Set as INPUT to use an external circuit to drive this pin.

IO4/BUS_RD pin (GPIO IO4 or BUS_RD pin):

General Purpose IO4 pin. Also used for BUS_RD signal to read and latch the data into the parallel GPIO BUS0..BUS7.

IO5/BUS_WR pin (GPIO IO5 or BUS_WR pin):

General Purpose IO5 pin. Also used for BUS_WR signal to write and latch the data to the parallel GPIO BUS0..BUS7.

BUS0-BUS7 pins (GPIO 8-Bit Bus):

8-bit parallel General purpose I/O Bus.

 **Note**

All GPIO pins are 5.0V tolerant.

5.3. System Pins

+5V (Module Voltage Input):**H1 pin 14, H2 pin 10:**

Module supply voltage input pin. This pin must be connected to a regulated supply voltage in the range of 4.0 Volts to 5.5 Volts DC. The nominal operating voltage is 5.0 Volts.

3.3V Out (3.3V Regulated Output):**H1 pin 22:**

External circuitry that requires a regulated 3.3V supply can be powered up via this pin. The maximum available current is 20mA.

GND (Module Ground):**H1 pin 11/13, H2 pin 4:**

Device ground pins. These pins must be connected to the ground.

RESET (Module Master Reset):**H1 pin 20, H2 pin 2:**

Module Master Reset pin. An active low pulse of greater than 2 μ s will reset the module. Internally pulled up to 3.3V via a 10K resistor. Only use open collector-type circuits to reset the device if an external reset is required.

AUDENB (Audio Enable Output):**H1 pin 18:**

Output dedicated to enabling or disabling an external audio amplifier (if required).

AUDIO (Audio Line Level Output):

H1 pin 16:

Line Level output specifically for Audio. This pin is for connecting to an external amplifier. When used in conjunction with AUDENB this pin can be used as a line-level output (AUDENB enabled is LOW) to drive an external amplifier.

5.4. VGA Output Header and Pads

The uVGA-III features a remote VGA connector, which can be disconnected from the PCB. The remote VGA connector enables flexible mounting and connection options when using the uVGA-III.

 **Note**

The orientation of the VGA cable onto the PCB is important. The striped wire on the VGA cable indicates **Pin 10** on Header J3.

Extra Video Out pads are provided on the rear of the PCB (J4), for added flexibility and wiring options.

 **Note**

The extra Video Out pads (J4) are a mirror image to the header on the front of the PCB (J3), so the supplied VGA cable [cannot] simply be plugged in if a header is attached.

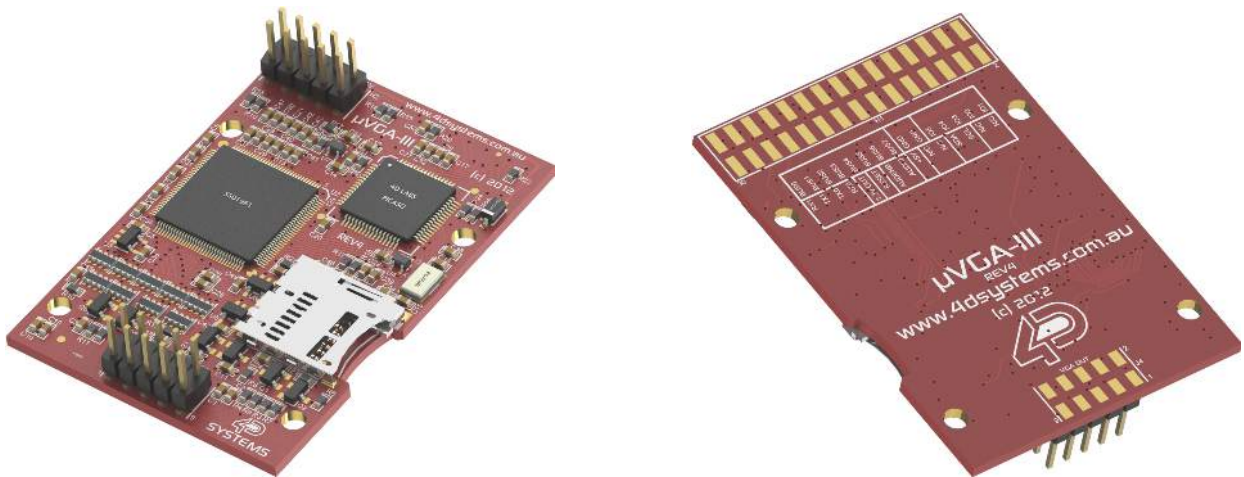

6. Firmware / PmmC Programming

The PICASO processor used in the uVGA-III module is a custom graphics controller. All functionality including the high level commands are built into the chip. This chip-level configuration is available as a Firmware/PmmC (Personality-module-micro-Code) file.

A PmmC file contains all of the low-level micro-code information (analogy of that of a soft silicon) which defines the characteristics and functionality of the device. The ability to program the device with a PmmC file provides an extremely flexible method of customising as well as upgrading it with future enhancements.

A PmmC file can only be programmed into the device via its COM0 serial port. The figure below provides a typical implementation for the PmmC programming interface.

The PmmC file is programmed into the device with the aid of Workshop4, the 4D Systems IDE software (See Section 9). To provide a link between the PC and the ICSP interface, a specific 4D Programming Cable is required and is available from 4D Systems.

Using a non-4D programming interface could damage your display, and **void your Warranty.**

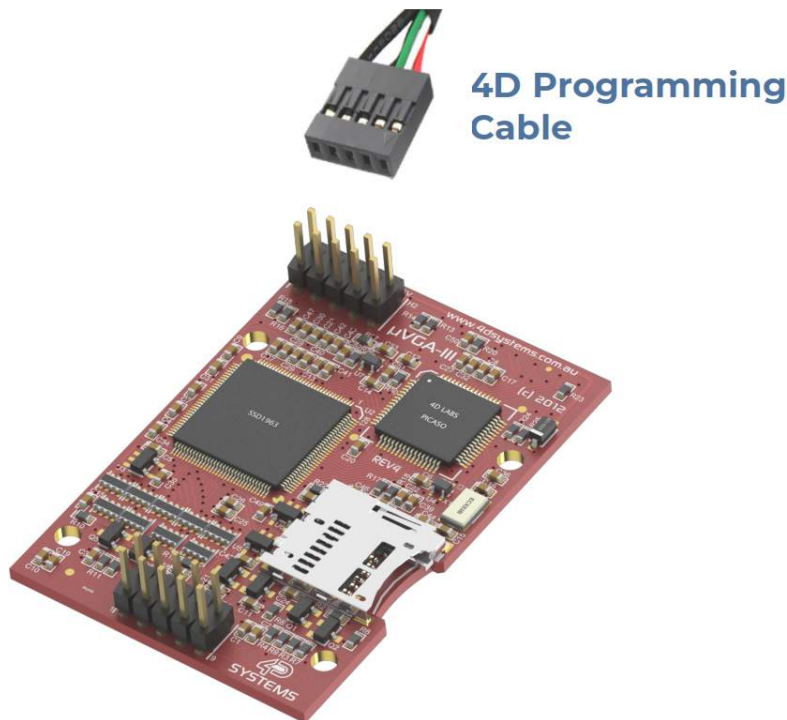

7. Module Features

The uVGA-III module is designed to accommodate most applications. Some of the main features of the module are listed below.

7.1. VGA - Interface

The uVGA-III module can be interfaced with a VGA Monitor or a screen with a VGA interface. The VGA interface consists of R, G, B, Vsync, Hsync and Clock signals.

The display resolution should match the uVGA-III resolution. If the display supports multiple resolutions then set it to "Auto detect" or manually set the resolution to match the module. The following VGA resolutions are supported:

- 320 x 240
- 640 x 480
- 800 x 480

7.2. PICASO Processor

The module is designed around the PICASO Graphics Processor from 4D-Labs.

The PICASO is a smart Controller and the interface to the TFT-LCD displays is almost plug-n-play.



All of the data and control signals are provided by the chip to interface directly with the display.

Powerful graphics, text, images, animation and countless more features are built right inside the chip.

For more information read the [Picaso Processor](#) datasheet.

7.3. Audio

Audio playback support in the PICASO Processor enables the uVGA-III module to play WAV audio at Line Levels to a pin on the expansion header. A simple instruction enables the user to play/pause/stop audio files while continuing the execution of the user's code, such as display updates, touch recognition, communications, etc. The audio system also allows real-time pitch change of audio samples.

For a complete list of audio commands please refer to the [Picaso 4DGL Internal Functions](#)

7.4. SD/SDHC Memory Cards

The module supports micro-SD memory cards via the onboard latch-type micro-SD connector. The memory card is used for all multimedia file retrieval such as images, animations and movie clips. The memory card can also be used as general-purpose storage for data logging applications. Support is available for off-the-shelf micro-SD (< 4GB) and high-capacity HC memory cards (4GB and above). Memory cards up to 32GB in size can be used, however, it must be noted that only a portion of this can be used by the FAT16 file system. See the **FAT16** section below for more details.



 **Note**

A microSD card capable of SPI is a requirement for all 4D Systems' display modules powered by Goldelox, Picaso or Diablo16 Processors. If a non-SPI compatible card is used, it will simply fail to mount, or may cause intermittent issues resulting in lockups and crashing of the application. Please refer to the 4D Systems website for microSD cards offered by 4D Systems.

7.5. FAT16

The uVGA-III uses off-the-shelf standard SDHC/SD/micro-SD memory cards with up to 2GB capacity usable with FAT16 formatting. For any FAT file-related operations, before the memory card can be used it must first be formatted with the FAT16 option. The formatting of the card can be done on any PC system with a card reader. Select the appropriate drive and choose the FAT16 (or just FAT in some systems) option when formatting. The card is now ready to be used in the PICASO-based application.

The uVGA-III also supports high-capacity HC memory cards (4GB and above). The available capacity of SD-HC cards varies according to the way the card is partitioned and the commands used to access it.

The FAT partition is always first (if it exists) and can be up to the maximum size permitted by FAT16. Windows 7 will format FAT16 up to 4GB. Windows XP will format FAT16 up to 2GB and the Windows XP command prompt will format FAT16 up to 4GB.

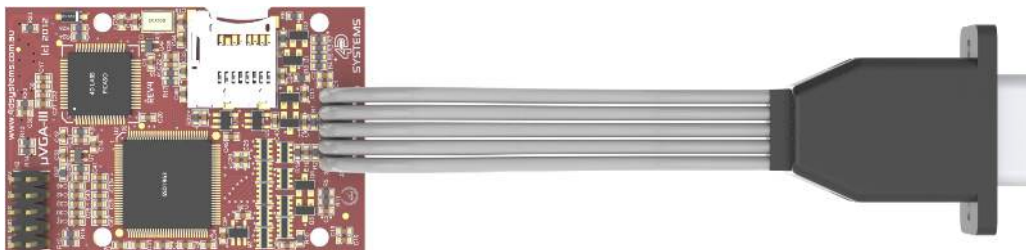

8. Hardware Tools

The following hardware tools are required for full control of the uVGA-III module.

8.1. Programming Cable/Adaptor

The 4D Programming Cable and uUSB-PA5 Programming Adaptor are essential hardware tools to program, customise and test the PICASO Processor.

Either the 4D Programming Cable or the uUSB-PA5 Programming Adaptor can be used.

The 4D programming interfaces are used to program a new Firmware/PmmC and for downloading compiled 4DGL code into the processor. They even serve as an interface for communicating serial data to the PC.

The 4D Programming Cable and uUSB-PA5 Programming Adaptor are available from the [4D Systems website](#).

Using a non-4D programming interface could damage your processor, and **void your Warranty**



4D Programming Cable



uUSB-PA5-II Programming Adaptor

9. Programming Language

The DIABLO16 processor belongs to a family of processors powered by a highly optimised softcore virtual engine called EVE (Extensible Virtual Engine). EVE was designed and created by 4D Systems in the early 2000's, and should not be confused with FTDI's solution of EVE, which was developed a decent decade or so later.

EVE is a proprietary, high-performance virtual machine with an extensive byte-code instruction set optimised to execute compiled 4DGL programs.

4DGL (4D Graphics Language) was specifically developed from ground up for the EVE engine core. It is a high-level language which is easy to learn and simple to understand yet powerful enough to tackle many embedded graphics applications.

4DGL is a graphics-oriented language allowing rapid application development, and the syntax structure was designed using elements of popular languages such as C, Basic, Pascal and others.

Programmers familiar with these languages will feel right at home with 4DGL. It includes many familiar instructions such as `IF..ELSE..ENDIF`, `WHILE..WEND`, `REPEAT..UNTIL`, `GOSUB..ENDSUB`, `GOTO`, `PRINT` as well as some specialised instructions `SERIN`, `SEROUT`, `GFX_LINE`, `GFX_CIRCLE` and many more.

For detailed information about the 4DGL language, please refer to the following documents:

- [4DGL Programmers Reference Manual](#)
- [Goldelox Internal Functions Manual](#)

To assist with the development of 4DGL applications, the Workshop4 IDE combines a full-featured editor, a compiler, a linker and a downloader into a single PC-based application. It's all you need to code, test and run your applications.

4DGL is available to be written in two of the four environments offered by the Workshop4 IDE, Designer and ViSi. The other two environments, Serial and ViSi-Genie do not directly use 4DGL by the User (Except in Workshop4 Pro, for ViSi-Genie), however, it is present in the background. Serial is an application that runs, and that is written in 4DGL. ViSi-Genie automatically generates 4DGL itself based on what is configured in the GUI.

10. Workshop4 IDE

Workshop4 is a comprehensive software IDE that provides an integrated software development platform for all of the 4D family of processors and modules. The IDE combines the Editor, Compiler, Linker and Downloader to develop complete 4DGL application code. All user application code is developed within the Workshop4 IDE.



The Workshop4 IDE supports multiple development environments for the user, to cater to different user requirements and skill levels.

- The **Designer** environment enables the user to write 4DGL code in its natural form to program the range of 4D Systems' intelligent displays.
- A visual programming experience, suitably called **Visi**, enables drag-and-drop type placement of objects to assist with 4DGL code generation and allows the user to visualise how the display will look while being developed.
- An advanced environment called **Visi-Genie** doesn't require any 4DGL coding at all, it is all done automatically for you. Simply lay the display out with the objects you want, set the events to drive them and the code is written for you automatically. This can be extended with additional features when a Workshop4 PRO license is purchased from the 4D Systems website. Extended Advanced features for Visi-Genie are available in the PRO version of WS4. Further details are explained under the [Visi Genie](#) section of the Workshop4 documentation.
- A **Serial** environment (aka SPE 'Serial Platform Environment') is also provided to transform the display module into a slave serial module, allowing the user to control the display from any host microcontroller or device with a serial port using predefined serial commands.

For more information regarding these environments, refer to the [Workshop4 manuals](#).

The Workshop4 IDE is available from the [4D Systems website](#).

11. Mechanical Details

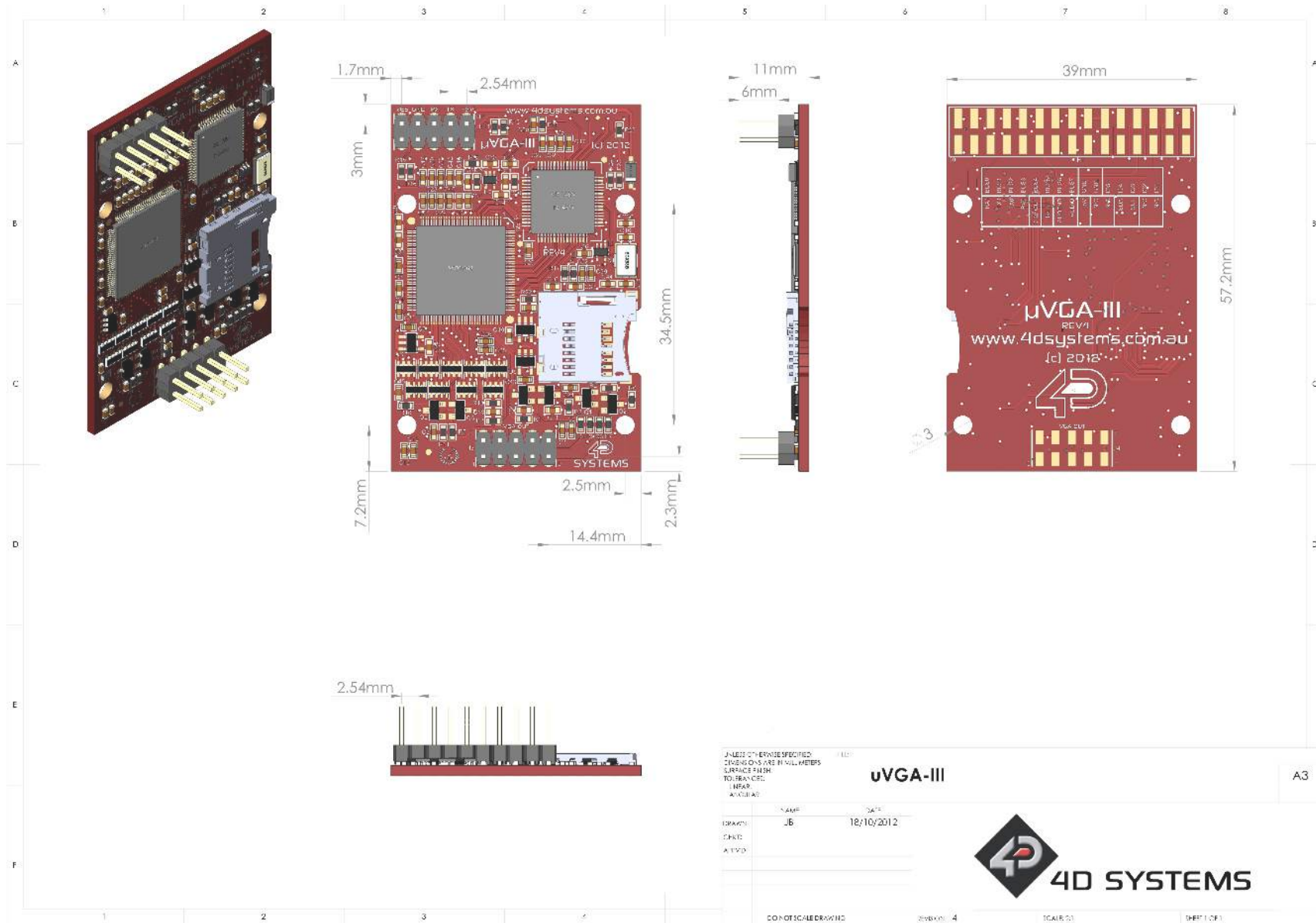

12. Schematic Diagram

12.1. Sheet 1

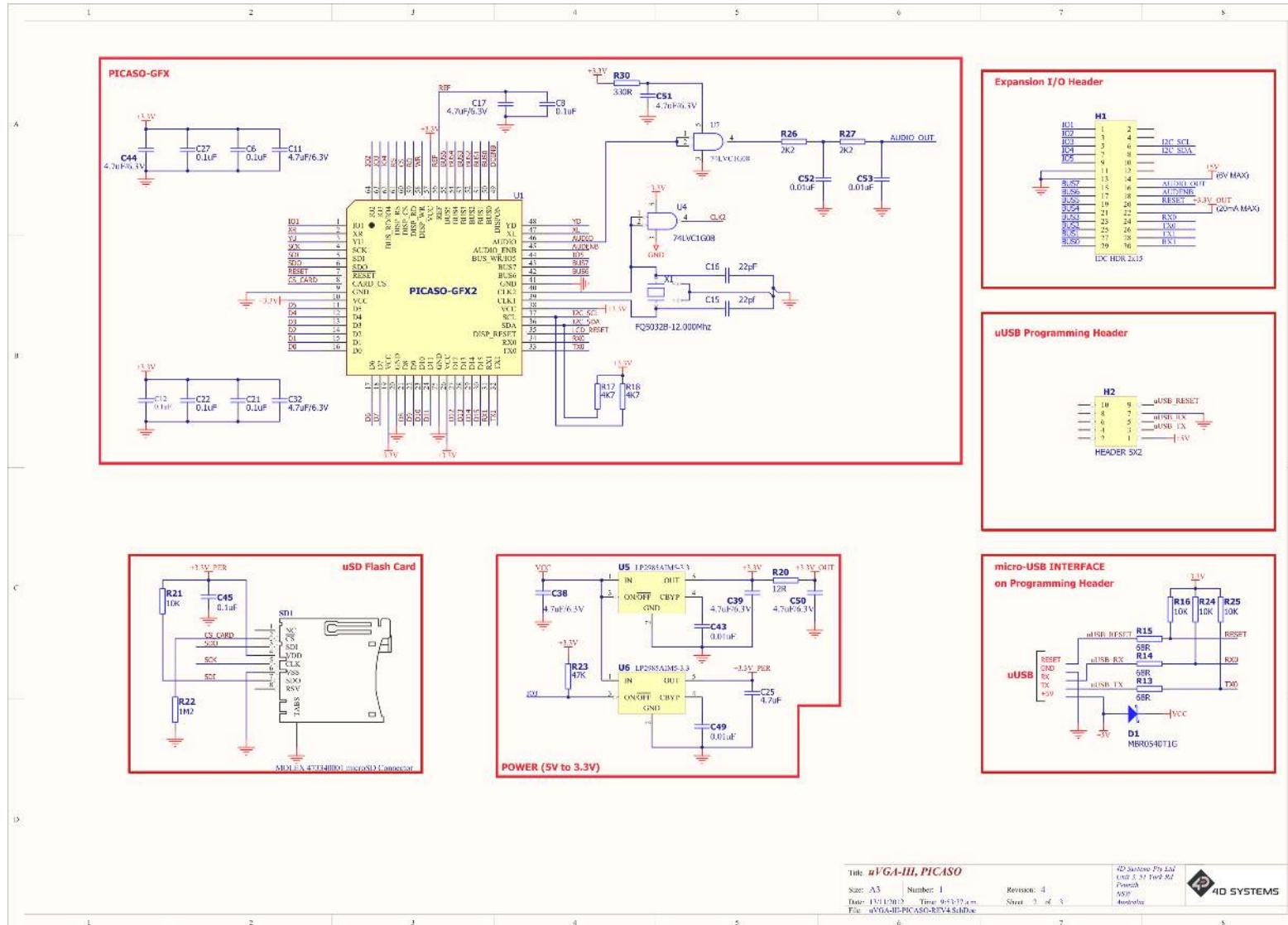

12.2. Sheet 2

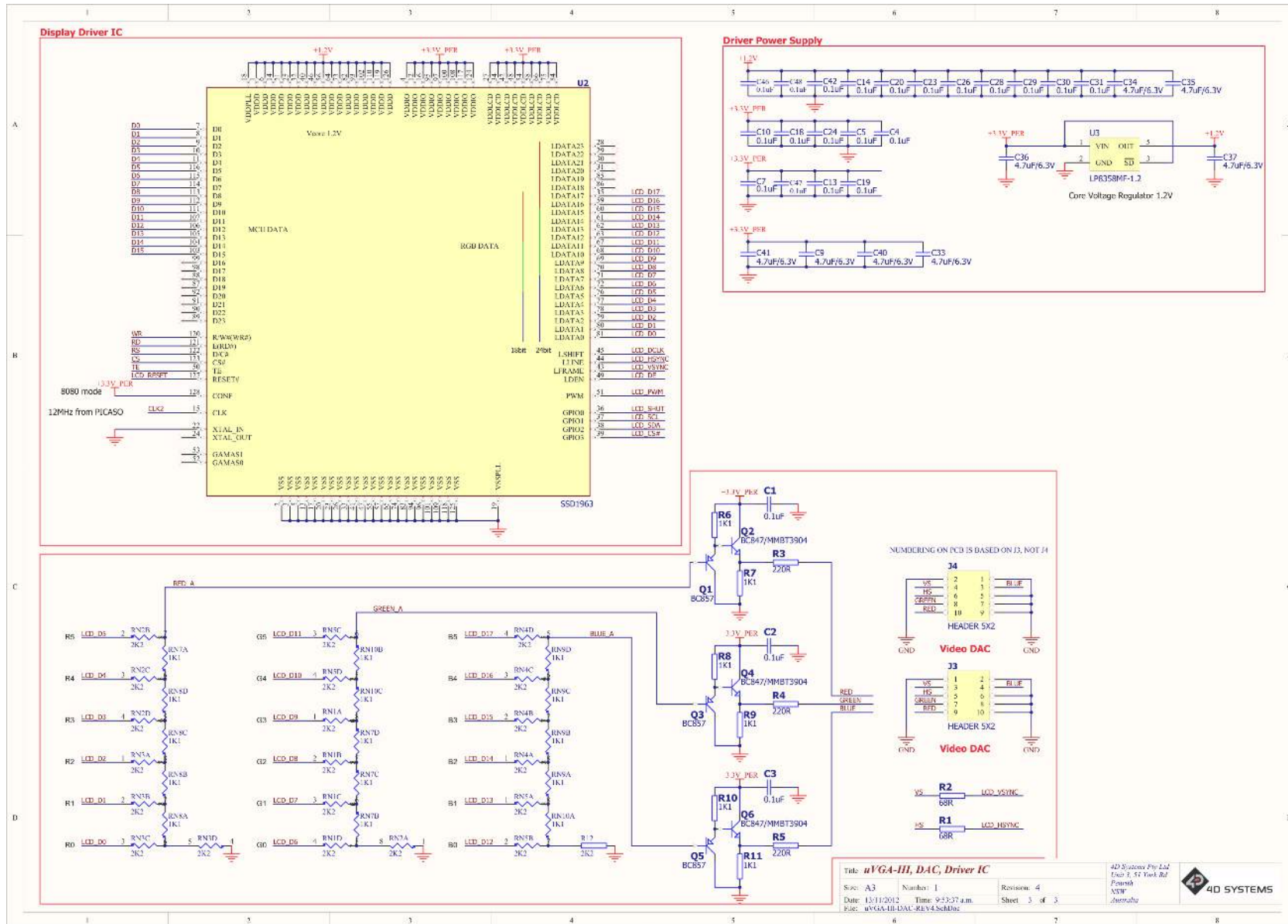

Title: uVGA-III, DAC, Driver IC
 Size: A3 Number: 1 Revision: 4
 Date: 13/11/2012 Time: 9:53:37 a.m. Sheet: 5 of 5
 File: uVGA-III-DAC-REV4.SchDoc

4D Systems Pty Ltd
 Unit 3, 51 York Rd
 Perth
 WA
 Australia

4D SYSTEMS

13. Specifications

Absolute Maximum Ratings

Operating ambient temperature	-20°C to +70°C
Storage temperature	-30°C to +80°C
Voltage on any digital input pin with respect to GND	-0.3V to 6.0V
Voltage on SWITCH pin with respect to GND	-0.3V to 6.0V
Voltage on VCC with respect to GND	-0.3V to 6.0V

Note

Stresses above those listed here may cause permanent damage to the device. This is a stress rating only and functional operation of the device at those or any other conditions above those indicated in the recommended operation listings of this specification is not implied. Exposure to maximum rating conditions for extended periods may affect device reliability.

Recommended Operating Conditions

Parameter	Conditions	Min	Typ	Max	Units
Supply Voltage (VCC)		4.0	5.0	5.5	V
Processor voltage (VP)		--	3.3	--	V
Operating Temperature		-10	--	+60	°C
Input Low Voltage (VIL)	all pins	0	--	0.2VP	V
Input High Voltage (VIH)	non 5V tolerant pins	0.8VP	--	3.3	V
Input High Voltage (VIH)	All GPIO pins, RX0 and TX0 pins	0.8VP	--	5.5	V
Reset Pulse	External Open Collector	2.0	--	--	µs
Operational Delay	Power-Up or External Reset	500	--	3000	ms

Global Characteristics Based on Operating Conditions

Parameter	Conditions	Min	Typ	Max	Units
Supply Current (ICC)	VCC = 5.0V, heavily depends on screen usage conditions, sleep mode	20	100	120	mA
Output Low Voltage (VOL)	VCC = 5.0V, IOL = 3.4mA	--	--	0.4	V
Output High Voltage (VOH)	VCC = 5.0V, IOL = -2.0mA	2.4	--	--	V
Capacitive Loading	All pins	--	--	50	pF
Flash Memory Endurance	PICASO PmmC Programming	--	10000	--	E/W

Ordering Information

Order Code: uVGA-III

Package: 65mm x 50mm x 30mm

Packaging: Module sealed in antistatic foam padded 4D Systems Box

14. Revision History

Hardware Revision

Revision Number	Date	Description
2.01	14/06/2013	Initial Public Release Version

Datasheet Revision

Revision Number	Date	Description
1.3	14/06/2013	Initial Public Release Version
1.4	04/03/2019	Cosmetic changes, removed clutters
1.8	13/01/2023	Modified datasheet for web-based documentation