

REVISIONS					
P	LTR	DESCRIPTION	DATE	DMN	APVD
C		REV PER ECO 20-006653	5-15-20	CT	DM

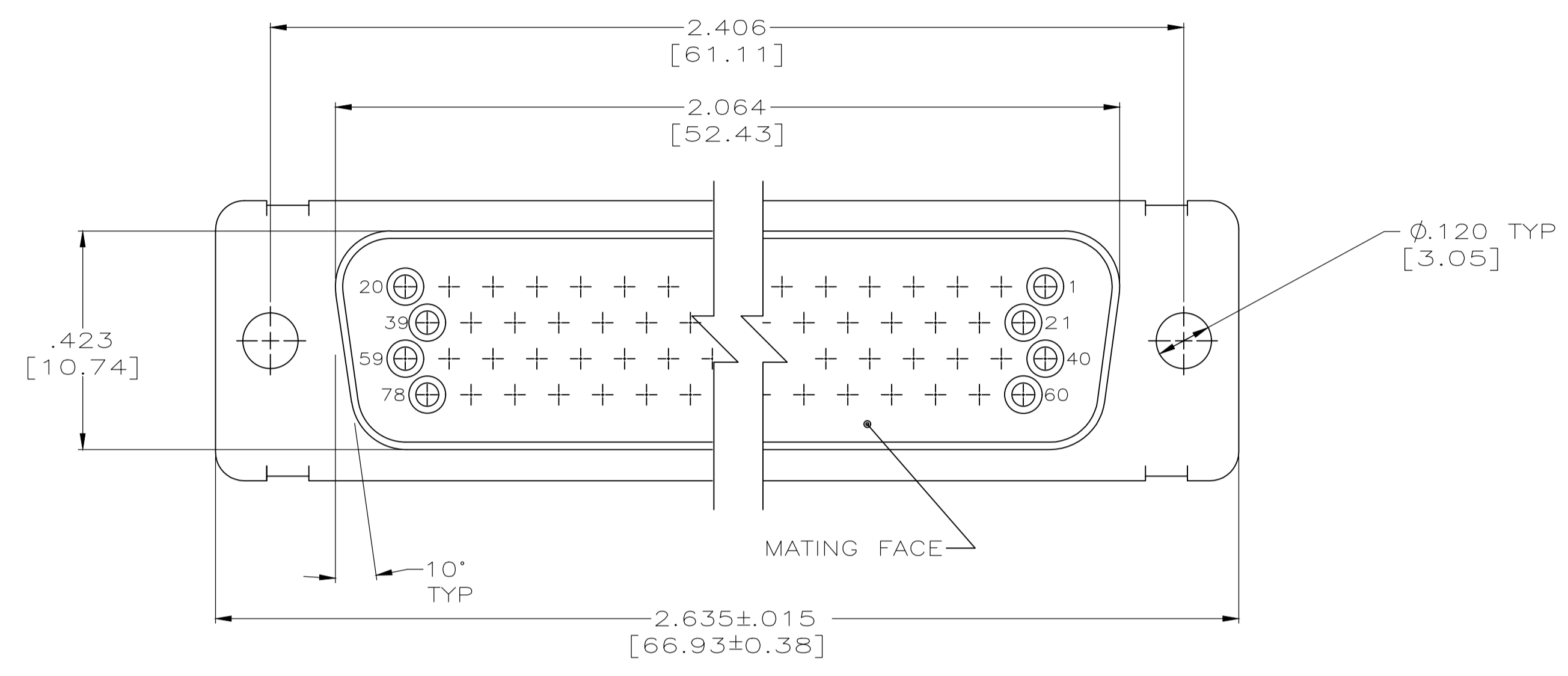

- ⚠ MARKED WITH .047 [1.19] HIGH CHARACTERS. FAR SIDE REFERS TO WIDE SIDE OF KEYSTONE, NEAR SIDE REFERS TO NARROW SIDE OF KEYSTONE.
- ⚠ STAINLESS STEEL RETENTION CLIPS ARE INCLUDED IN INSERTS.
- 3. THIS RECEPTACLE WILL MATE WITH ANY PLUG CONNECTOR WITH THE SAME INSERT ARRANGEMENT.
- ⚠ MAXIMUM WIRE INSULATION USED WITH THIS CONNECTOR IS .054 [1.37] DIAMETER WITH GROMMET
- ⚠ CONTACTS ARE PACKAGED SEPARATELY AND SHIPPED WITH CONNECTOR.

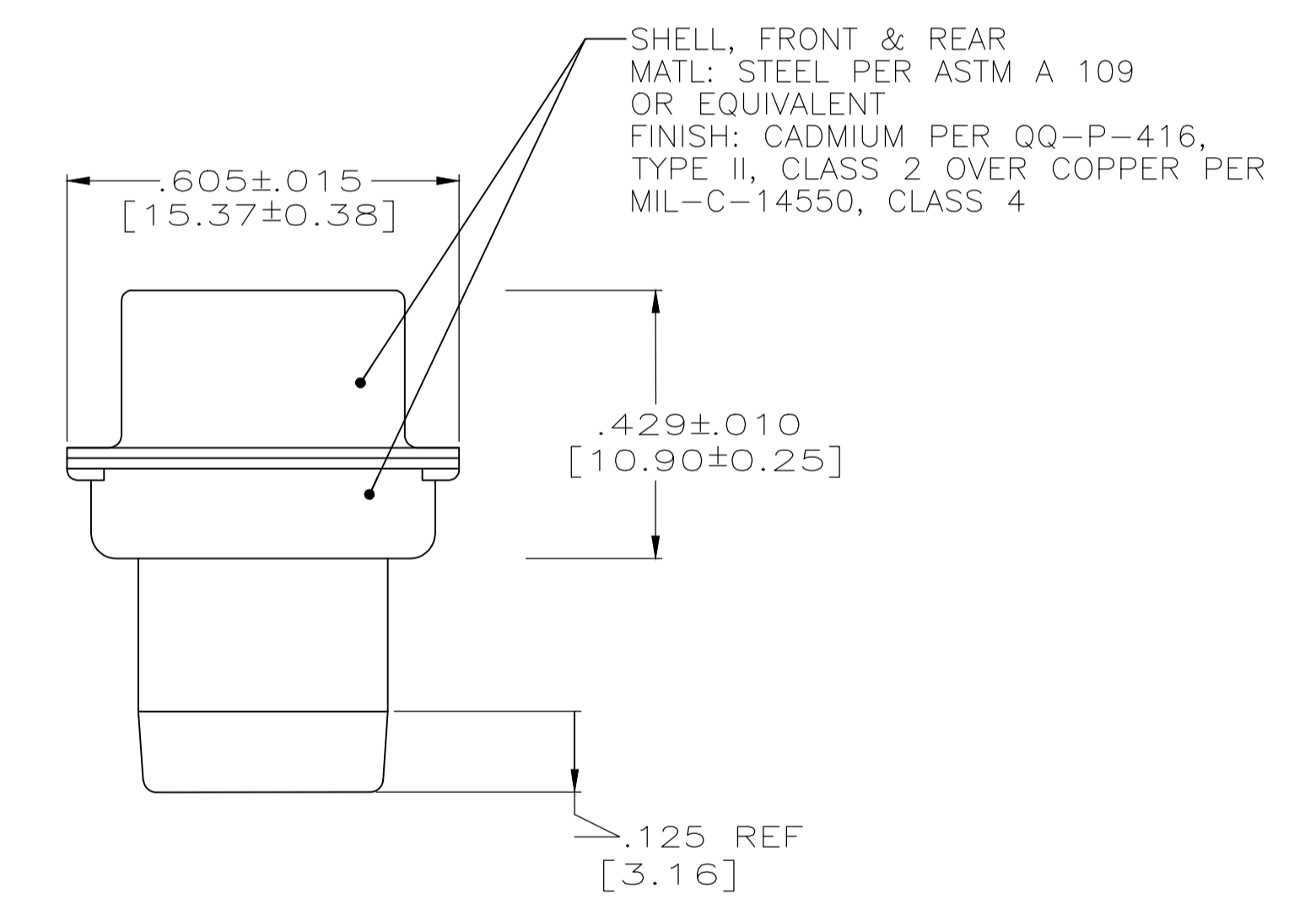
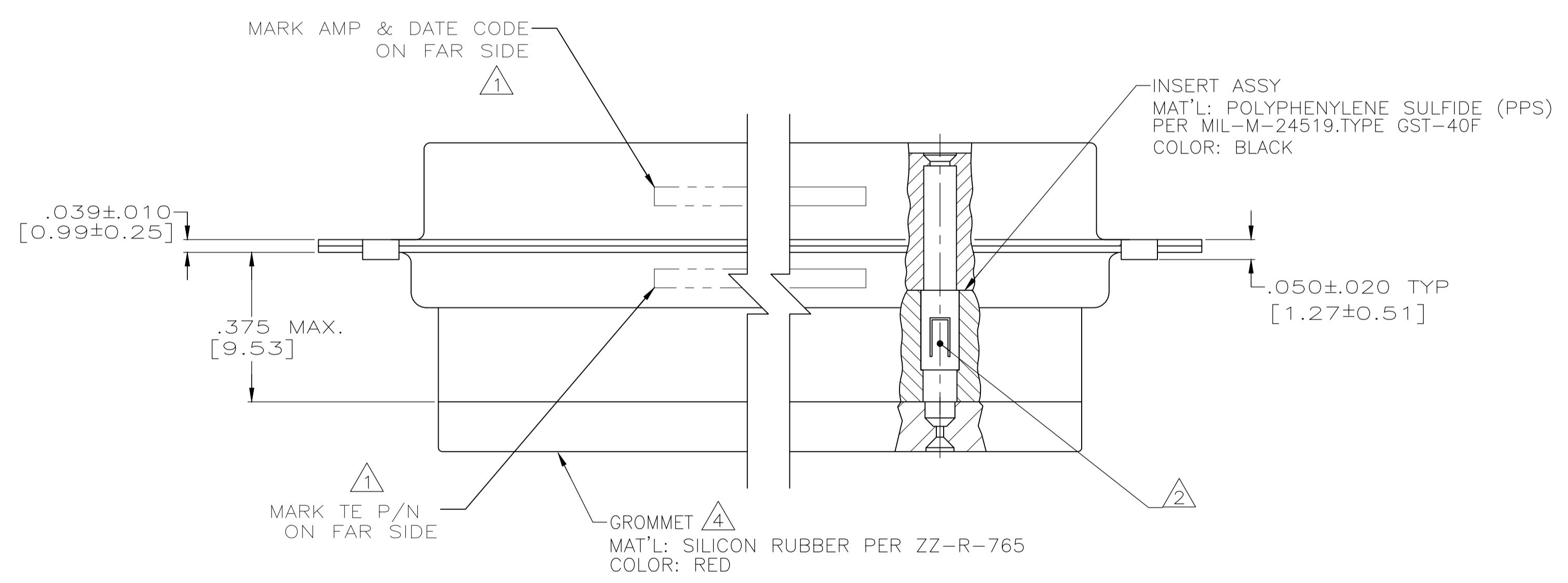

SIZE 22D SOCKET CONTACT (QTY=78)  
 MAT'L: BODY- COPPER ALLOY  
 SLEEVE- STAINLESS STEEL  
 FINISH: BODY- GOLD PLATED PER MIL-G-45204 OVER NICKEL PER QQ-N-290  
 SLEEVE- PASSIVATED PER QQ-P-35

1218535-1  
 PART NO.

THIS DRAWING IS A CONTROLLED DOCUMENT.		DMN C.C.THOMAS 9/23/99	TE Connectivity	
DIMENSIONS: INCHES		CHK CHAD BAKER 10-5-99		
TOLERANCES UNLESS OTHERWISE SPECIFIED:		APVD CHAD BAKER 10-5-99	NAME RCPT ASSY, SIZE 5,78 POSN., SERIES 90,AMPLIMITE	
0. PLC ± -	1. PLC ± -	PRODUCT SPEC	APPLICATION SPEC	
2. PLC ± -	3. PLC ± .005 [0.13]	SIZE	CAGE CODE	DRAWING NO
4. PLC ± -	ANGLES ± -	WEIGHT	A1 00779	1218535
MATERIAL SEE CALLOUTS	FINISH SEE CALLOUTS	CUSTOMER DRAWING	SCALE 4:1	SHEET 1 OF 1