

REVISIONS			
REV	ECN, ERN NO.	DATE	APPRD.
A	PRODUCT DRAWING (EAR 13448)	JAN15/09	L.C.
B	PRODUCT DRAWING (EAR 14867)	NOV18/20	K.L.

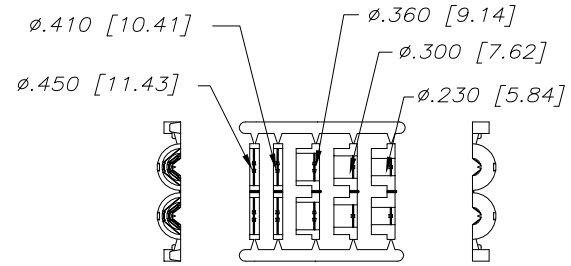

JACKET INSERT TREE

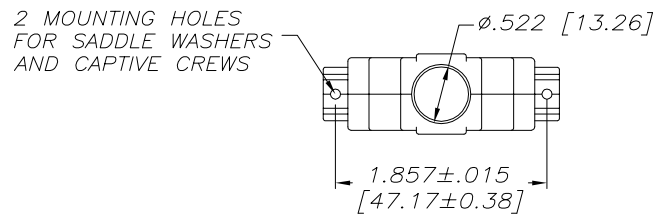

CONNECTOR BACKSHELL

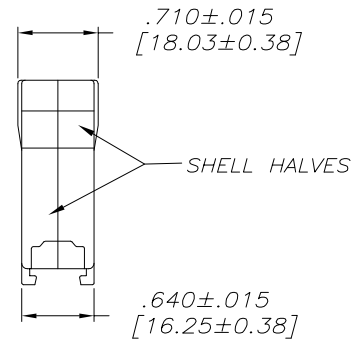
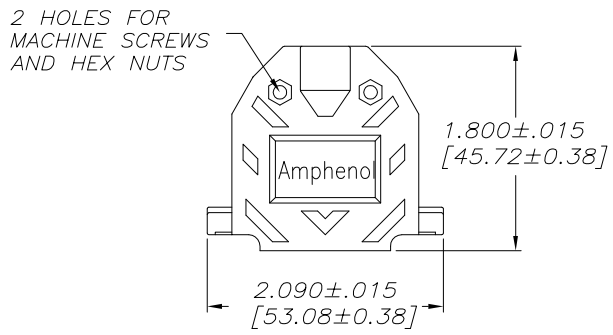

SHELL HALVES

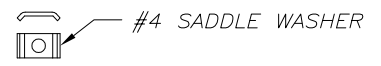
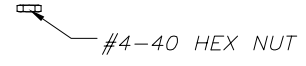
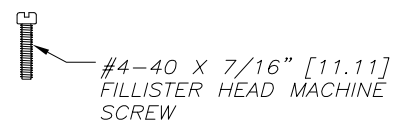

NOTES:

- 1) EACH BACKSHELL KIT CONTAINS 2 SHELL HALVES, 1 JACKET INSERT TREE AND 2 OF EACH HARDWARE ITEM SHOWN.
- 2) BACKSHELL IS SUITABLE FOR SUBMINIATURE D CONNECTOR, B SIZE SHELL (25 POSITION STANDARD CONTACTS OR 44 POSITION HIGH DENSITY CONTACTS).
- 3) JACKET INSERTS ARE DESIGNED FOR A CABLE DIAMETER RANGE OF .230 [5.84] TO .450 [11.43]. REMOVE THE SUITABLE INSERT FROM THE TREE AND INSTALL IT INTO THE CABLE CLAMP PORTION OF THE BACKSHELL.
- 4) MATERIALS - ALL MATERIALS ARE RoHS COMPLIANT
 SHELL - THERMOPLASTIC, UL FLAMMABILITY RATING UL94V-0, BLACK, TOLERANCE: ±.015 [0.38]
 INSERT TREE - POLYPROPYLENE HOMOPOLYMER, BLACK, TOLERANCE: ±.010 [0.25]
 HARDWARE - STEEL, ZINC PLATED, TRIVALENT CHROMATE FINISH



THIS DOCUMENT CONTAINS PROPRIETARY INFORMATION AND SUCH INFORMATION MAY NOT BE DISCLOSED TO OTHERS FOR ANY PURPOSE OR USED FOR MANUFACTURING PURPOSES WITHOUT WRITTEN PERMISSION FROM AMPHENOL CANADA CORP.

DRAWN	DAVIE.W	DATE	JAN14/09	Amphenol Canada Corp.		
DESIGNED						
CHECKED	L. CHAN	DATE	JAN15/09	17E SERIES D-SUB CONNECTOR BACKSHELL, B SIZE SHELL (25 STD OR 44 HD CONTACTS) 2 PIECE, PLASTIC, STRAIGHT EXIT, #4-40 THREAD, RoHS COMPLIANT		
I. E. APPRD.						
Q. A. APPRD.						
DWG. APPRD.						
ENG. REL. NO.	EAR 13448	DWG	DRAWING NO.	P-17E-1726-1	REV.	B
REF.		C				
DIMENSIONS ARE IN INCHES [mm]	CODE ID. NO. 03554	SCALE	1/1	WT.	SURF.	SHEET 1 OF 1