

PART NUMBER	REV	FIRST USED
567944 -1	A	854040-3

TERMINAL NAME: DDC TYPE CONNECTOR (CRIMP DATA PER CUSTOMER SPEC)					
WIRE STRIP LENGTH	TERM APPL SPEC	FEED	APPL INSTRUCTION	SET UP GAGE	LAYOUT
CRIMPING DATA					
VISIBLE PAD LTR					
CRIMP HEIGHT			WIRE SIZE		
A	.045 ± .002 [1.14 ± 0.05mm]	0.75mm ²			
B	.041 ± .002 [1.04 ± 0.05mm]	0.5mm ²			
C	NOT	USED			
D	NOT	USED			
CRIMP		SIZE	TYPE	RANGE	
WIRE	.076 [1.93mm]	F	0.5-0.75mm ²		
INSUL	.102 [2.59mm]	F	ø2.29mm MAX		

SIM TO HDM 680191 AND CQM SCA 567858					
					70
					69
					68
					67
					66
					65
					64
					63
					62
					61
					60
					59
					58
					57
					56
					55
					54
					53
					52
					51
					50
					49
					48
					47
					46
					45
					44
					43
					42
					41
					40
					39
					38
					37
					36
					35
					34
					33
					32
					31
					30
					29
					28
					27
					26
					25
					24
					23
					22
					21
					20
					19
					18
					17
					16
					15
					14
					13
					12
					11
					10
					9
					8
					7
					6
					5
					4
					3
					2
					1

THIS DRAWING IS A CONTROLLED DOCUMENT FOR AMP INCORPORATED. IT IS SUBJECT TO CHANGE AND THE CONTROLLING ENGINEERING ORGANIZATION SHOULD BE CONTACTED FOR THE LATEST REVISION.

THIS INFORMATION IS CONFIDENTIAL AND IS DISCLOSED TO YOU ON CONDITION THAT NO FURTHER DISCLOSURE IS MADE BY YOU TO OTHER THAN AMP PERSONNEL WITHOUT WRITTEN AUTHORIZATION FROM AMP INCORPORATED, HARRISBURG, PA.

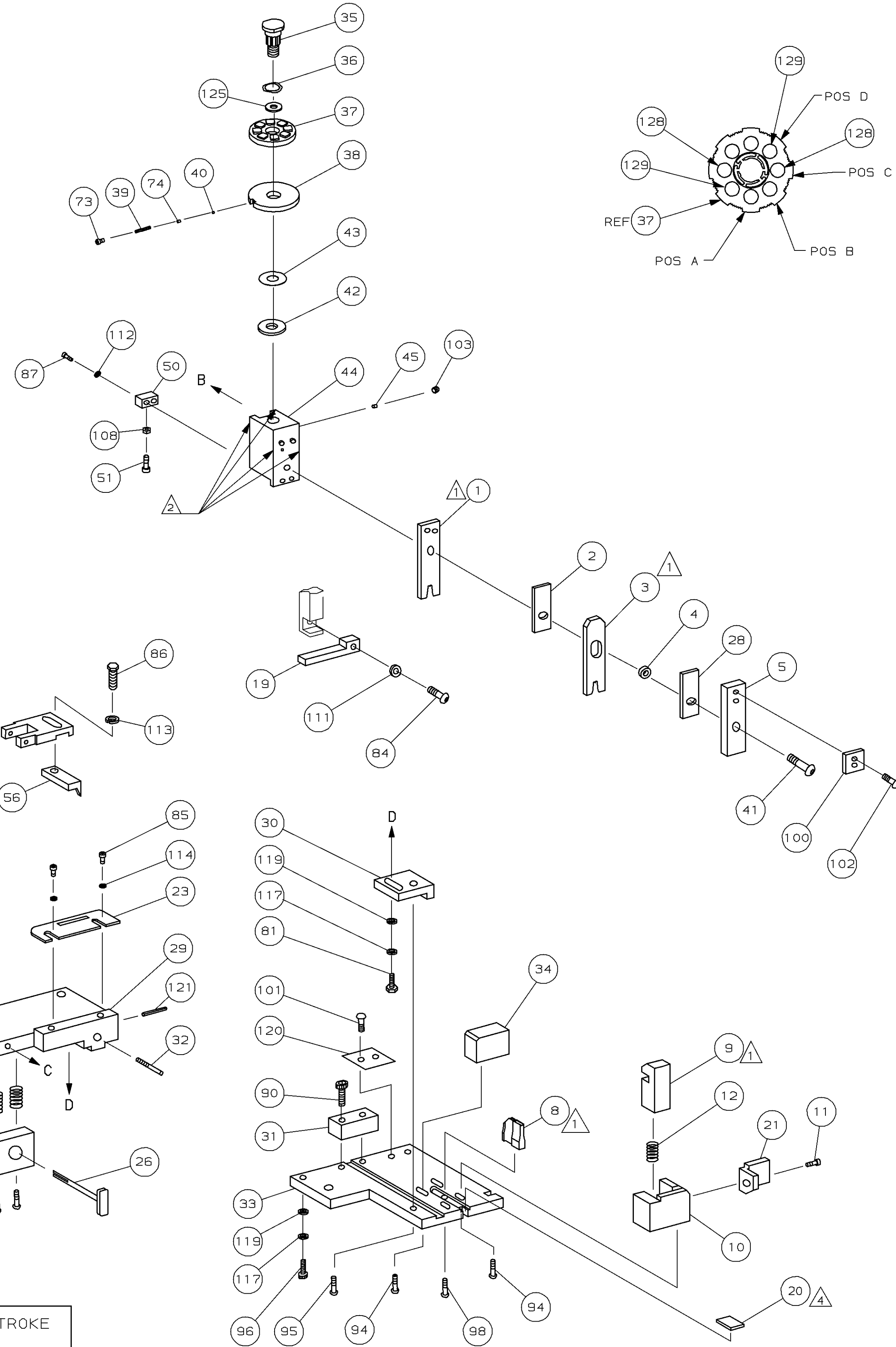

QTY	REV	U/M	DWG SIZE	PART NO	DESCRIPTION	ITEM NO
2	-	C		5-354779-4	PIN, WIRE DISC (.3260) D	129
2	-	C		4-354779-6	PIN, WIRE DISC (.3220) C	128
						127
						126
1	-	A		986950-1	WASHER, FLAT PRECISION	125
1	-	A		217238-3	GENERAL INSTRUCTION PACKAGE	124
						123
						122
1	-	A		4-21028-0	PIN, SLT SPR (ø.093x.75) ST GDE PL	121
1	-	B		690701-2	PLATE, SERIAL NO.	120
2	-	A		21899-2	WASHER, FLAT (#10) S G ADJ BLK	119
						118
2	-	A		21024-5	WASHER, LOCK (#10) ADJ BLOCK	117
						116
						115
2	-	A		21024-2	WASHER, LOCK (#4) FRONT STP GUIDE	114
REF	-	A		21024-4	WASHER, LOCK (#8) FEED FINGER	113
2	-	A		21024-4	WASHER, LOCK (#8) DEP-HOLD	112
REF	-	A		21024-4	WASHER, LOCK (#8) STRIPPER	111
						110
						109
1	-	A		21018-5	NUT, HEX (#6) HOLD DOWN	108
						107
						106
						105
						104
1	-	A		21009-2	SCR, SKT SET (1/4-20x.25 LW) RAM	103
2	-	A		21017-1	SCR, DRIVE (#2x.12) ID PLATE	102
2	-	A		21017-2	SCR, DRIVE (#2x.19) ID PLATE	101
1	-	B		819347-1	PLATE, IDENTIFICATION	100
2	-	A		3-21002-0	SCR, BHC (10-32x.88) DRAG	99
1	-	A		22733-8	SCR, BHC (8-32x.38 LW) ANVIL	98
						97
1	-	A		3-21000-8	SCR, SHC (10-32x.88) MOUNTING	96
1	-	A		2-21002-7	SCR, BHC (10-32x.50) S G ADJ BLK	95
6	-	A		2-21002-2	SCR, BHC (8-32x.50) SHEAR-TERM SUP	94
						93
						92
1	-	A		1-21002-7	SCR, SHC (6-32x.50) CAM	91
2	-	A		2-21000-7	SCR, SHC (8-32x.50) SCR BLK	90
						89
						88
2	-	A		2-21000-7	SCR, SHC (8-32x.48) DEP-HOLD DOWN	87
REF	-	A		2-22603-0	SCR, HEX HD (8-32x.31) FEED FINGER	86
2	-	A		1-21000-3	SCR, SHC (4-40x.25) F ST GUIDE	85
REF	-	A		22733-9	SCR, BHC (8-32x.50 SL) STRIPPER	84
						83
						82
1	-	A		3-22603-1	SCR, HEX (10-32x.38) S G ADJ BL	81
						80
						79
						78
2	-	B		463310-5	BLADE, STRIPPING (#20)	77
						76
						75
1	-	A		690603-1	SPRING, ASSIST	74
1	-	A		23030-1	SCR, SKT CAP (6-32x.25) CP DSC	73
						72
						71

QTY	REV	U/M	DWG SIZE	PART NO	DESCRIPTION	ITEM NO
1	-	A		463756-1	GUIDE, SCRAP	21
1	-	A		904275-1	SUPPORT, SPRING	20
REF	-	C		462615-1	STRIPPER	19
						18
						17
						16
						15
						14
						13
1	-	A		5-22280-0	SPRING, SHEAR	12
1	-	B		1-690461-6	STOP, SHEAR (FRONT)	11
1	-	B		462548-3	HOLDER, SHEAR (FRONT) SP	10
1	-	B		462547-3	SHEAR, FLOAT (FRONT) SP	9
1	-	C		1-662520-6	ANVIL	8
						7
						6
1	-	A		462838-3	DEPRESSOR, SHEAR (FRONT) SP	5
1	-	B		238011-6	SPACER, BLOCK CRIMPER	4
1	-	C		5-683453-5	CRIMPER, INSULATION	3
1	-	C		455888-9	SPACER, CRIMPER	2
1	-	C		3-568176-0	CRIMPER, WIRE	1

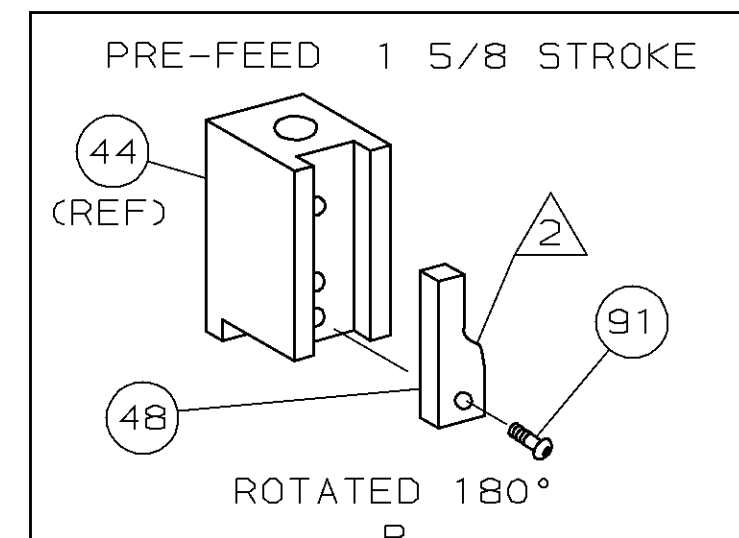

- 1 RECOMMENDED SPARE PARTS.
- 2 GREASE LIGHTLY.
- 3 ITEM NOT SHOWN
- 4 ATTACH ITEM 20 TO ITEM 33 USING ADHESIVE PART NUMBER 28998-6.
- 5 CUT TO LENGTH AT ASSY

LOC A
DIST 66

567944