

ORIGINAL



REVISIONS				
SYM	ECN No.	DESCRIPTION	DATE	APPROVED
A	NE-17299	RELEASE TO PRODUCTION	11/27/2017	Roger Tsai

This document is the property of Amphenol Corporation and is delivered on the express condition that is not to be disclosed, reproduced or used, in whole or in part, for manufacture or sale by anyone other than Amphenol Corporation without its prior consent, and that no right is granted to disclose or to use any information in this document.

The marking on this product doesn't contain environmental hazardous materials per Material Specification 55-00259 for Sony GP compliant or per directive 2011/65/EU for RoHS compliant.



PIN ASSIGNMENT

CONTACT NUMBER	SIGNAL NAME
1	VBUS
2	D-
3	D+
4	ID
5	GND
SHELL	SHIELD

- NOTES:**
- MATERIAL:**
HOUSING: HIGH TEMPERATURE THERMAL PLASTIC LCP, UL94V-0, COLOR: BLACK.
TERMINAL: COPPER ALLOY.
SHELL: STAINLESS STEEL.
 - FINISH:**
TERMINAL:
CONTACT AREA: SELECTIVE GOLD PLATING;
SOLDERING AREA: GOLD FLASH PLATING;
UNDER PLATING: NICKEL PLATING 50 μ" THICKNESS MIN. OVERALL.
SHELL:
MATTE TIN PLATING 80 μ" THICKNESS MIN.
UNDER PLATING: NICKEL PLATING 50 μ" THICKNESS MIN. OVERALL.
 - PRODUCT SPECIFICATION REFER TO : PS-7395
 - THIS PRODUCT DOESN'T CONTAIN ENVIRONMENTAL HAZARDOUS PER DIRECTIVE 2011/65/EU FOR RoHS COMPLIANT.

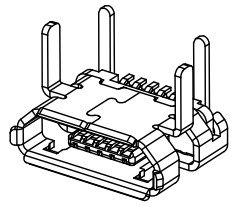
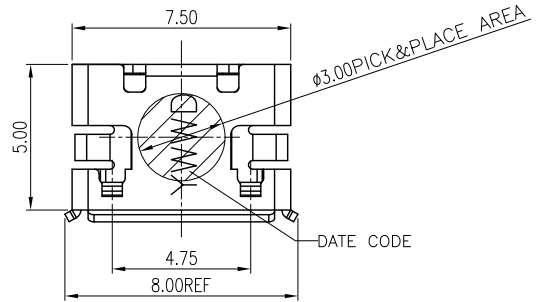

PART NUMBER:
GMCB 053 X 1123H1HR

- CONTACT FINISH
- 0: GOLD FLASH
 - 1: 15μ" GOLD
 - 2: 30μ" GOLD

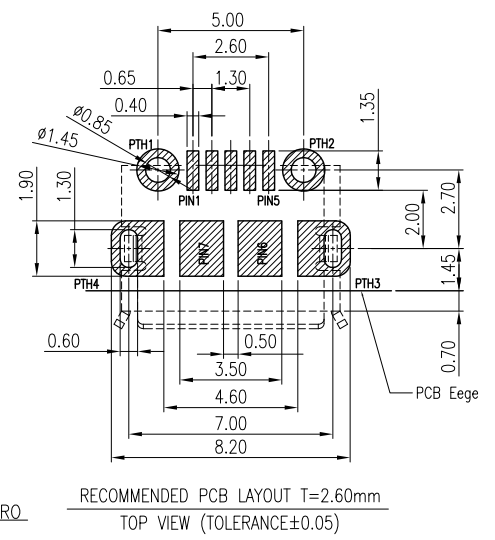
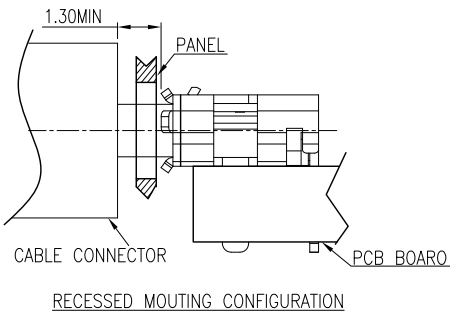
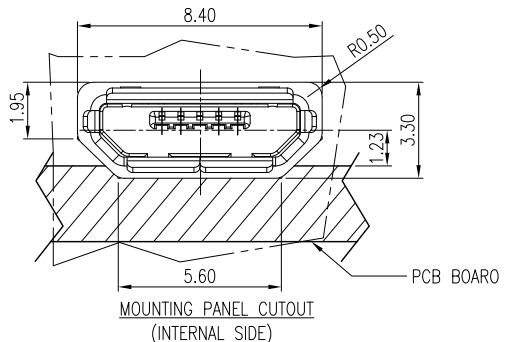
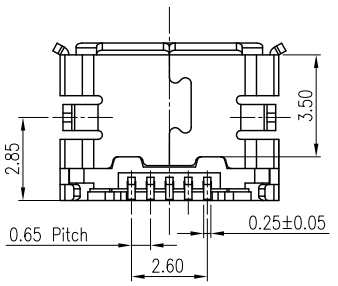
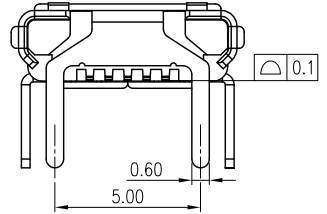
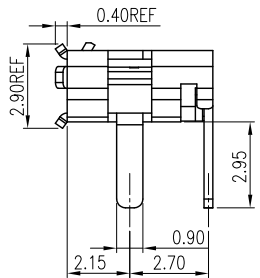
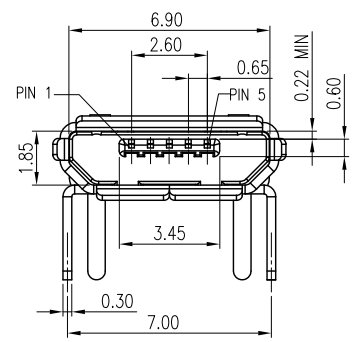

TOLERANCE	APPROVALS	DATE	TITLE		Amphenol®		
X. ±0.30	DRAWN Debby Hung	11/27/2017	MICRO USB, B TYPE 5 POS. RECEPTACLE, R/A SMT SHELL DIP 2.95mm		Amphenol Corporation Amphenol Taiwan Corporation		
X.X ±0.20	CHECKED Sandy Wu	11/27/2017					
X.XXX ±0.10	APPROVED Roger Tsai	11/27/2017	UNIT mm SIZE A3 PART No. GMCB053X1123H1HR		SHEET 1 OF 2 DWG No. GMCB053X1123H1HR REV. A		
ANGULAR ±1°	DWG TYPE CUST DWG	PROJECT CODE OTHER					
UNLESS OTHERWISE SPECIFIED			SCALE NA				

This document is the property of Amphenol Corporation and is delivered on the express condition that is not to be disclosed, reproduced or used, in whole or in part, for manufacture or sale by anyone other than Amphenol Corporation without its prior consent, and that no right is granted to disclose or to use any information in this document.

The marking on this product doesn't contain environmental hazardous materials per Material Specification 55-00259 for Sony GP compliant or per directive 2011/65/EU for RoHS compliant.



ORIGINAL



REVISIONS				
SYM	ECN No.	DESCRIPTION	DATE	APPROVED
A	NE-17299	RELEASE TO PRODUCTION	11/27/2017	Roger Tsai

PULL OUT DIRECTION →

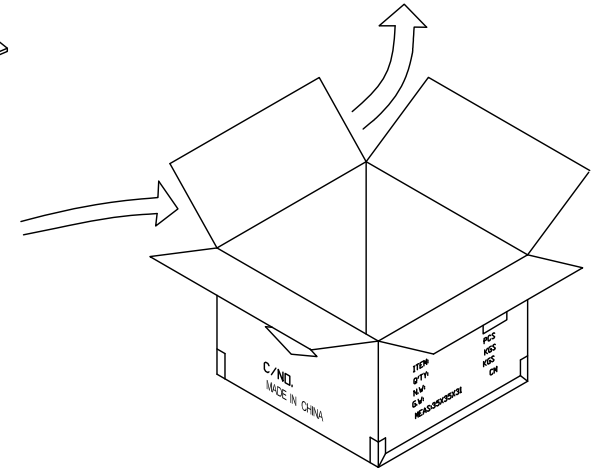
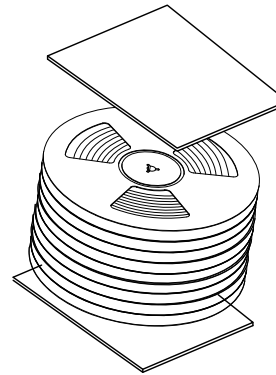
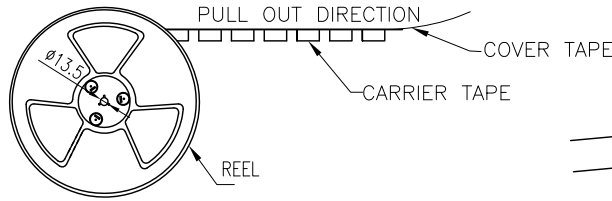
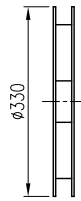
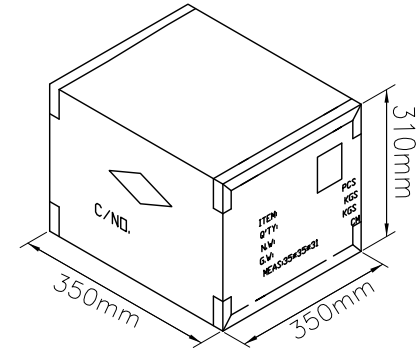
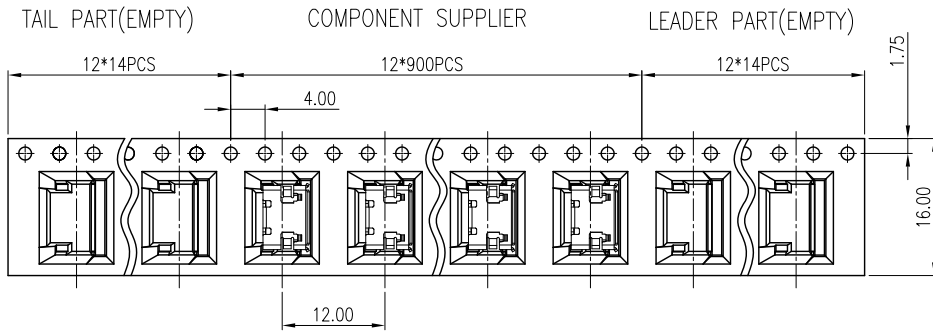

PACKAGING BY T&R	9.1	3.6	900	14	12600	GMCB053X1123H1HR
	G/W KG	N/W KG	PCS/REEL	REELS/BOX	QUANTITY (PCS)	PART NUMBER

TOLERANCE		APPROVALS		DATE		TITLE		Amphenol®					
X.		DRAWN	Debby Hung		11/27/2017	MICRO USB, B TYPE 5 POS. RECEPTACLE, R/A SMT SHELL DIP 2.95mm		Amphenol Corporation Amphenol Taiwan Corporation					
X.X	±0.30	CHECKED	Sandy Wu		11/27/2017								
X.XX	±0.20	APPROVED	Roger Tsai		11/27/2017								
X.XXX	±0.10	UNLESS OTHERWISE SPECIFIED		DWG TYPE	CUST DWG	PROJECT CODE	OTHER	UNIT	mm	SIZE	A3	PART No.	GMCB053X1123H1HR
				SCALE	NA	SHEET	2 OF 2	DWG No.	GMCB053X1123H1HR	REV.	A		