



MICROCHIP

MCP1632
Single-Cell Li-Ion
Battery Charger Demo Board
User's Guide

Note the following details of the code protection feature on Microchip devices:

- Microchip products meet the specification contained in their particular Microchip Data Sheet.
- Microchip believes that its family of products is one of the most secure families of its kind on the market today, when used in the intended manner and under normal conditions.
- There are dishonest and possibly illegal methods used to breach the code protection feature. All of these methods, to our knowledge, require using the Microchip products in a manner outside the operating specifications contained in Microchip's Data Sheets. Most likely, the person doing so is engaged in theft of intellectual property.
- Microchip is willing to work with the customer who is concerned about the integrity of their code.
- Neither Microchip nor any other semiconductor manufacturer can guarantee the security of their code. Code protection does not mean that we are guaranteeing the product as "unbreakable."

Code protection is constantly evolving. We at Microchip are committed to continuously improving the code protection features of our products. Attempts to break Microchip's code protection feature may be a violation of the Digital Millennium Copyright Act. If such acts allow unauthorized access to your software or other copyrighted work, you may have a right to sue for relief under that Act.

Information contained in this publication regarding device applications and the like is provided only for your convenience and may be superseded by updates. It is your responsibility to ensure that your application meets with your specifications. MICROCHIP MAKES NO REPRESENTATIONS OR WARRANTIES OF ANY KIND WHETHER EXPRESS OR IMPLIED, WRITTEN OR ORAL, STATUTORY OR OTHERWISE, RELATED TO THE INFORMATION, INCLUDING BUT NOT LIMITED TO ITS CONDITION, QUALITY, PERFORMANCE, MERCHANTABILITY OR FITNESS FOR PURPOSE. Microchip disclaims all liability arising from this information and its use. Use of Microchip devices in life support and/or safety applications is entirely at the buyer's risk, and the buyer agrees to defend, indemnify and hold harmless Microchip from any and all damages, claims, suits, or expenses resulting from such use. No licenses are conveyed, implicitly or otherwise, under any Microchip intellectual property rights.

Trademarks

The Microchip name and logo, the Microchip logo, dsPIC, FlashFlex, flexPWR, JukeBlox, KEELOQ, KEELOQ logo, Kleer, LANCheck, MediaLB, MOST, MOST logo, MPLAB, OptoLyzer, PIC, PICSTART, PIC³² logo, RightTouch, SpyNIC, SST, SST Logo, SuperFlash and UNI/O are registered trademarks of Microchip Technology Incorporated in the U.S.A. and other countries.

The Embedded Control Solutions Company and mTouch are registered trademarks of Microchip Technology Incorporated in the U.S.A.

Analog-for-the-Digital Age, BodyCom, chipKIT, chipKIT logo, CodeGuard, dsPICDEM, dsPICDEM.net, ECAN, In-Circuit Serial Programming, ICSP, Inter-Chip Connectivity, KleerNet, KleerNet logo, MiWi, MPASM, MPF, MPLAB Certified logo, MPLIB, MPLINK, MultiTRAK, NetDetach, Omniscient Code Generation, PICDEM, PICDEM.net, PICkit, PICtail, RightTouch logo, REAL ICE, SQI, Serial Quad I/O, Total Endurance, TSHARC, USBCheck, VariSense, ViewSpan, WiperLock, Wireless DNA, and ZENA are trademarks of Microchip Technology Incorporated in the U.S.A. and other countries.

SQTP is a service mark of Microchip Technology Incorporated in the U.S.A.

Silicon Storage Technology is a registered trademark of Microchip Technology Inc. in other countries.

GestIC is a registered trademarks of Microchip Technology Germany II GmbH & Co. KG, a subsidiary of Microchip Technology Inc., in other countries.

All other trademarks mentioned herein are property of their respective companies.

© 2014, Microchip Technology Incorporated, Printed in the U.S.A., All Rights Reserved.

ISBN: 978-1-63276-756-1

**QUALITY MANAGEMENT SYSTEM
CERTIFIED BY DNV
= ISO/TS 16949 =**

Microchip received ISO/TS-16949:2009 certification for its worldwide headquarters, design and wafer fabrication facilities in Chandler and Tempe, Arizona; Gresham, Oregon and design centers in California and India. The Company's quality system processes and procedures are for its PIC[®] MCUs and dsPIC[®] DSCs, KEELOQ[®] code hopping devices, Serial EEPROMs, microperipherals, nonvolatile memory and analog products. In addition, Microchip's quality system for the design and manufacture of development systems is ISO 9001:2000 certified.

Object of Declaration: MCP1632 Single-Cell Li-Ion Battery Charger Demo Board

EU Declaration of Conformity

Manufacturer: Microchip Technology Inc.
2355 W. Chandler Blvd.
Chandler, Arizona, 85224-6199
USA

This declaration of conformity is issued by the manufacturer.

The development/evaluation tool is designed to be used for research and development in a laboratory environment. This development/evaluation tool is not a Finished Appliance, nor is it intended for incorporation into Finished Appliances that are made commercially available as single functional units to end users under EU EMC Directive 2004/108/EC and as supported by the European Commission's Guide for the EMC Directive 2004/108/EC (8th February 2010).

This development/evaluation tool complies with EU RoHS2 Directive 2011/65/EU.

This development/evaluation tool, when incorporating wireless and radio-telecom functionality, is in compliance with the essential requirement and other relevant provisions of the R&TTE Directive 1999/5/EC and the FCC rules as stated in the declaration of conformity provided in the module datasheet and the module product page available at www.microchip.com.

For information regarding the exclusive, limited warranties applicable to Microchip products, please see Microchip's standard terms and conditions of sale, which are printed on our sales documentation and available at www.microchip.com.

Signed for and on behalf of Microchip Technology Inc. at Chandler, Arizona, USA

Derek Carlson
VP Development Tools

12-Sep-14
Date



MCP1632 SINGLE-CELL LI-ION BATTERY CHARGER DEMO BOARD USER'S GUIDE

Table of Contents

Preface	5
Introduction.....	5
Document Layout	5
Conventions Used in this Guide	6
Recommended Reading.....	7
The Microchip Web Site	7
Customer Support	7
Revision History	7
Chapter 1. Product Overview	
1.1 Introduction	9
1.2 Board Features	9
1.3 Device Summary	9
1.4 Technical Specifications	10
1.5 Functional Description	10
1.6 What Does the MCP1632 Single-Cell Li-Ion Battery Charger Demo Board Include?	11
Chapter 2. Installation and Operation	
2.1 Getting Started	13
2.1.1 Additional Components Required for Operation	13
2.2 Setup Procedure	13
2.2.1 Demo Board Output Current Configuration	13
2.2.2 Connecting the Single-Cell Battery	14
2.2.3 Powering the Board	14
2.2.4 Using the Reference Board	14
2.3 Evaluating the Application	15
2.4 Firmware description	15
2.4.1 Main Loop Description	16
2.4.2 State Machine Description	17
Appendix A. Schematic and Layouts	
A.1 Introduction	21
A.2 Board – Schematic	22
A.3 Board – Top Silk	23
A.4 Board – Top Copper and Silk	24
A.5 Board – Top Copper	25
A.6 Board – Bottom Copper	26
A.7 Board – Bottom Copper and Silk	27
Appendix B. Bill of Materials (BOM)	
Worldwide Sales and Service	32



MCP1632 SINGLE-CELL LI-ION BATTERY CHARGER DEMO BOARD USER'S GUIDE

Preface

NOTICE TO CUSTOMERS

All documentation becomes dated, and this manual is no exception. Microchip tools and documentation are constantly evolving to meet customer needs, so some actual dialogs and/or tool descriptions may differ from those in this document. Please refer to our web site (www.microchip.com) to obtain the latest documentation available.

Documents are identified with a “DS” number. This number is located on the bottom of each page, in front of the page number. The numbering convention for the DS number is “DSXXXXXXXXA”, where “XXXXXXXX” is the document number and “A” is the revision level of the document.

For the most up-to-date information on development tools, see the MPLAB® IDE online help. Select the Help menu, and then Topics to open a list of available online help files.

INTRODUCTION

This chapter contains general information that will be useful to know before using the MCP1632 Single-Cell Li-Ion Battery Charger Demo Board. Items discussed in this chapter include:

- Document Layout
- Conventions Used in this Guide
- Recommended Reading
- Recommended Reading
- The Microchip Web Site
- Customer Support
- Customer Support
- Revision History

DOCUMENT LAYOUT

This document describes how to use the MCP1632 Single-Cell Li-Ion Battery Charger Demo Board as a development tool to emulate and debug firmware on a target board, as well as how to program devices. The document is organized as follows:

- **Chapter 1. “Product Overview”** – Important information about the MCP1632 Single-Cell Li-Ion Battery Charger Demo Board.
- **Chapter 2. “Installation and Operation”** – Includes instructions on how to get started with this user’s guide and a description of the user’s guide.
- **Appendix A. “Schematic and Layouts”** – Shows the schematic and layout diagrams for the MCP1632 Single-Cell Li-Ion Battery Charger Demo Board.
- **Appendix B. “Bill of Materials (BOM)”** – Lists the parts used to build the MCP1632 Single-Cell Li-Ion Battery Charger Demo Board.

CONVENTIONS USED IN THIS GUIDE

This manual uses the following documentation conventions:

DOCUMENTATION CONVENTIONS

Description	Represents	Examples
Arial font:		
Italic characters	Referenced books	<i>MPLAB[®] IDE User's Guide</i>
	Emphasized text	...is the <i>only</i> compiler...
Initial caps	A window	the Output window
	A dialog	the Settings dialog
	A menu selection	select Enable Programmer
Quotes	A field name in a window or dialog	"Save project before build"
Underlined, italic text with right angle bracket	A menu path	<u><i>File>Save</i></u>
Bold characters	A dialog button	Click OK
	A tab	Click the Power tab
N'Rnnnn	A number in verilog format, where N is the total number of digits, R is the radix and n is a digit.	4'b0010, 2'hF1
Text in angle brackets < >	A key on the keyboard	Press <Enter>, <F1>
Courier New font:		
Plain Courier New	Sample source code	#define START
	Filenames	autoexec.bat
	File paths	c:\mcc18\h
	Keywords	_asm, _endasm, static
	Command-line options	-Opa+, -Opa-
	Bit values	0, 1
	Constants	0xFF, 'A'
Italic Courier New	A variable argument	<i>file.o</i> , where <i>file</i> can be any valid filename
Square brackets []	Optional arguments	mcc18 [options] <i>file</i> [options]
Curly brackets and pipe character: { }	Choice of mutually exclusive arguments; an OR selection	errorlevel {0 1}
Ellipses...	Replaces repeated text	var_name [, var_name...]
	Represents code supplied by user	void main (void) { ... }

RECOMMENDED READING

This user's guide describes how to use the MCP1632 Single-Cell Li-Ion Battery Charger Demo Board. Other useful documents are listed below. The following Microchip documents are available and recommended as supplemental reference resources.

- **MCP1632 Data Sheet – “High-Speed, Low-Side PWM Controller” (DS20005254)**

THE MICROCHIP WEB SITE

Microchip provides online support via our web site at www.microchip.com. This web site is used as a means to make files and information easily available to customers. Accessible by using your favorite Internet browser, the web site contains the following information:

- **Product Support** – Data sheets and errata, application notes and sample programs, design resources, user's guides and hardware support documents, latest software releases and archived software
- **General Technical Support** – Frequently Asked Questions (FAQs), technical support requests, online discussion groups, Microchip consultant program member listing
- **Business of Microchip** – Product selector and ordering guides, latest Microchip press releases, listing of seminars and events, listings of Microchip sales offices, distributors and factory representatives

CUSTOMER SUPPORT

Users of Microchip products can receive assistance through several channels:

- Distributor or Representative
- Local Sales Office
- Field Application Engineer (FAE)
- Technical Support

Customers should contact their distributor, representative or field application engineer (FAE) for support. Local sales offices are also available to help customers. A listing of sales offices and locations is included in the back of this document.

Technical support is available through the web site at:

<http://www.microchip.com/support>.

REVISION HISTORY

Revision A (November 2014)

- Initial release of this document.

MCP1632 Single-Cell Li-Ion Battery Charger Demo Board User's Guide

NOTES:

Chapter 1. Product Overview

1.1 INTRODUCTION

The MCP1632 Single-Cell Li-Ion Battery Charger Demo Board is a step-up/step-down, switch-mode, DC/DC converter used for battery charging applications. The demo board provides a 4.2V constant voltage source. Other output voltages can be obtained with minor modifications to the board's Bill of Materials (BOM).

The MCP1632 Single-Cell Li-Ion Battery Charger Demo Board is an intelligent battery charging system for a single-cell Lithium-Ion battery. MCP1632 Single-Cell Li-Ion Battery Charger Demo Board utilizes Microchip's MCP1632 high-speed Pulse-Width Modulator (PWM). The 8-pin MCP1632 device contains all the analog components necessary for a peak current mode control loop including an error amplifier, PWM comparator and a high-current driver output pin.

An 8-pin PIC12F1822 microcontroller is used to implement the charging algorithm. In addition, the PIC12F1822 firmware supervises the battery voltage and current.

1.2 BOARD FEATURES

The MCP1632 Single-Cell Li-Ion Battery Charger Demo Board has the following features:

- Compact size, highly efficient battery charger
- Can operate in Buck (step-down) or Boost (step-up) mode
- Maximum output current: 1500 mA; can be adjusted via firmware
- Chemistry-optimized charging algorithm
- Maximum output power: 7W
- Factory-programmed source code provided
- Additional application functions can be implemented in the firmware

1.3 DEVICE SUMMARY

The MCP1632 Single-Cell Li-Ion Battery Charger Demo Board uses the following primary devices on the board:

- MCP1632 high-speed current mode PWM controller. – When used in conjunction with a microcontroller, the MCP1632 will control the power system duty cycle to provide output current and/or voltage regulation.
- PIC12F1822 microcontroller (8-bit MCU) – Used to implement the charging algorithm and to provide additional software functions like protections.
- MCP1703 low dropout regulator (LDO) – Used to supply regulated voltage (+5V) to the PIC12F1822 microcontroller and the MCP1632 PWM controller
- MCP6021 operational amplifier – Used for the current sensing circuit.

1.4 TECHNICAL SPECIFICATIONS

- Input voltage: +4.5V to +12V
- Load disconnect protection software configurable
- Typical output current: 1000 mA
- Maximum output current: 1500 mA (with firmware adjustments)
- Typical output power: 4.2W (maximum 7W at +25°C degree ambient temperature)
- Fully protected against Short-Circuit and No Load condition
- Figure 1-1 shows a simplified block diagram of the application

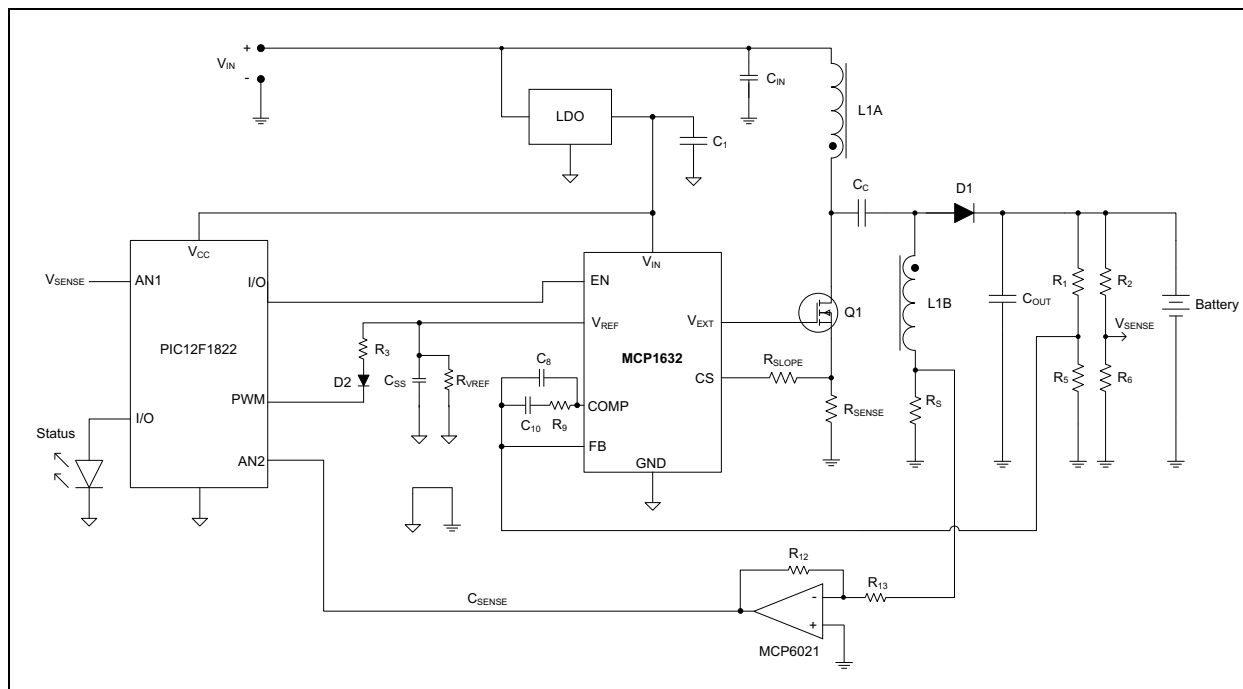

FIGURE 1-1: MCP1632 Block Diagram.

1.5 FUNCTIONAL DESCRIPTION

MCP1632 provides all the analog functions necessary to implement a stand-alone switch-mode power converter. When combined with an external microcontroller, the MCP1632 can be used to implement different intelligent converters like those necessary for battery chargers.

The power train of this application uses the Single-Ended Primary Inductor Converter (SEPIC) topology. This topology offers buck-boost functionality and also has non-pulsating input current.

The converter provides constant voltage with limited current at the output, necessary for certain battery charging applications (ex. Li-Ion-based batteries).

The output voltage is measured with a voltage divider resistor pair (R_1 , R_5). This voltage must be precisely 4.2V, required by the battery chemistry.

The average current in the L1B inductor, which is also the output current of the converter, is sensed using a 0.1Ω shunt resistor (R_S). As the voltage across the shunt resistor is negative, a -10x amplifier (U_3) is used for battery charging current sensing. The conversion gain of this circuit is 1V/A.

The PWM output available from the PIC12F1822 microcontroller is used to control the reference voltage of the MCP1632 using the circuit created with D2 and R3 components.

Maximum output current is set by the PIC12F1822 microcontroller.

1.6 WHAT DOES THE MCP1632 SINGLE-CELL LI-ION BATTERY CHARGER DEMO BOARD INCLUDE?

The MCP1632 Single-Cell Li-Ion Battery Charger Demo Board includes:

- MCP1632 Single-Cell Li-Ion Battery Charger Demo Board (ARD00558)
- Information Sheet

MCP1632 Single Cell Li-Ion Battery Charger Demo Board User's Guide

NOTES:

Chapter 2. Installation and Operation

2.1 GETTING STARTED

The MCP1632 Single-Cell Li-Ion Battery Charger Demo Board is fully assembled and tested. The board requires the use of an external input voltage source (+4.5V to +12V).

2.1.1 Additional Components Required for Operation

- A DC Power Supply. A bench supply that can produce between 4.5V and 12V, 2A is recommended to operate the board at the full rated power. A USB connector can also be used. In this case, make sure that the input current does not exceed the USB connector requirements. Note that there is no USB device enumeration mechanism on this board.
- An oscilloscope and/or multi-meter to observe waveforms and measure electrical parameters (optional).

2.2 SETUP PROCEDURE

To operate the demonstration board, you need to complete the following steps:

1. Connect a power supply to the input connector J1 (observe the polarity).
2. Attach a single-cell battery to the output connector J2 (observe the polarity).
3. Press the Start/Stop Button to start the battery charging and again to stop it.

Detailed instructions are provided below for each step.

WARNING

Please observe the polarity for all steps to avoid board damage.
--

2.2.1 Demo Board Output Current Configuration

The board is configured to deliver 1000 mA to a single-cell battery. Maximum output voltage is set to approximately 4.2V.

2.2.2 Connecting the Single-Cell Battery

A single-cell battery can be used to evaluate the board. In this case, the power delivered to the load will be about 4.2W.

The board can charge a single-cell battery with 1000 mA as the output current. Maximum output voltage is set to 4.2V (Li-Ion specific) for the default software/hardware configuration. The output voltage can be modified with minor software/hardware modifications.

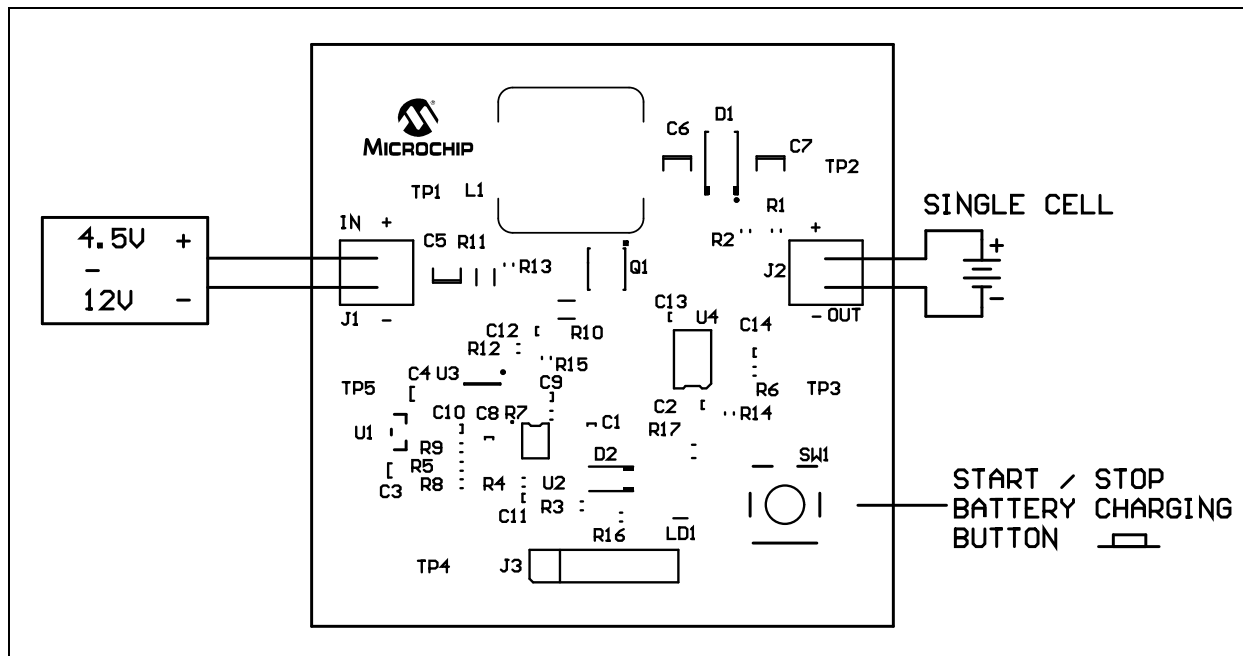

FIGURE 2-1: Power Supply and Load Connection Diagram.

2.2.3 Powering the Board

Connect a power supply to J1 to power-up the MCP1632 Single-Cell Li-Ion Battery Charger Demo Board. Ensure that the power supply has the (+) terminal connected to J2 terminal block at pin 1 (up) and (-) terminal connected to pin 2 (down). The input voltage source should be limited to the 4.5V to 12V range. Ensure that the chosen power supply can provide enough current at the selected voltage to properly charge the single-cell battery.

For 12V input voltage the current drain will be around 650 mA at full load (7W).

WARNING

This board does not have a Thermal Shut-Down function implemented. Please ensure that the board load is properly cooled.

2.2.4 Using the Reference Board

The button is used to start or stop the battery charging.

Board is protected for the No-Load Condition. Typical value is +4.2 V_{DC} for the output voltage.

Note: It is not recommended to operate the board without a proper load connected to output. Maximum power at the output must be limited to 7W at ambient temperature

2.3 EVALUATING THE APPLICATION

The best way to evaluate the MCP1632 Single-Cell Li-Ion Battery Charger Demo Board is to examine the circuit and measure voltages and currents with a Digital Voltage Meter (DVM) and probe the board with an oscilloscope.

Additional tools are necessary to evaluate some technical parameters of the board (temperature of power components, ability to withstand surge voltage pulse on input, EMI).

The firmware program in the PIC12F1822 can also be edited to modify the operation of the application.

2.4 FIRMWARE DESCRIPTION

The PIC12F1822 comes pre-programmed with firmware to operate the system as described above. The firmware structure is shown in Figure 2-2.

The main loop controls all the voltage and current regulating functions. The battery charging state machine is only called every second and makes decisions based only on the output voltage and current values. It sets the voltage and current limit, depending on the charging state.

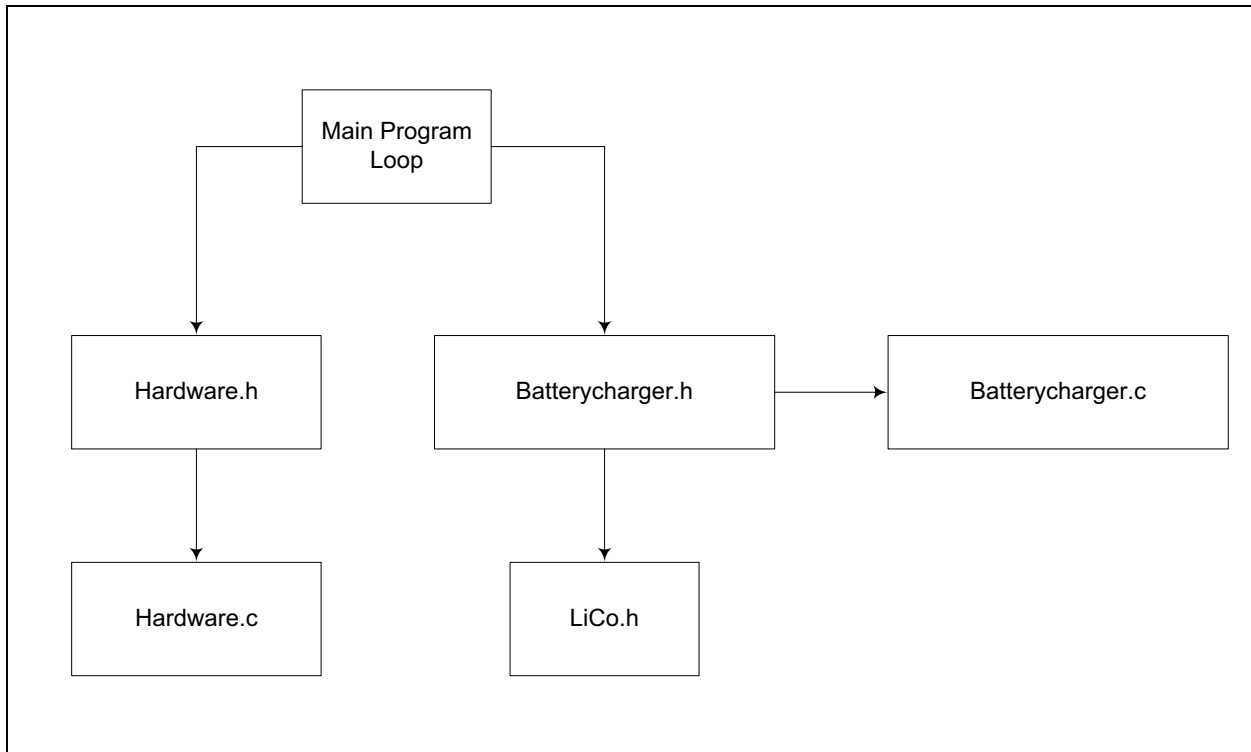

FIGURE 2-2: Library File Structure.

2.4.1 Main Loop Description

The charger state machine is hardware independent, so all the output regulation is done in the main loop.

Besides calling the state machine every second, different parameters and macros are required for the state machine code. All values are 12 bits (4 x 10-bit ADC readings).

V_{SENSE} and I_{SENSE} contain updated values of the output voltage and current. They can be defined as macros or return functions:

- `#define VSENSE VOUT`
- `#define ISENSE IOUT`

`Set_Voltage(x)` and `Set_Current(x)` set the converter maximum output voltage and current. They can be defined as macros or functions:

- `#define Set_Voltage(x) { vref = x; }`
- `#define Set_Current(x) { iref = x; }`

`Set_Led_Blink(x)` sets the LED state and blink rate to show the current battery charging state.

`Constant_Voltage` should show whether the converter is regulating the output voltage or not. This is important for the state machine, because the minimum current and flat current charge termination should only be initiated in Constant Voltage mode.

- `#define Constant_Voltage (!cmode)`

`I_Bat_Detect` is a minimum current reading that shows a missing battery/load. The value depends on the current shunt amplifier offset and amplification. It is useful for detecting that the battery has been removed during charge, since there is no OCV (Open Circuit Voltage) measurement.

- `#define I_Bat_Detect 16`

2.4.2 State Machine Description

There are five states, as shown in Figure 2-3 and explained in Table 2-1.

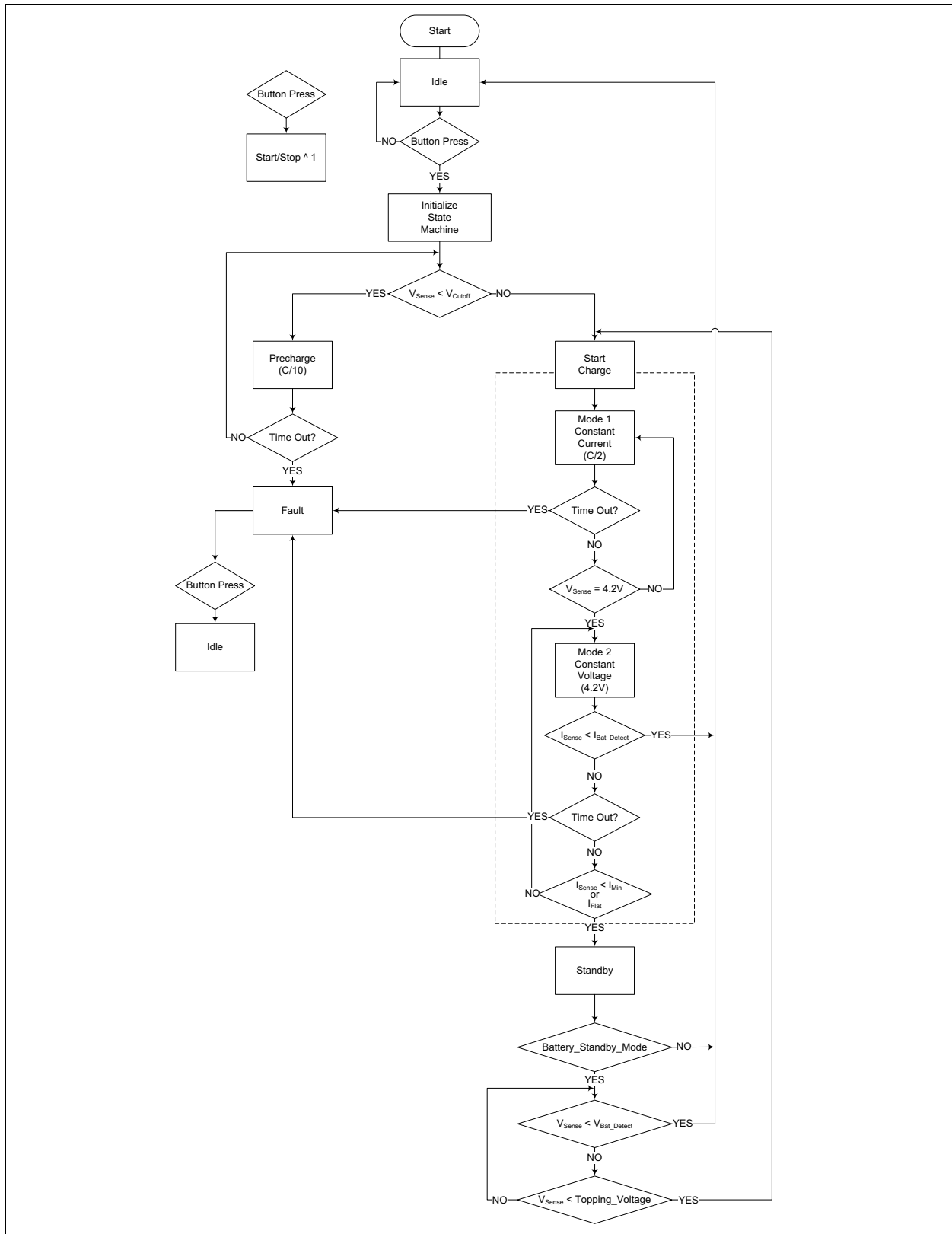

FIGURE 2-3: The Charger State Machine.

TABLE 2-1: CHARGING STATES

State	Description
Precharge	Charges battery with a low current (usually C/10) until the battery voltage exceeds the defined cutoff voltage.
Charge	The Charge state has two phases: constant current mode and constant voltage mode. The Charge cycle starts in constant current mode, in which the battery is charged with a constant current (usually C/2) until the battery voltage equals +4.2 V _{DC} . After that, it enters the constant voltage mode, keeping a constant voltage at the output (+4.2 V _{DC}). When the current is under the minimum threshold or it does not decrease for a certain time (flat current), the state machine switches to Done state. If the battery is removed before the charging is complete (battery current is under the battery detection current), then the state machine switches to Idle state. If a time out occurs before any of these conditions are triggered, then the state machine will switch to Fault state.
Done	When the state machine reaches this state, it means that the battery is fully charged and can be removed. The converter is stopped, but, if a special Standby_mode is enabled, then this state will monitor the OCV (Open Circuit Voltage) of the battery and jump back to the Charge state, when it drops too much. If the Standby_mode is not enabled, then it switches to Idle state.
Idle	In this state, the converter is stopped and the whole system waits for user input. A button press reinitializes the state machine, and the charging process starts from the beginning.
Fault	Stops the converter and waits for user input. A button press changes the state to Idle.

An LED is used to signal the charging state. The on/off states and blinking rates are defined in `Hardware.h`.

TABLE 2-2: LED STATES

LED State	Description
LED Off	Idle state
LED blinking 0.5 Hz	Precharge and Charge states
LED On	Done state
LED blinking 2 Hz	Fault state

2.4.2.1 CHARGER VARIABLES AND FUNCTIONS

Battery_state – Holds the current charging state of the battery charger. This variable is available to the main program loop.

```
enum charge_states { IDLE = 0, FAULT = 1, DONE = 2, PRECHARGE = 3, CHARGE = 4, FLOAT = 5 };
```

State_counter – Used as a time-out counter for Precharge and Charge states.

I_{MIN} – The minimum current value recorded during the constant voltage phase of the Charge state. When the value of this variable falls below the minimum current threshold (calculated as a fraction of the battery capacity), the charge is complete.

I_{MIN_DB} – The minimum current debouncing counter. When the value of I_{SENSE} is smaller than I_{MIN} for I_{MIN_UPDATE} times in a row, I_{MIN} is updated with the value of I_{SENSE}.

I_{FLAT_DB} – The flat current debouncing counter. This counter is reset every time I_{MIN} is updated. When it reaches zero, it triggers an End of Charge condition.

The charger library has two functions:

- `Init_State_Machine()` initializes the state machine debouncing and time-out counters, sets the charging voltage and current limits and starts the converter. This function should be called when starting to charge from Idle.
- `Battery_State_Machine()` contains the code for each of the charge/battery state machines and will handle state transitions based on the measured current and voltage values. This function expects to be called every second, otherwise the time-out counters measure a different interval.

2.4.2.2 THE BATTERY CHEMISTRY DEFINITION FILES

LiCo.h contains example definitions for charging this chemistry.

It supports all Li-Ion chemistries that have a charging voltage of 4.2V. For Li-Fe cells the charging voltage needs to be changed to 3.6V.

The values in the definition files depend on the charger hardware implementation and the number of ADC samples taken on each measurement. In this case, we have a 10-bit ADC with a 5V reference, and four samples are taken for every measurement. The output current shunt is 0.1Ω, amplified 10 times. The output voltage divider is 2.44.

EQUATION 2-1: VOLTAGE CALCULATION EXAMPLE FOR 4.2V

$$\text{Voltage Counts} = \frac{\text{ADC maximum} \times \text{Voltage}}{\text{Output Divider} \times \text{ADC Reference}}$$

$$\text{Counts} = \frac{4096 \times 4.2\text{V}}{2.44 \times 2.048\text{V}} = 3443$$

EQUATION 2-2: CURRENT CALCULATION EXAMPLE FOR 1000 MA

$$\text{Current Counts} = \frac{\text{ADC maximum} \times \text{Current} \times \text{Shunt Value} \times \text{Amplification}}{\text{ADC Reference}}$$

$$\text{Counts} = \frac{4096 \times 1\text{A} \times 0.1\Omega \times 10}{2.048\text{V}} = 2000$$

MCP1632 Single-Cell Li-Ion Battery Charger Demo Board User's Guide

NOTES:



MCP1632 SINGLE-CELL LI-ION BATTERY CHARGER DEMO BOARD USER'S GUIDE

Appendix A. Schematic and Layouts

A.1 INTRODUCTION

This appendix contains the following schematics and layouts for the MCP1632 Single-Cell Li-Ion Battery Charger Demo Board:

- Board – Schematic
- Board – Top Silk
- Board – Top Copper and Silk
- Board – Top Copper
- Board – Bottom Copper
- Board – Bottom Copper and Silk

A.2 BOARD – SCHEMATIC

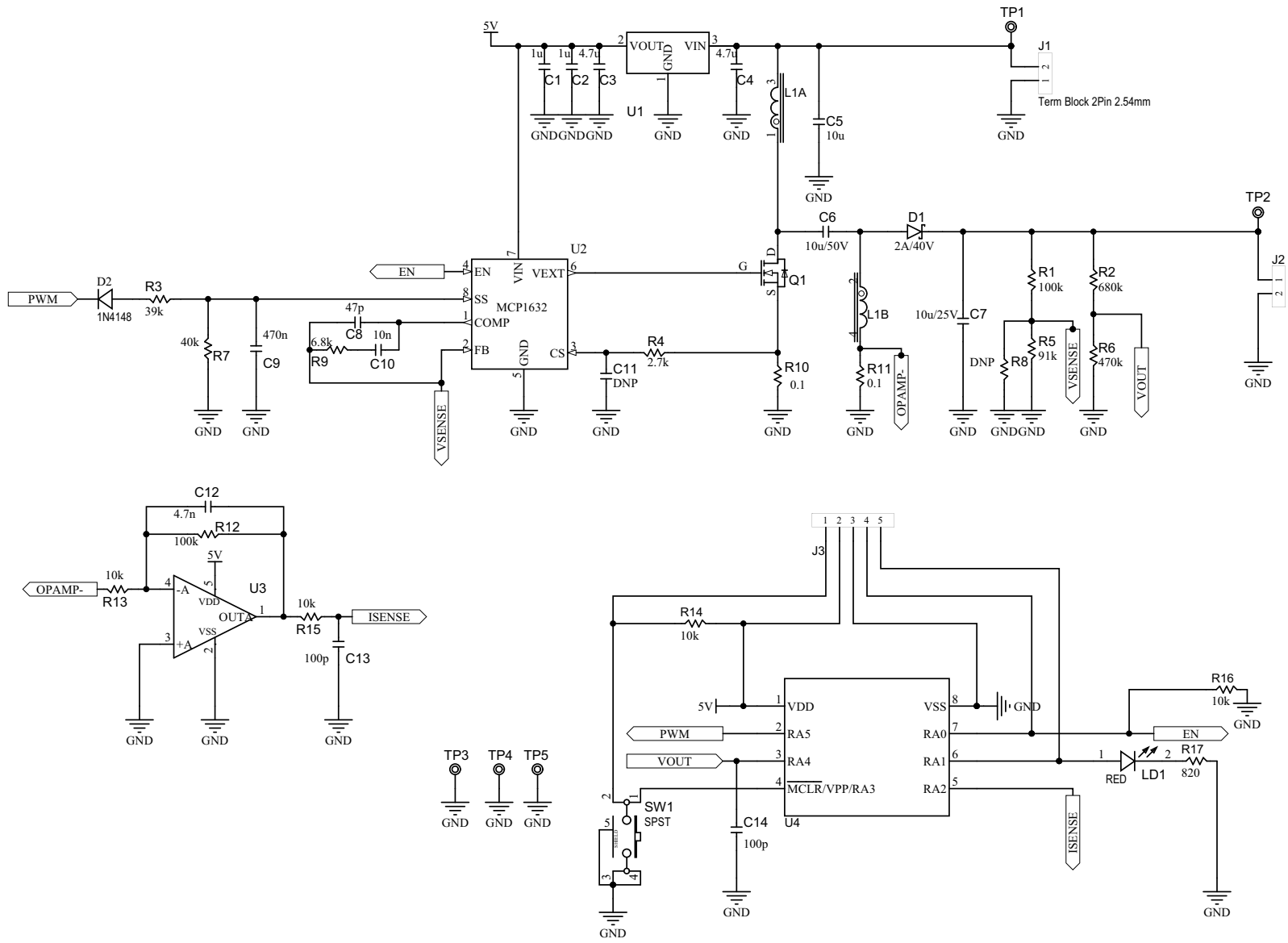

A.3 BOARD – TOP SILK

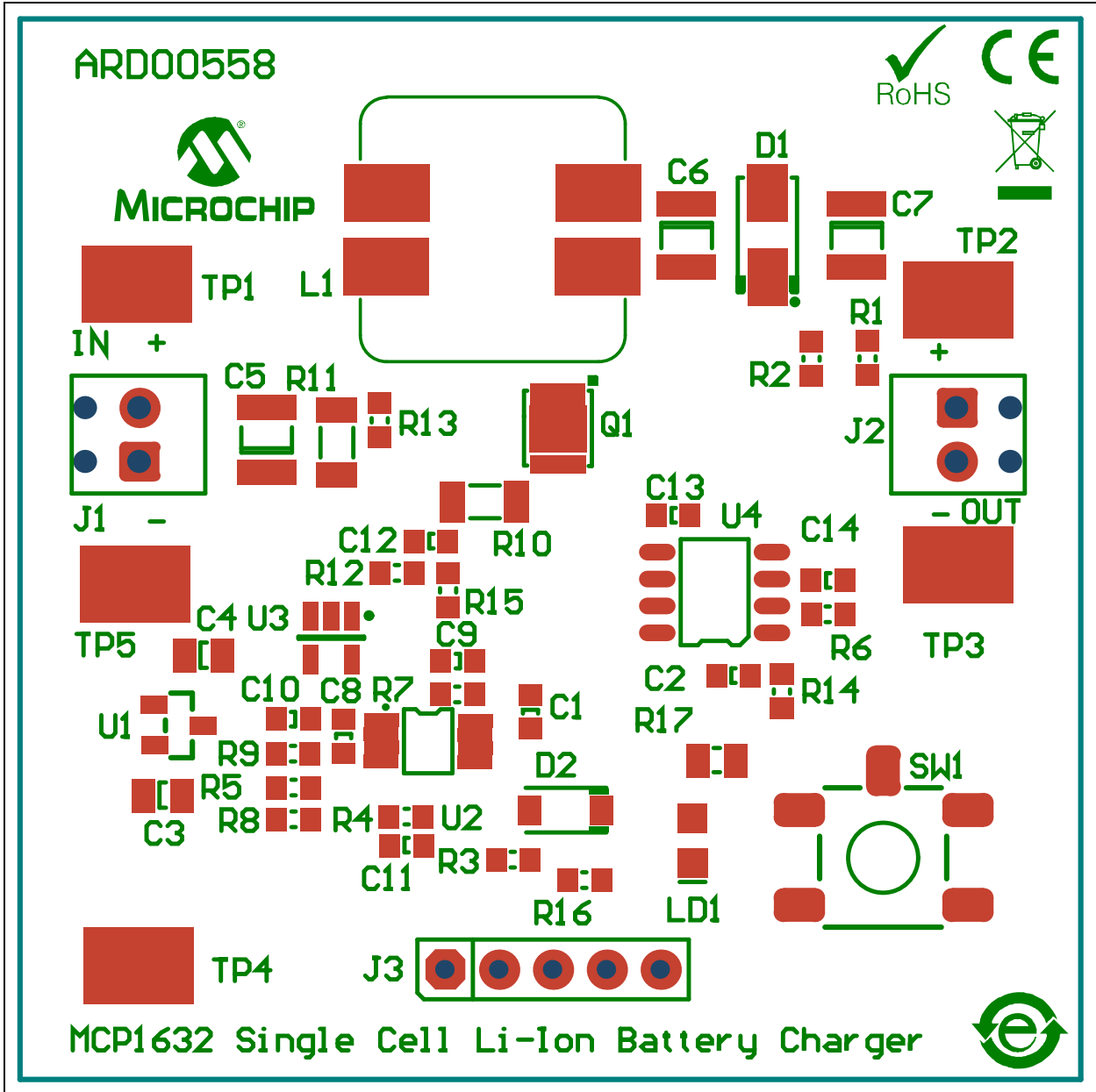

A.4 BOARD – TOP COPPER AND SILK

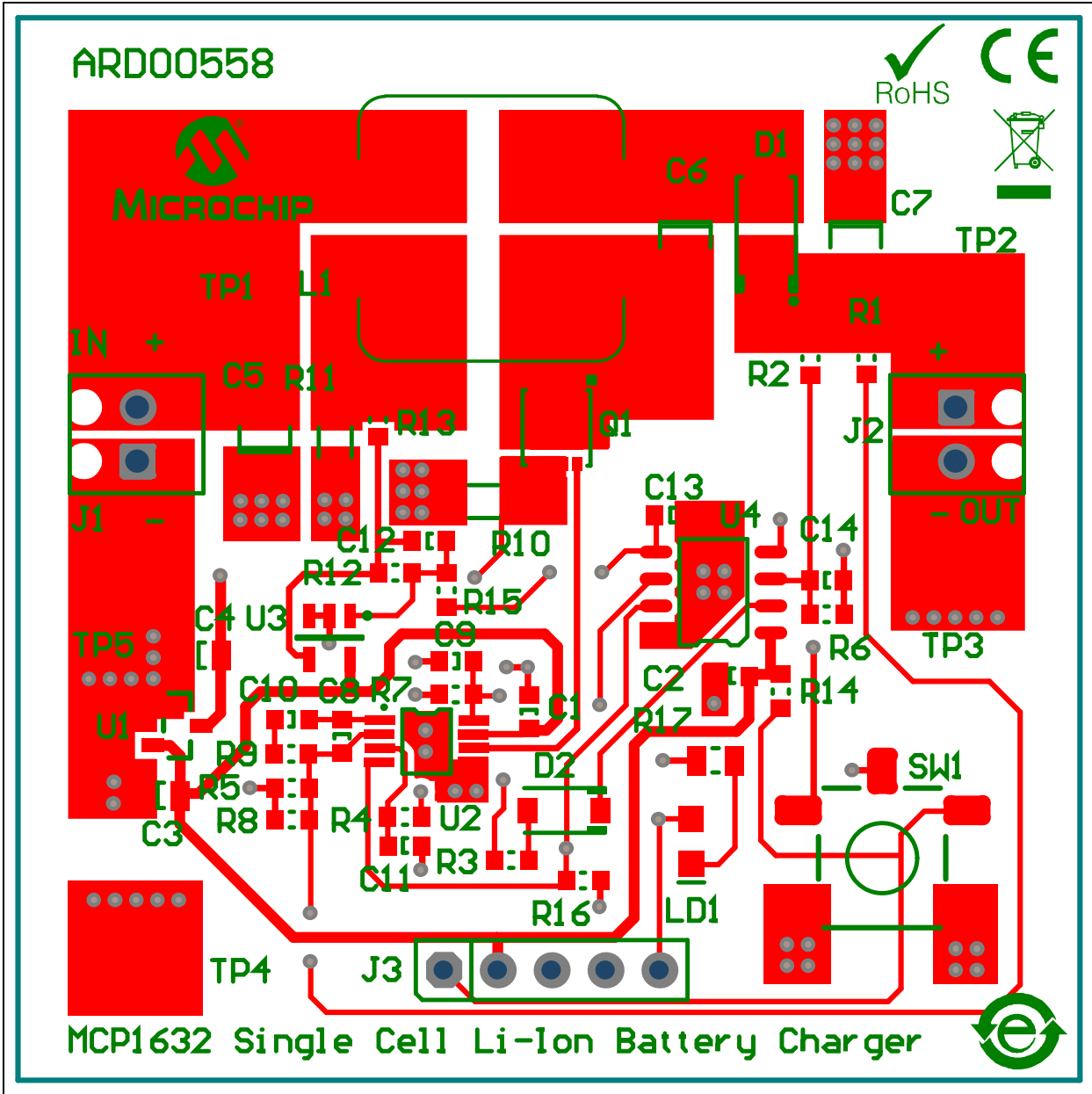

A.5 BOARD – TOP COPPER

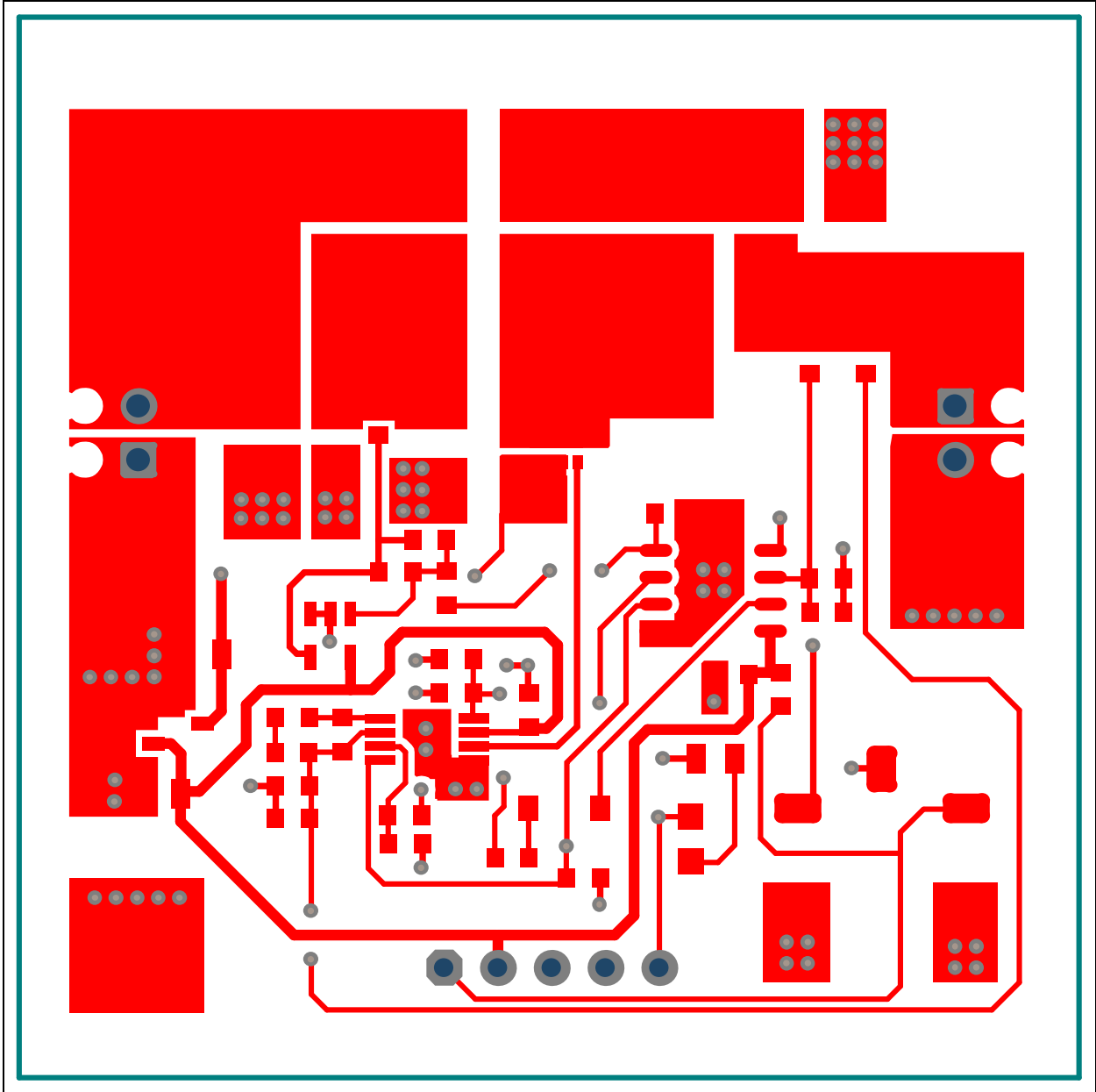

A.6 BOARD – BOTTOM COPPER

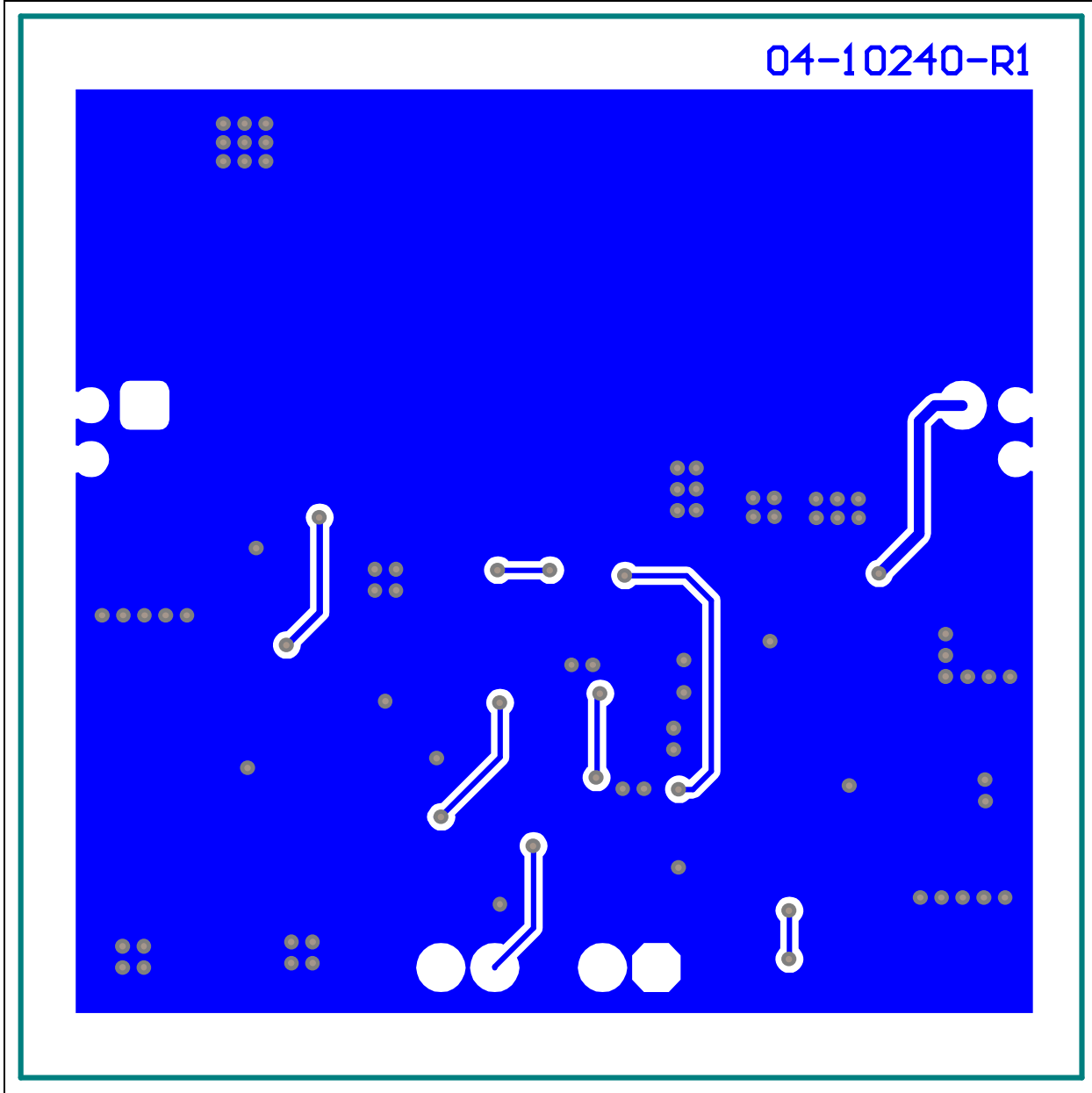

A.7 BOARD – BOTTOM COPPER AND SILK

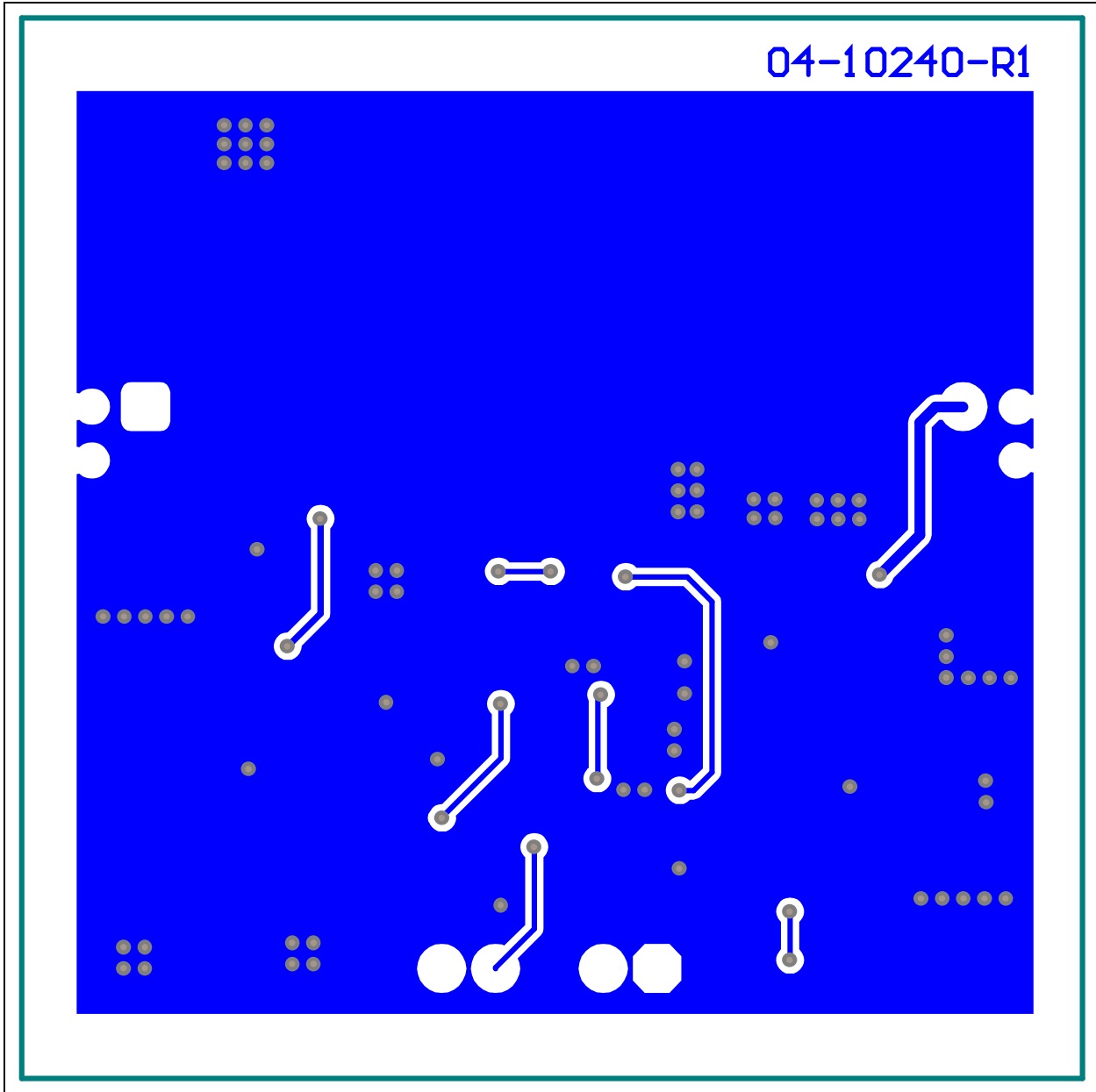

MCP1632 Single-Cell Li-Ion Battery Charger Demo Board User's Guide

NOTES:



MCP1632 SINGLE-CELL LI-ION BATTERY CHARGER DEMO BOARD USER'S GUIDE

Appendix B. Bill of Materials (BOM)

TABLE B-1: BILL OF MATERIALS

Quantity	Designator	Description	Manufacturer	Manufacturer Part Number
2	C1, C2	Cap. ceramic 1 μ F 16V 10% X7R 0603	TDK Corporation	C1608X7R1C105K080AC
2	C3, C4	Cap. ceramic 4.7 μ F 10V 20% X7R 0805	TDK Corporation	C2012X7R1A475M125AC
3	C5, C6, C7	Cap. ceramic 10 μ F 16V 20% X7R 1210	TDK Corporation	C3225X7R1C106M200AB
1	C8	Cap. ceramic 47 pF 50V 5% NP0 0603	TDK Corporation	C1608C0G1H470J080AA
1	C9	Cap. ceramic 0.47 μ F 16V 10% X7R 0603	TDK Corporation	C1608X7R1C474K080AC
1	C10	Cap. ceramic 10000 pF 50V 10% X7R 0603	TDK Corporation	C1608X7R1H103K080AA
0	C11	DO NOT POPULATE	—	—
1	C12	Cap. ceramic 4700 pF 50V 10% X7R 0603	TDK Corporation	CGA3E2X7R1H472K080AA
2	C13, C14	Cap. ceramic 100 pF 50V 5% NP0 0603	TDK Corporation	C1608C0G1H101J080AA
1	D1	Diode Schottky 40V 2A DO214AC	Vishay Intertechnology, Inc.	SSA24-E3/61T
1	D2	Diode Rec. 1N4148 1.25V 150 mA 100V SOD-123	Micro Commercial Components	1N4148W-TP
2	J1, J2	Conn. terminal blk. 2.54 mm 2POS	PHOENIX CONTACT	1725656
1	J3	Conn. header 5POS vert. 0.100 GOLD	FCI	68002-205HLF
1	L1	Coupled inductor SEPIC/CIUK 4.7 μ H	Würth® Group	744878004
1	LD1	LED red orange clear 0603 SMD	Lite-On® Technology Corporation	LTST-C190EKT
1	PCB	MCP1632 Single-Cell Li-Ion Battery Charger Demo Board – Printed Circuit Board	Microchip Technology Inc.	104-10240
1	Q1	MOSFET N-CH 25V 8PDFN	Microchip Technology Inc.	MCP87130T-U/MF
2	R1, R12	Res. 100 k Ω 1/10W 1% 0603	Stackpole Electronics, Inc.	RMCF0603FT100K
1	R2	Res. 680 k Ω 1/10W 1% 0603	Stackpole Electronics, Inc.	RMCF0603FT680K
1	R3	Res. 39 k Ω 1/10W 1% 0603	Stackpole Electronics, Inc.	RMCF0603FT39K0

Note: The components listed in this Bill of Materials are representative of the PCB assembly. The released BOM used in manufacturing uses all RoHS-compliant components.

MCP1632 Single-Cell Li-Ion Battery Charger Demo Board User's Guide

TABLE B-1: BILL OF MATERIALS (CONTINUED)

Quantity	Designator	Description	Manufacturer	Manufacturer Part Number
1	R4	Res. 2.7 kΩ 1/10W 5% 0603	Stackpole Electronics, Inc.	RMCF0603JT2K70
1	R5	Res. 91 kΩ 1/10W 5% 0603	Stackpole Electronics, Inc.	RMCF0603JT91K0
1	R6	Res. 470 kΩ 1/10W 5% 0603	Stackpole Electronics, Inc.	RMCF0603JT470K
1	R7	Res. 40 kΩ 0.15W 0.1% 0603	Vishay Intertechnology, Inc.	PAT0603E4002BST1
0	R8	DO NOT POPULATE	—	—
1	R9	Res. 6.8 kΩ 1/10W 5% 0603	Stackpole Electronics, Inc.	RMCF0603JT6K80
4	R13, R14, R15, R16	Res. 10 kΩ 1/10W 5% 0603	Stackpole Electronics, Inc.	RMCF0603JT10K0
1	R17	Res. 820Ω 1/10W 5% 0603	Stackpole Electronics, Inc.	RMCF0603JT820R
2	R10, R11	Res. 0.1Ω 1/2W 1% 1206 SMD	Bourns®, Inc.	CRM1206-FX-R100ELF
1	SW1	Switch tact. SPST-NO 0.05A 24V	Omron Electronics – EMC Division	B3S-1100P
1	U1	MCHP Analog LDO 5V MCP1703T-5002E/MB SOT-89-3	Microchip Technology Inc.	MCP1703T-5002E/MB
1	U2	IC Reg. CTRLR BOOST CM PWM 8MSOP	Microchip Technology Inc.	MCP1632-BAE/MS
1	U3	MCHP Analog OPAMP 1-Ch 1 MHz MCP6001T-I/OT SOT-23-5	Microchip Technology Inc.	MCP6001T-I/OT
1	U4	IC MCU 8BIT 3.5KB FLASH 8SOIC	Microchip Technology Inc.	PIC12F1822-I/SN

Note: The components listed in this Bill of Materials are representative of the PCB assembly. The released BOM used in manufacturing uses all RoHS-compliant components.

NOTES:



MICROCHIP

Worldwide Sales and Service

AMERICAS

Corporate Office
2355 West Chandler Blvd.
Chandler, AZ 85224-6199
Tel: 480-792-7200
Fax: 480-792-7277
Technical Support:
<http://www.microchip.com/support>
Web Address:
www.microchip.com

Atlanta
Duluth, GA
Tel: 678-957-9614
Fax: 678-957-1455

Austin, TX
Tel: 512-257-3370

Boston
Westborough, MA
Tel: 774-760-0087
Fax: 774-760-0088

Chicago
Itasca, IL
Tel: 630-285-0071
Fax: 630-285-0075

Cleveland
Independence, OH
Tel: 216-447-0464
Fax: 216-447-0643

Dallas
Addison, TX
Tel: 972-818-7423
Fax: 972-818-2924

Detroit
Novi, MI
Tel: 248-848-4000

Houston, TX
Tel: 281-894-5983

Indianapolis
Noblesville, IN
Tel: 317-773-8323
Fax: 317-773-5453

Los Angeles
Mission Viejo, CA
Tel: 949-462-9523
Fax: 949-462-9608

New York, NY
Tel: 631-435-6000

San Jose, CA
Tel: 408-735-9110

Canada - Toronto
Tel: 905-673-0699
Fax: 905-673-6509

ASIA/PACIFIC

Asia Pacific Office
Suites 3707-14, 37th Floor
Tower 6, The Gateway
Harbour City, Kowloon
Hong Kong
Tel: 852-2943-5100
Fax: 852-2401-3431

Australia - Sydney
Tel: 61-2-9868-6733
Fax: 61-2-9868-6755

China - Beijing
Tel: 86-10-8569-7000
Fax: 86-10-8528-2104

China - Chengdu
Tel: 86-28-8665-5511
Fax: 86-28-8665-7889

China - Chongqing
Tel: 86-23-8980-9588
Fax: 86-23-8980-9500

China - Hangzhou
Tel: 86-571-8792-8115
Fax: 86-571-8792-8116

China - Hong Kong SAR
Tel: 852-2943-5100
Fax: 852-2401-3431

China - Nanjing
Tel: 86-25-8473-2460
Fax: 86-25-8473-2470

China - Qingdao
Tel: 86-532-8502-7355
Fax: 86-532-8502-7205

China - Shanghai
Tel: 86-21-5407-5533
Fax: 86-21-5407-5066

China - Shenyang
Tel: 86-24-2334-2829
Fax: 86-24-2334-2393

China - Shenzhen
Tel: 86-755-8864-2200
Fax: 86-755-8203-1760

China - Wuhan
Tel: 86-27-5980-5300
Fax: 86-27-5980-5118

China - Xian
Tel: 86-29-8833-7252
Fax: 86-29-8833-7256

China - Xiamen
Tel: 86-592-2388138
Fax: 86-592-2388130

China - Zhuhai
Tel: 86-756-3210040
Fax: 86-756-3210049

ASIA/PACIFIC

India - Bangalore
Tel: 91-80-3090-4444
Fax: 91-80-3090-4123

India - New Delhi
Tel: 91-11-4160-8631
Fax: 91-11-4160-8632

India - Pune
Tel: 91-20-3019-1500

Japan - Osaka
Tel: 81-6-6152-7160
Fax: 81-6-6152-9310

Japan - Tokyo
Tel: 81-3-6880-3770
Fax: 81-3-6880-3771

Korea - Daegu
Tel: 82-53-744-4301
Fax: 82-53-744-4302

Korea - Seoul
Tel: 82-2-554-7200
Fax: 82-2-558-5932 or
82-2-558-5934

Malaysia - Kuala Lumpur
Tel: 60-3-6201-9857
Fax: 60-3-6201-9859

Malaysia - Penang
Tel: 60-4-227-8870
Fax: 60-4-227-4068

Philippines - Manila
Tel: 63-2-634-9065
Fax: 63-2-634-9069

Singapore
Tel: 65-6334-8870
Fax: 65-6334-8850

Taiwan - Hsin Chu
Tel: 886-3-5778-366
Fax: 886-3-5770-955

Taiwan - Kaohsiung
Tel: 886-7-213-7830

Taiwan - Taipei
Tel: 886-2-2508-8600
Fax: 886-2-2508-0102

Thailand - Bangkok
Tel: 66-2-694-1351
Fax: 66-2-694-1350

EUROPE

Austria - Wels
Tel: 43-7242-2244-39
Fax: 43-7242-2244-393

Denmark - Copenhagen
Tel: 45-4450-2828
Fax: 45-4485-2829

France - Paris
Tel: 33-1-69-53-63-20
Fax: 33-1-69-30-90-79

Germany - Dusseldorf
Tel: 49-2129-3766400

Germany - Munich
Tel: 49-89-627-144-0
Fax: 49-89-627-144-44

Germany - Pforzheim
Tel: 49-7231-424750

Italy - Milan
Tel: 39-0331-742611
Fax: 39-0331-466781

Italy - Venice
Tel: 39-049-7625286

Netherlands - Drunen
Tel: 31-416-690399
Fax: 31-416-690340

Poland - Warsaw
Tel: 48-22-3325737

Spain - Madrid
Tel: 34-91-708-08-90
Fax: 34-91-708-08-91

Sweden - Stockholm
Tel: 46-8-5090-4654

UK - Wokingham
Tel: 44-118-921-5800
Fax: 44-118-921-5820

03/25/14