

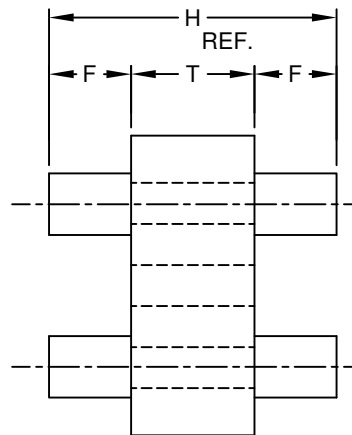

REV.	DESCRIPTION	DATE	APPROVED
C	Engineering Update w/o Changes	02/23/04	M. C.
D	Removed Material Code	05/22/16	J. C.

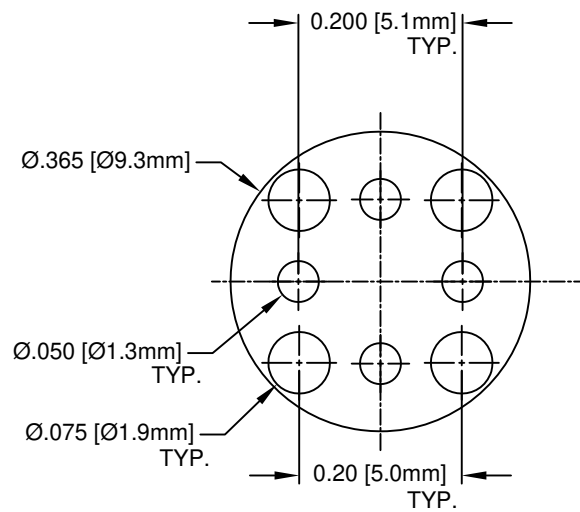

PART NO.	H	T	F
514-050	.050 (1.3)	.030 (.76)	.010 (.25)
514-060	.060 (1.5)	.030 (.76)	.015 (.38)
514-070	.070 (1.8)	.030 (.76)	.020 (.51)
514-080	.080 (2.0)	.030 (.76)	.025 (.64)
514-090	.090 (2.3)	.030 (.76)	.030 (.76)
514-100	.100 (2.5)	.030 (.76)	.035 (.89)
514-110	.110 (2.8)	.030 (.76)	.040 (1.0)
514-120	.120 (3.0)	.030 (.76)	.045 (1.1)
514-130	.130 (3.3)	.030 (.76)	.050 (1.3)
514-140	.140 (3.6)	.030 (.76)	.055 (1.4)
514-150	.150 (3.8)	.030 (.76)	.060 (1.5)
514-160	.160 (4.1)	.030 (.76)	.065 (1.7)
514-170	.170 (4.3)	.030 (.76)	.070 (1.8)
514-180	.180 (4.6)	.030 (.76)	.075 (1.9)
514-190	.190 (4.8)	.030 (.76)	.080 (2.0)
514-200	.200 (5.1)	.030 (.76)	.085 (2.2)
514-210	.210 (5.3)	.030 (.76)	.090 (2.3)
514-220	.220 (5.6)	.030 (.76)	.095 (2.4)
514-230	.230 (5.8)	.030 (.76)	.100 (2.5)
514-240	.240 (6.1)	.030 (.76)	.105 (2.7)

2. MATERIAL: NYLON 6/6, 94V-2, WHITE.

1. GENERAL SPECIFICATIONS: BIVAR MOLDED COMPONENT SPECIFICATION BV00-E101.

STANDARD TOLERANCE ( UNLESS OTHERWISE SPECIFIED )		 4 THOMAS, IRVINE, CA. 92618 TEL: (949) 951-8808 FAX: (949) 951-3974			
DECIMALS	ANGULAR				
.X ± .1	X° ± 1°	 <b>TITLE:</b> PERM-O-PAD TO-5 MOUNT			
.XX ± .01					
.XXX ± .005		DESIGNED: <b>D. Green</b>	DATE: <b>01/16/03</b>	<b>PART NO:</b> 514-XXX	REVISION: <b>D</b>
		CHECKED: <b>M. Chen</b>	DATE: <b>01/16/03</b>		<b>CAGE CODE : 32559</b>
CAD GENERATED DOCUMENT, DO NOT MEASURE DRAWING.					