

T H E R M O M E T R I C S
A C O M M I T M E N T T O E X C E L L E N C E

NTC Cryogenics

Thermometrics

Thermistors



Applications

All Cryogenic Type Thermistor probes are designed for use in the range of 77°F (room temperature) to -320.8°F (the boiling point of Liquid Nitrogen) (25°C to -196°C). These units are very stable, exhibit no hysteresis effects, and rapid temperature cycling from 77°F to -320.8°F (25°C to -196°C) has no measurable effect on electrical, thermal or mechanical properties. These units are well suited for Cryogenic control applications such as liquid level in the 77°F to -320.8°F (25°C to -196°C) range. They may be used at temperatures below the Nitrogen Point with suitable instrumentation.

Description

Cryogenic thermistor probes consist of a pressed disc thermistor attached to #27 AWG silver lead wires.

Data

Cryogenic type thermistor probes may be exposed to 221°F (105°C) for short periods; however, long term storage at or above 140°F (60°C) may result in some resistance change, therefore storage below 140°F (60°C) is recommended for best stability.

Amphenol
Advanced Sensors

Cryogenics Specifications

Thermal And Electrical Properties

Table A: RL Cryogenics

Type	Operation In Liquid	Resistance (Ω)	Temp. Coef. %/K	Fig.	Diss. Constant mW/K
RL1004-10K-0-S1	Oxygen	10K \pm 20%	-8.4	1	4
	Nitrogen	31.5K Nominal	-10.4		

Dissipation constant is in still air (mW/K)

Cryogenic Probes –Type RL

These cryogenic thermistors are extremely useful for liquid level detection in various cryogenic liquids. In this application, the thermistor is slightly self-heated by passing a small current through the unit. The heat generated in the unit is more easily dissipated when the thermistor is immersed in cryogenic fluid than when the fluid level falls below the thermistor. The resulting change in thermistor temperature is easily detected by the change in resistance.

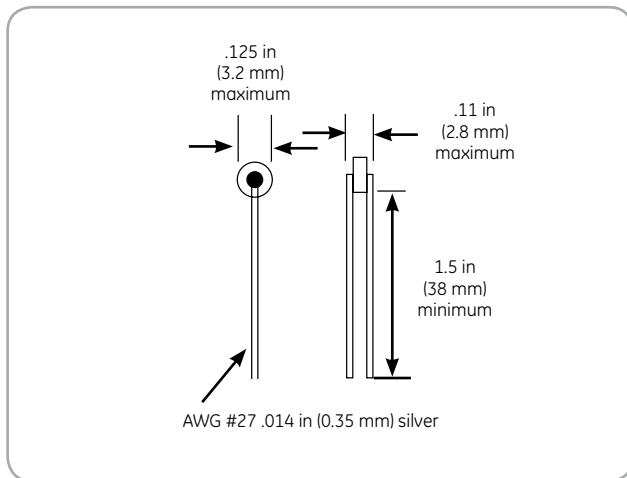

Figure 1