

**BFX89
BFY90**

**SILICON
NPN RF TRANSISTORS**



TO-72 CASE



www.centrasemi.com

DESCRIPTION:

The CENTRAL SEMICONDUCTOR BFX89 and BFY90 are silicon NPN RF transistors designed for VHF/UHF amplifier, oscillator and converter applications.

MARKING: FULL PART NUMBER

MAXIMUM RATINGS: ($T_A=25^\circ\text{C}$ unless otherwise noted)

	SYMBOL		UNITS
Collector-Base Voltage	V_{CBO}	30	V
Collector-Emitter Voltage	V_{CER}	30	V
Collector-Emitter Voltage	V_{CEO}	15	V
Emitter-Base Voltage	V_{EBO}	2.5	V
Continuous Collector Current	I_C	25	mA
Peak Collector Current ($f \geq 1.0\text{MHz}$)	I_{CM}	50	mA
Power Dissipation	P_D	200	mW
Power Dissipation ($T_C=25^\circ\text{C}$)	P_D	300	mW
Operating and Storage Junction Temperature	T_J, T_{stg}	-65 to +200	$^\circ\text{C}$
Thermal Resistance	θ_{JA}	875	$^\circ\text{C/W}$
Thermal Resistance	θ_{JC}	583	$^\circ\text{C/W}$

ELECTRICAL CHARACTERISTICS: ($T_A=25^\circ\text{C}$ unless otherwise noted)

SYMBOL	TEST CONDITIONS	BFX89			BFY90			UNITS
		MIN	TYP	MAX	MIN	TYP	MAX	
I_{CBO}	$V_{CB}=15\text{V}$	-	-	10	-	-	10	nA
BV_{CBO}	$I_C=10\mu\text{A}$	30	-	-	30	-	-	V
BV_{CER}	$I_C=1.0\text{mA}, R_{BE}=50\Omega$	30	-	-	30	-	-	V
BV_{CEO}	$I_C=1.0\text{mA}$	15	-	-	15	-	-	V
BV_{EBO}	$I_E=10\mu\text{A}$	2.5	-	-	2.5	-	-	V
h_{FE}	$V_{CE}=1.0\text{V}, I_C=2.0\text{mA}$	20	-	150	25	-	150	
h_{FE}	$V_{CE}=1.0\text{V}, I_C=25\text{mA}$	20	-	125	20	-	125	
f_T	$V_{CE}=5.0\text{V}, I_C=2.0\text{mA}, f=500\text{MHz}$	-	1.0	-	1.0	1.1	-	GHz
f_T	$V_{CE}=5.0\text{V}, I_C=25\text{mA}, f=500\text{MHz}$	-	1.2	-	1.3	1.4	-	GHz
C_{ob}	$V_{CB}=10\text{V}, I_E=0, f=1.0\text{MHz}$	-	-	1.7	-	-	1.5	pF
C_{re}	$V_{CE}=5.0\text{V}, I_C=2.0\text{mA}, f=1.0\text{MHz}$	-	0.6	-	-	0.6	0.8	pF
G_{pe}	$V_{CE}=10\text{V}, I_C=8.0\text{mA}, f=200\text{MHz}$	-	19	22	-	-	-	dB
G_{pe}	$V_{CE}=10\text{V}, I_C=8.0\text{mA}, f=800\text{MHz}$	-	-	7.0	-	-	-	dB
G_{pe}	$V_{CE}=10\text{V}, I_C=14\text{mA}, f=200\text{MHz}$	-	-	-	21	23	-	dB
G_{pe}	$V_{CE}=10\text{V}, I_C=14\text{mA}, f=800\text{MHz}$	-	-	-	-	8.0	-	dB

R4 (13-March 2014)

**BFX89
BFY90**

**SILICON
NPN RF TRANSISTORS**



ELECTRICAL CHARACTERISTICS - Continued: ($T_A=25^{\circ}\text{C}$ unless otherwise noted)

SYMBOL	TEST CONDITIONS	BFX89			BFY90			UNITS
		MIN	TYP	MAX	MIN	TYP	MAX	
NF	$V_{CE}=5.0\text{V}$, $I_C=2.0\text{mA}$, $f=100\text{kHz}$	-	-	-	-	-	4.0	dB
NF	$V_{CE}=5.0\text{V}$, $I_C=2.0\text{mA}$, $f=200\text{MHz}$	-	3.3	4.0	-	2.5	3.5	dB
NF	$V_{CE}=5.0\text{V}$, $I_C=2.0\text{mA}$, $f=500\text{MHz}$, $R_G=50\Omega$	-	-	6.5	-	-	5.0	dB
NF	$V_{CE}=5.0\text{V}$, $I_C=2.0\text{mA}$, $f=800\text{MHz}$	-	7.0	-	-	5.5	-	dB
P_o	$V_{CE}=10\text{V}$, $I_C=8.0\text{mA}$, $f=205\text{MHz}$	-	6.0	-	-	-	-	mW
P_o	$V_{CE}=10\text{V}$, $I_C=14\text{mA}$, $f=205\text{MHz}$	-	-	-	10	12	-	mW

TO-72 CASE - MECHANICAL OUTLINE

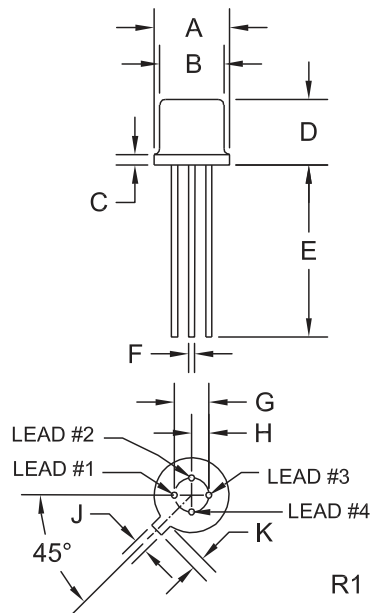

SYMBOL	DIMENSIONS			
	INCHES		MILLIMETERS	
	MIN	MAX	MIN	MAX
A (DIA)	0.209	0.230	5.31	5.84
B (DIA)	0.175	0.195	4.45	4.95
C	-	0.030	-	0.76
D	0.170	0.210	4.32	5.33
E	0.500	-	12.70	-
F (DIA)	0.016	0.019	0.41	0.48
G (DIA)	0.100		2.54	
H	0.050		1.27	
J	0.036	0.046	0.91	1.17
K	0.028	0.048	0.71	1.22

TO-72 (REV: R1)

LEAD CODE:

- 1) Emitter
- 2) Base
- 3) Collector
- 4) Case

**MARKING:
FULL PART NUMBER**

R4 (13-March 2014)

OUTSTANDING SUPPORT AND SUPERIOR SERVICES



PRODUCT SUPPORT

Central's operations team provides the highest level of support to insure product is delivered on-time.

- Supply management (Customer portals)
- Inventory bonding
- Consolidated shipping options
- Custom bar coding for shipments
- Custom product packing

DESIGNER SUPPORT/SERVICES

Central's applications engineering team is ready to discuss your design challenges. Just ask.

- Free quick ship samples (2nd day air)
- Online technical data and parametric search
- SPICE models
- Custom electrical curves
- Environmental regulation compliance
- Customer specific screening
- Up-screening capabilities
- Special wafer diffusions
- PbSn plating options
- Package details
- Application notes
- Application and design sample kits
- Custom product and package development

REQUESTING PRODUCT PLATING

1. If requesting Tin/Lead plated devices, add the suffix "TIN/LEAD" to the part number when ordering (example: 2N2222A TIN/LEAD).
2. If requesting Lead (Pb) Free plated devices, add the suffix "PBFREE" to the part number when ordering (example: 2N2222A PBFREE).

CONTACT US

Corporate Headquarters & Customer Support Team

Central Semiconductor Corp.
145 Adams Avenue
Hauppauge, NY 11788 USA
Main Tel: (631) 435-1110
Main Fax: (631) 435-1824
Support Team Fax: (631) 435-3388
www.centrasemi.com

Worldwide Field Representatives:
www.centrasemi.com/wwreps

Worldwide Distributors:
www.centrasemi.com/wwdistributors

For the latest version of Central Semiconductor's **LIMITATIONS AND DAMAGES DISCLAIMER**, which is part of Central's Standard Terms and Conditions of sale, visit: www.centrasemi.com/terms