

REV.	DATE	ECR NO.	DESCRIPTION
NC	07/06/12	XXXXXX	INITIAL RELEASE
A	08/20/12	XXXXXX	UPDATE NOTE 4
B	09/19/12	2373	CHANGE THE DESIGN

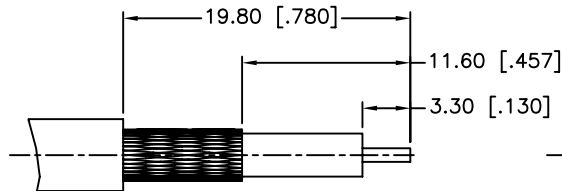

RECOMMENDED  
CABLE STRIPPING DIM'S

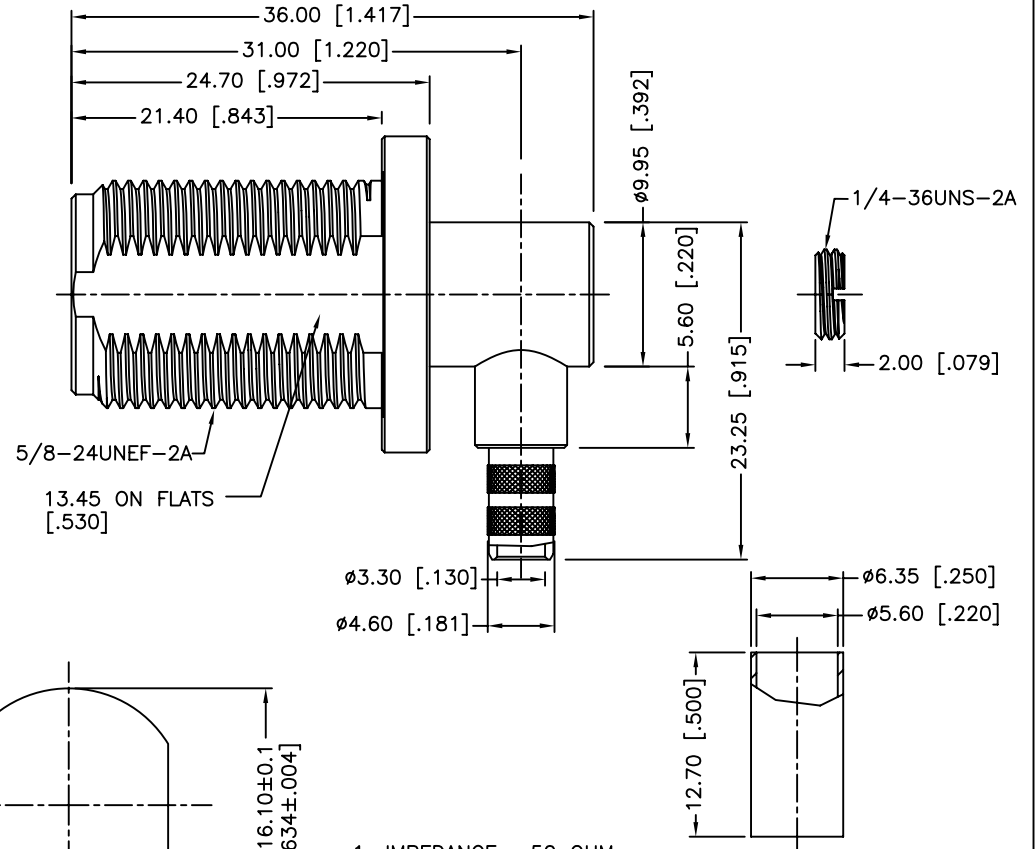
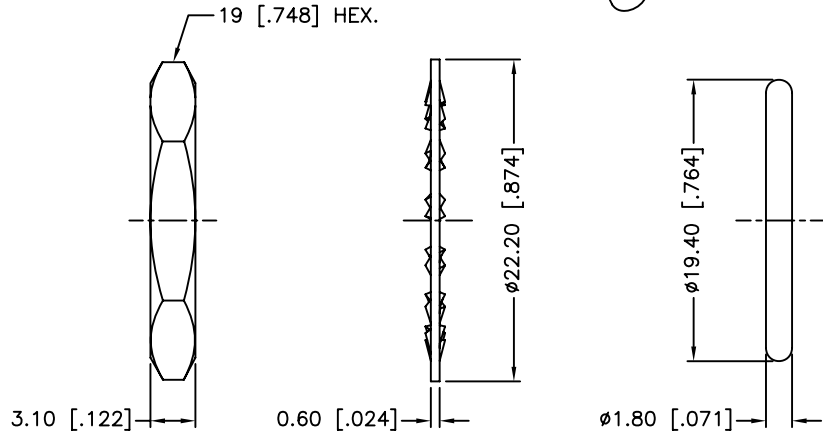
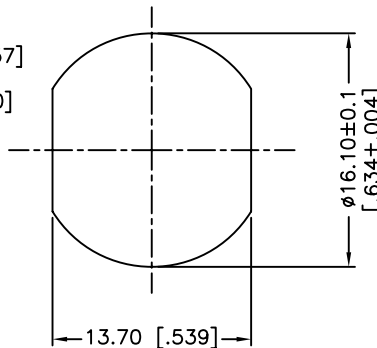

RECOMMENDED  
MOUNTING HOLE

1. IMPEDANCE: 50 OHM
2. FREQUENCY RANGE: DC-6 GHz
3. VSWR: 1.3 MAX.
4. DIELECTRIC WITHSTANDING VOLTAGE: 1500 VRMS, MIN.
5. DURABILITY: 500 CYCLES MIN.
6. TEMPERATURE RANGE: -65°C TO +165°C
7. CRIMPED FERRULE:  
HEX. CRIMP SIZE .213"
8. CONTACT PIN MUST BE SOLDERED
9. MAX. PANEL THICKNESS=7mm

DESCRIPTION	MATERIAL	FINISH	QTY
9	FERRULE	BRASS	NEXCOTE 1
8	HEX NUT	BRASS	NEXCOTE 1
7	LOCK WASHER	BRASS	NEXCOTE 1
6	GASKET	SILICON RUBBER	RED 1
5	COVER	BRASS	NEXCOTE 1
4	INSULATOR	PTFE	NATURAL 1
3	CONTACT PIN	PHOSPHOR BRONZE	GOLD 1
2	INNER BODY	BRASS	NEXCOTE 1
1	BODY	BRASS	NEXCOTE 1

UNLESS OTHERWISE SPECIFIED DIMENSIONS ARE IN MILLIMETERS. DIMENSIONS IN [ ] ARE IN INCHES AND FOR CUSTOMER REFERENCE ONLY.

UNLESS OTHERWISE SPECIFIED TOLERANCES FOR MILLIMETERS ARE:  
0.5 - 8mm ± 0.20mm  
8 - 30mm ± 0.40mm  
30 - 120mm ± 0.50mm

UNLESS OTHERWISE SPECIFIED TOLERANCES FOR INCHES ARE:  
.020 - .315 ± 0.007"  
.315 - 1.180 ± 0.015"  
1.180 - 4.724 ± 0.020"

DO NOT SCALE DRAWING

APPROVALS	DATE
DRAWN M.ZHANG	09/19/12
CHECKED	
ISSUED	
SHEET 1 OF 1	
CAD FILE C:/CONNEX/172368.DWG	

**Amphenol Connex**

PART DESCRIPTION  
**N BULKHEAD R/A JACK  
(FOR LMR-195 CABLE)**

PART NO.  
**172368**

DWG. NO. 172368.DWG	REV. B	SIZE A	SCALE NA
---------------------	--------	--------	----------