

P	LTR	DESCRIPTION	DATE	DWN	APVD
M		REV PER ECN-22-157758	21JUN2022	JAB	PJD

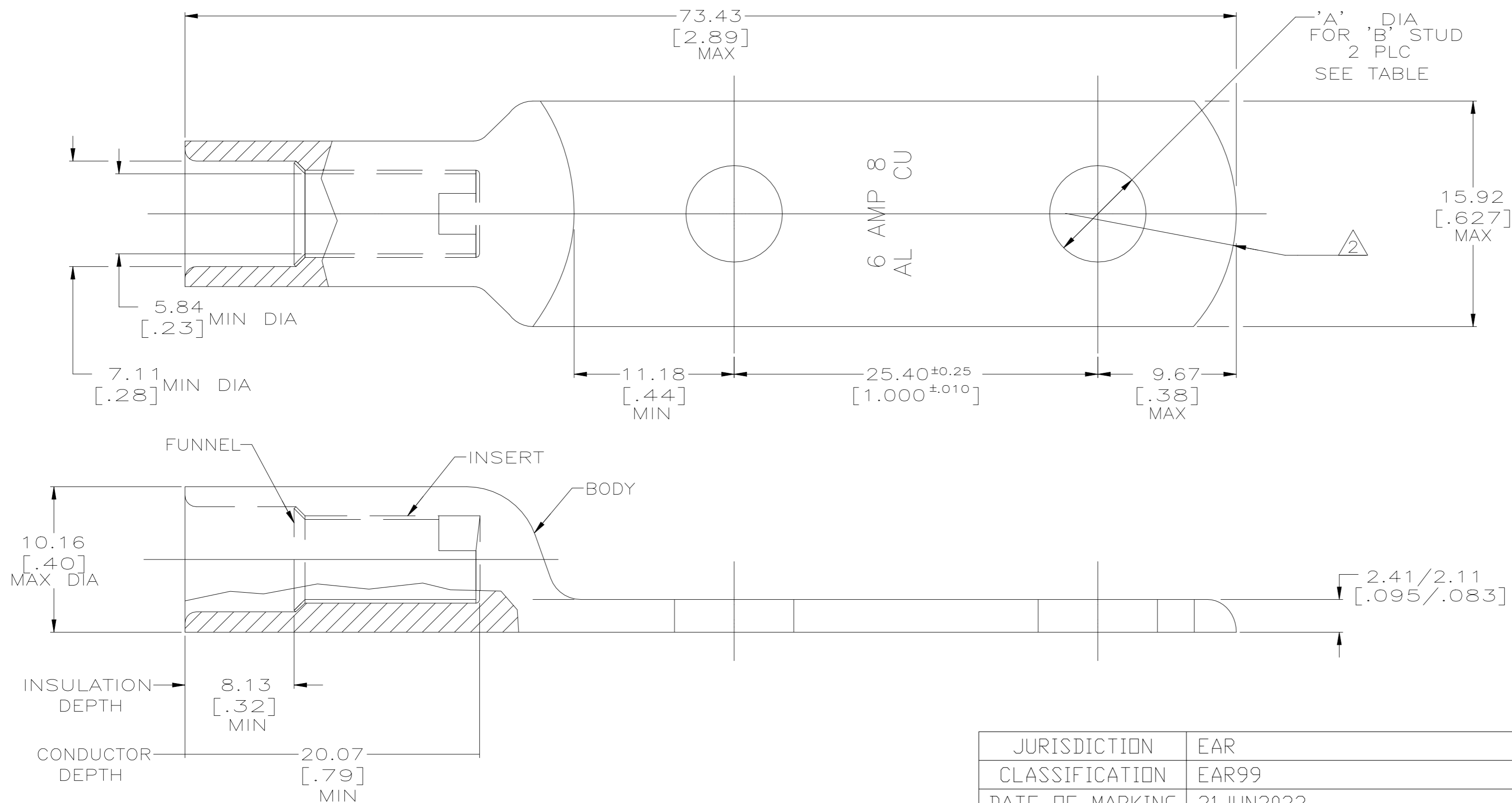

JURISDICTION	EAR
CLASSIFICATION	EAR99
DATE OF MARKING	21JUN2022
THIS DOCUMENT CONTAINS CONTROLLED TECHNICAL DATA SUBJECT TO THE EXPORT ADMINISTRATION REGULATIONS (EAR). VIOLATIONS OF THESE EXPORT LAWS AND REGULATIONS ARE SUBJECT TO CIVIL AND CRIMINAL PENALTIES.	

- 1 WIRE INSULATION: 5.72[.225] – 6.35[.250] DIA
- 2 THE TONGUE RADIUS FEATURE IS NOT A TOOLING CONTROLLED DIMENSION AND MAY NOT BE A TRUE RADIUS.
- 3 IF USING COPPER WIRE, HEAT SHRINK TUBING MAY BE REQUIRED TO BUILD UP THE INSULATION RANGE IN ORDER TO MEET THE REQUIRED INSULATION RANGE.
- 4 SEE TE CONNECTIVITY INSTRUCTION SHEET 408-2281 FOR TOOLING AND CRIMP INSTRUCTIONS, FIGURE 2 FOR WIRE STRIPPING DETAIL.

23 GRAMS	9.9 ^{+0.13} [.390 ± 0.005]	3/8	BODY: COPPER ASTM-B187 ANNEALED TIN PL MIL-T-10727 0.00457[.000150] MIN THK	55832-2
OBSOLETE	6.73 ^{+0.08} [.265 ± 0.003]	1/4	INSERT & FUNNEL: BRASS PER ASTM B36 NICKEL PLATE SAE AMS QQ-N-290A, DATED JULY 2000, 0.00254 [.000100] MIN THK	55832-1
WEIGHT	"A"	"B"	MATERIAL AND FINISH	PART NO.

THIS DRAWING IS A CONTROLLED DOCUMENT.

DIMENSIONS: MM [INCHES]	TOLERANCES UNLESS OTHERWISE SPECIFIED:	DWN DK_SCHRUM 6/15/92	
	0 PLC ± -	CHK WJ_VOCKROTH 6/16/92	
	1 PLC ± -	APVD AJ_KAUFMAN 6/16/92	
	2 PLC ± -	NAME	
	3 PLC ± -	PRODUCT SPEC 108-11011	WIRE TERMINAL, COPALUM SEALED, RING TONGUE, WIRE SIZE: 6 AL, 4 COPPER
	4 PLC ± -	APPLICATION SPEC 114-2134	SIZE CAGE CODE DRAWING NO
	ANGLES ± -	WEIGHT 0.000000	A2 00779 C=55832
MATERIAL SEE TABLE	FINISH SEE TABLE	CUSTOMER DRAWING	RESTRICTED TO -
		SCALE 4:1	SHEET 1 OF 1
		REV M	