



## CMOS Static RAM 256K (32K x 8-Bit)

**IDT71256S**  
**IDT71256L**

### Features

- ◆ High-speed address/chip select time
  - Military: 25/35/45/55/70/85/100ns (max.)
  - Commercial/Industrial: 20/25/35ns (max.) low power only
- ◆ Low-power operation
- ◆ Battery Backup operation – 2V data retention
- ◆ Produced with advanced high-performance CMOS technology
- ◆ Input and output directly TTL-compatible
- ◆ Available in standard 28-pin (300 or 600 mil) ceramic DIP, 28-pin (300 mil) SOJ
- ◆ Military product compliant to MIL-STD-883, Class B

### Description

The IDT71256 is a 262,144-bit high-speed static RAM organized as 32K x 8. It is fabricated using high-performance, high-reliability CMOS technology.

Address access times as fast as 20ns are available with power consumption of only 350mW (typ.). The circuit also offers a reduced power standby mode. When  $\overline{CS}$  goes HIGH, the circuit will automatically go to and remain in, a low-power standby mode as long as  $\overline{CS}$  remains HIGH. This capability provides significant system level power and cooling savings. The low-power (L) version also offers a battery backup data retention capability where the circuit typically consumes only 5 $\mu$ W when operating off a 2V battery.

The IDT71256 is packaged in a 28-pin (300 or 600 mil) ceramic DIP, a 28-pin 300 mil SOJ providing high board level packing densities.

The IDT71256 military RAM is manufactured in compliance with the latest revision of MIL-STD-883, Class B, making it ideally suited to military temperature applications demanding the highest level of performance and reliability.

### Functional Block Diagram

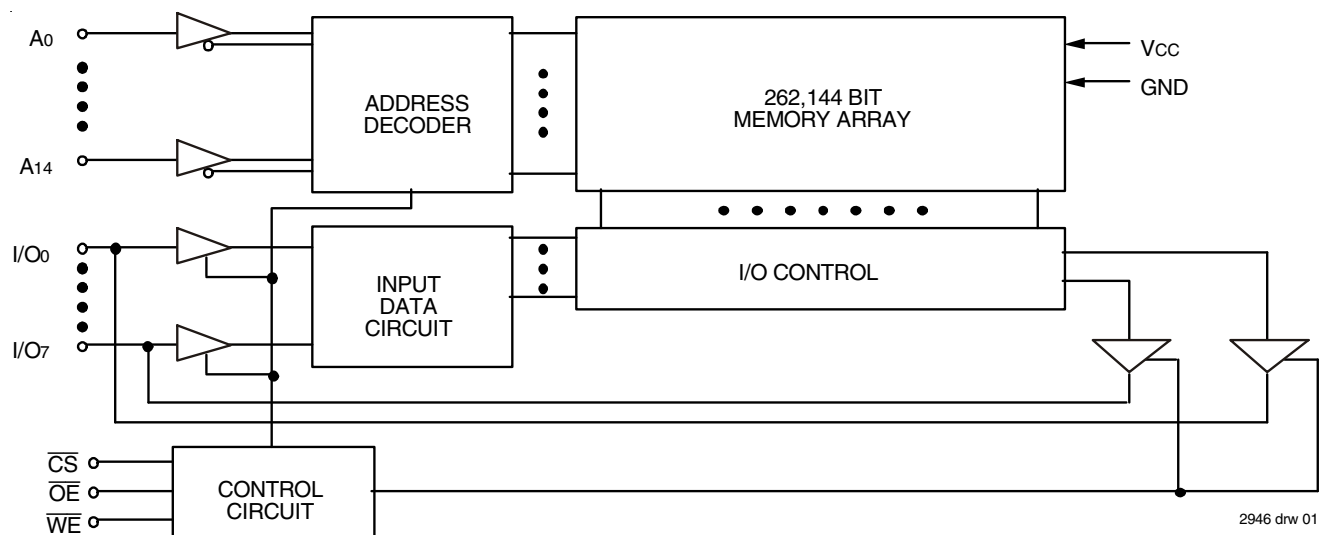

SEPTEMBER 2013

## Pin Configurations

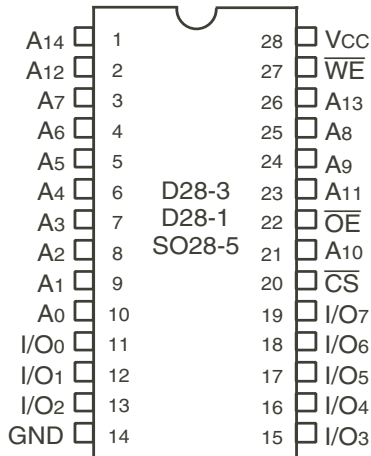

2946 drw 02

### DIP/SOJ Top View

## Pin Descriptions

Name	Description
A <sub>0</sub> - A <sub>14</sub>	Address Inputs
I/O <sub>0</sub> - I/O <sub>7</sub>	Data Input/Output
$\overline{CS}$	Chip Select
$\overline{WE}$	Write Enable
$\overline{OE}$	Output Enable
GND	Ground
V <sub>CC</sub>	Power

2946 tbl 01

## Truth Table<sup>(1)</sup>

$\overline{WE}$	$\overline{CS}$	$\overline{OE}$	I/O	Function
X	H	X	High-Z	Standby (ISB)
X	V <sub>HC</sub>	X	High-Z	Standby (ISB <sub>1</sub> )
H	L	H	High-Z	Output Disabled
H	L	L	DOUT	Read Data
L	L	X	DIN	Write Data

2946 tbl 02

NOTE:

- H = V<sub>IH</sub>, L = V<sub>IL</sub>, X = Don't care.

## Absolute Maximum Ratings<sup>(1)</sup>

Symbol	Rating	Com'l.	Ind.	Mil.	Unit
V <sub>TERM</sub>	Terminal Voltage with Respect to GND	-0.5 to +7.0	-0.5 to +7.0	-0.5 to +7.0	V
T <sub>A</sub>	Operating Temperature	0 to +70	-40 to +85	-55 to +125	°C
T <sub>BIAS</sub>	Temperature Under Bias	-55 to +125	-55 to +125	-65 to +135	°C
T <sub>STG</sub>	Storage Temperature	-55 to +125	-55 to +125	-65 to +150	°C
P <sub>T</sub>	Power Dissipation	1.0	1.0	1.0	W
I <sub>OUT</sub>	DC Output Current	50	50	50	mA

2946 tbl 03

NOTE:

- Stresses greater than those listed under ABSOLUTE MAXIMUM RATINGS may cause permanent damage to the device. This is a stress rating only and functional operation of the device at these or any other conditions above those indicated in the operational sections of this specification is not implied. Exposure to absolute maximum rating conditions for extended periods may affect reliability.

## Capacitance (T<sub>A</sub> = +25°C, f = 1.0MHz)

Symbol	Parameter <sup>(1)</sup>	Conditions	Max.	Unit
C <sub>IN</sub>	Input Capacitance	V <sub>IN</sub> = 0V	11	pF
C <sub>I/O</sub>	I/O Capacitance	V <sub>OUT</sub> = 0V	11	pF

2946 tbl 04

NOTE:

- This parameter is determined by device characterization, but is not production tested.

### Recommended Operating Temperature and Supply Voltage

Grade	Temperature	GND	Vcc
Military	-55°C to +125°C	0V	5V ± 10%
Industrial	-40°C to +85°C	0V	5V ± 10%
Commercial	0°C to +70°C	0V	5V ± 10%

2946 tbl 05

### Recommended DC Operating Conditions

Symbol	Parameter	Min.	Typ.	Max.	Unit
Vcc	Supply Voltage	4.5	5.0	5.5	V
GND	Ground	0	0	0	V
V <sub>IH</sub>	Input High Voltage	2.2	—	6.0	V
V <sub>IL</sub>	Input Low Voltage	-0.5 <sup>(1)</sup>	—	0.8	V

2946 tbl 06

NOTE:

1. V<sub>IL</sub> (min.) = -3.0V for pulse width less than 20ns, once per cycle.

### DC Electrical Characteristics<sup>(1,2)</sup> (V<sub>CC</sub> = 5.0V ± 10%, V<sub>LC</sub> = 0.2V, V<sub>HC</sub> = V<sub>CC</sub> - 0.2V)

Symbol	Parameter	Power	71256S/L20	71256S/L25	71256S/L35	71256S/L45	Unit		
			Com'l. & Ind	Com'l. & Ind	Mil.	Com'l. & Ind		Mil.	Mil.
ICC	Dynamic Operating Current CS ≤ V <sub>IL</sub> , Outputs Open V <sub>CC</sub> = Max., f <sub>MAX</sub> <sup>(2)</sup>	S	—	—	150	—	140	135	mA
		L	135	125	130	115	120	115	
ISB	Standby Power Supply Current (TTL Level), CS ≥ V <sub>IH</sub> , V <sub>CC</sub> = Max., Outputs Open, f = f <sub>MAX</sub> <sup>(2)</sup>	S	—	—	20	—	20	20	mA
		L	3	3	3	3	3	3	
ISB1	Full Standby Power Supply Current (CMOS Level), CS ≥ V <sub>HC</sub> , V <sub>CC</sub> = Max., f = 0	S	—	—	20	—	20	20	mA
		L	0.6	0.6	1.5	0.6	1.5	1.5	

2946 tbl 07

Symbol	Parameter	Power	71256S/L55	71256S/L70	71256S/L85	71256S/L100	Unit
			Mil.	Mil.	Mil.	Mil.	
ICC	Dynamic Operating Current CS ≤ V <sub>IL</sub> , Outputs Open V <sub>CC</sub> = Max., f <sub>MAX</sub> <sup>(2)</sup>	S	135	135	135	135	mA
		L	115	115	115	115	
ISB	Standby Power Supply Current (TTL Level), CS ≥ V <sub>IH</sub> , V <sub>CC</sub> = Max., Outputs Open, f = f <sub>MAX</sub> <sup>(2)</sup>	S	20	20	20	20	mA
		L	3	3	3	3	
ISB1	Full Standby Power Supply Current (CMOS Level), CS ≥ V <sub>HC</sub> , V <sub>CC</sub> = Max., f = 0	S	20	20	20	20	mA
		L	1.5	1.5	1.5	1.5	

2946 tbl 08

NOTES:

- All values are maximum guaranteed values.
- f<sub>MAX</sub> = 1/TRC, all address inputs are cycling at f<sub>MAX</sub>; f = 0 means no address pins are cycling.

## AC Test Conditions

Input Pulse Levels	GND to 3.0V
Input Rise/Fall Times	5ns
Input Timing Reference Levels	1.5V
Output Reference Levels	1.5V
AC Test Load	See Figures 1 and 2

2946 tbl 09

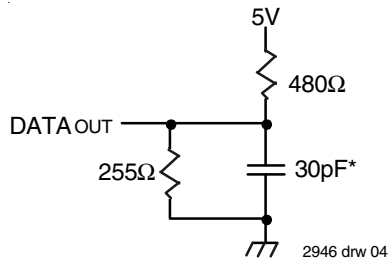

Figure 1. AC Test Load

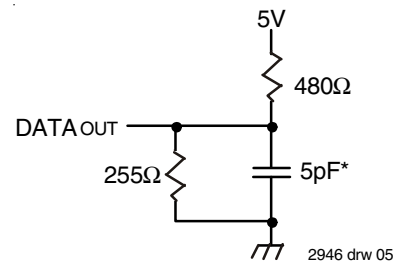

Figure 2. AC Test Load  
(for tCLZ, tOLZ, tCHZ, tOHZ, tOW, and tWHZ)

\*Includes scope and jig capacitances

## DC Electrical Characteristics (VCC = 5.0V ± 10%)

Symbol	Parameter	Test Conditions	IDT71256S			IDT71256L			Unit	
			Min.	Typ.	Max.	Min.	Typ.	Max.		
I <sub>LI</sub>	Input Leakage Current	V <sub>CC</sub> = Max., V <sub>IN</sub> = GND to V <sub>CC</sub>	MIL. COM*L & IND.	—	—	10 5	—	—	5 2	μA
I <sub>LO</sub>	Output Leakage Current	V <sub>CC</sub> = Max., $\overline{CS} = V_{IH}$ , V <sub>OUT</sub> = GND to V <sub>CC</sub>	MIL. COM*L & IND.	—	—	10 5	—	—	5 2	μA
V <sub>OL</sub>	Output Low Voltage	I <sub>OL</sub> = 8mA, V <sub>CC</sub> = Min.	—	—	0.4	—	—	0.4	V	
		I <sub>OL</sub> = 10mA, V <sub>CC</sub> = Min.	—	—	0.5	—	—	0.5	V	
V <sub>OH</sub>	Output High Voltage	I <sub>OH</sub> = -4mA, V <sub>CC</sub> = Min.	2.4	—	—	2.4	—	—	V	

2946 tbl 10

## Data Retention Characteristics Over All Temperature Ranges

(L Version Only) (V<sub>LC</sub> = 0.2V, V<sub>HC</sub> = V<sub>CC</sub> - 0.2V)

Symbol	Parameter	Test Condition	Min.	Typ. <sup>(1)</sup> V <sub>CC</sub> @		Max. V <sub>CC</sub> @		Unit
				2.0V	3.0V	2.0V	3.0V	
V <sub>DR</sub>	V <sub>CC</sub> for Data Retention	—	2.0	—	—	—	—	V
I <sub>CDR</sub>	Data Retention Current	MIL. COM*L. & IND.	—	—	—	500 120	800 200	μA
t <sub>CDR</sub>	Chip Deselect to Data Retention Time	$\overline{CS} \geq V_{HC}$	0	—	—	—	—	ns
t <sub>R</sub> <sup>(3)</sup>	Operation Recovery Time		t <sub>RC</sub> <sup>(2)</sup>	—	—	—	—	ns

2946 tbl 11

### NOTES:

- TA = +25°C.
- t<sub>RC</sub> = Read Cycle Time.
- This parameter is guaranteed by device characterization, but is not production tested.

## Low Vcc Data Retention Waveform

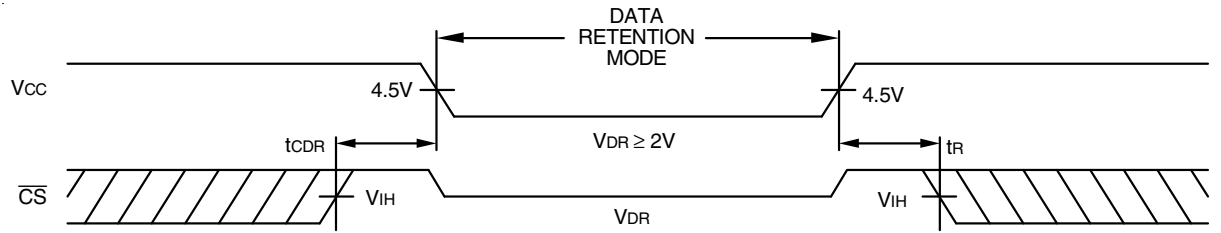

2946 drw 06

## AC Electrical Characteristics (Vcc = 5.0V ± 10%, All Temperature Ranges)

Symbol	Parameter	71256L20 <sup>(1)</sup>		71256S25 <sup>(3)</sup> 71256L25		71256S35 <sup>(3)</sup> 71256L35		71256S45 <sup>(3)</sup> 71256L45 <sup>(3)</sup>		Unit
		Min.	Max.	Min.	Max.	Min.	Max.	Min.	Max.	
<b>Read Cycle</b>										
t <sub>RC</sub>	Read Cycle Time	20	—	25	—	35	—	45	—	ns
t <sub>AA</sub>	Address Access Time	—	20	—	25	—	35	—	45	ns
t <sub>ACS</sub>	Chip Select Access Time	—	20	—	25	—	35	—	45	ns
t <sub>CLZ</sub> <sup>(2)</sup>	Chip Select to Output in Low-Z	5	—	5	—	5	—	5	—	ns
t <sub>CHZ</sub> <sup>(2)</sup>	Chip Deselect to Output in High-Z	—	10	—	11	—	15	—	20	ns
t <sub>OE</sub>	Output Enable to Output Valid	—	10	—	11	—	15	—	20	ns
t <sub>OLZ</sub> <sup>(2)</sup>	Output Enable to Output in Low-Z	2	—	2	—	2	—	0	—	ns
t <sub>OHZ</sub> <sup>(2)</sup>	Output Disable to Output in High-Z	2	8	2	10	2	15	—	20	ns
t <sub>OH</sub>	Output Hold from Address Change	5	—	5	—	5	—	5	—	ns
<b>Write Cycle</b>										
t <sub>WC</sub>	Write Cycle Time	20	—	25	—	35	—	45	—	ns
t <sub>CW</sub>	Chip Select to End-of-Write	15	—	20	—	30	—	40	—	ns
t <sub>AW</sub>	Address Valid to End-of-Write	15	—	20	—	30	—	40	—	ns
t <sub>AS</sub>	Address Set-up Time	0	—	0	—	0	—	0	—	ns
t <sub>WP</sub>	Write Pulse Width	15	—	20	—	30	—	35	—	ns
t <sub>WR</sub>	Write Recovery Time	0	—	0	—	0	—	0	—	ns
t <sub>DW</sub>	Data to Write Time Overlap	11	—	13	—	15	—	20	—	ns
t <sub>WHZ</sub> <sup>(2)</sup>	Write Enable to Output in High-Z	—	10	—	11	—	15	—	20	ns
t <sub>DH</sub>	Data Hold from Write Time	0	—	0	—	0	—	0	—	ns
t <sub>OW</sub> <sup>(2)</sup>	Output Active from End-of-Write	5	—	5	—	5	—	5	—	ns

2946 tbl 12

**NOTES:**

- 0° to +70°C or -40° to +85°C temperature range only.
- This parameter is guaranteed by device characterization, but is not production tested.
- 55°C to +125°C temperature range only.

## AC Electrical Characteristics (V<sub>CC</sub> = 5.0V ± 10%, Military Temperature Ranges)

Symbol	Parameter	71256S55 <sup>(1)</sup> 71256L55 <sup>(1)</sup>		71256S70 <sup>(1)</sup> 71256L70 <sup>(1)</sup>		71256S85 <sup>(1)</sup> 71256L85 <sup>(1)</sup>		71256S100 <sup>(1)</sup> 71256L100 <sup>(1)</sup>		Unit
		Min.	Max.	Min.	Max.	Min.	Max.	Min.	Max.	
<b>Read Cycle</b>										
t <sub>RC</sub>	Read Cycle Time	55	---	70	---	85	---	100	---	ns
t <sub>AA</sub>	Address Access Time	---	55	---	70	---	85	---	100	ns
t <sub>ACS</sub>	Chip Select Access Time	---	55	---	70	---	85	---	100	ns
t <sub>OLZ</sub> <sup>(2)</sup>	Chip Select to Output in Low-Z	5	---	5	---	5	---	5	---	ns
t <sub>CHZ</sub> <sup>(2)</sup>	Chip Deselect to Output in High-Z	---	25	---	30	---	35	---	40	ns
t <sub>OE</sub>	Output Enable to Output Valid	---	25	---	30	---	35	---	40	ns
t <sub>OLZ</sub> <sup>(2)</sup>	Output Enable to Output in Low-Z	0	---	0	---	0	---	0	---	ns
t <sub>OHZ</sub> <sup>(2)</sup>	Output Disable to Output in High-Z	0	25	0	30	---	35	---	40	ns
t <sub>OH</sub>	Output Hold from Address Change	5	---	5	---	5	---	5	---	ns
<b>Write Cycle</b>										
t <sub>WC</sub>	Write Cycle Time	55	---	70	---	85	---	100	---	ns
t <sub>CW</sub>	Chip Select to End-of-Write	50	---	60	---	70	---	80	---	ns
t <sub>AW</sub>	Address Valid to End-of-Write	50	---	60	---	70	---	80	---	ns
t <sub>AS</sub>	Address Set-up Time	0	---	0	---	0	---	0	---	ns
t <sub>WP</sub>	Write Pulse Width	40	---	45	---	50	---	55	---	ns
t <sub>WR</sub>	Write Recovery Time	0	---	0	---	0	---	0	---	ns
t <sub>DW</sub>	Data to Write Time Overlap	25	---	30	---	35	---	40	---	ns
t <sub>WHZ</sub> <sup>(2)</sup>	Write Enable to Output in High-Z	---	25	---	30	---	35	---	40	ns
t <sub>DH</sub>	Data Hold from Write Time ( $\overline{WE}$ )	0	---	0	---	0	---	0	---	ns
t <sub>OW</sub> <sup>(2)</sup>	Output Active from End-of-Write	5	---	5	---	5	---	5	---	ns

NOTES:

- 55° to +125°C temperature range only.
- This parameter is guaranteed by device characterization, but is not production tested.

2946 tbi 13

### Timing Waveform of Read Cycle No. 1<sup>(1)</sup>

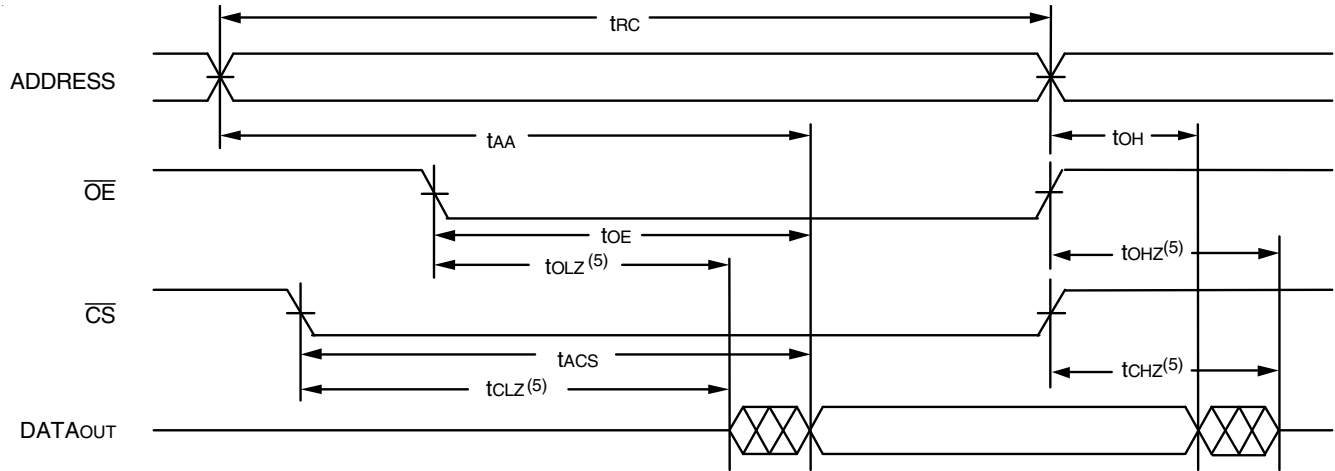

2946 drw 07

### Timing Waveform of Read Cycle No. 2<sup>(1,2,4)</sup>

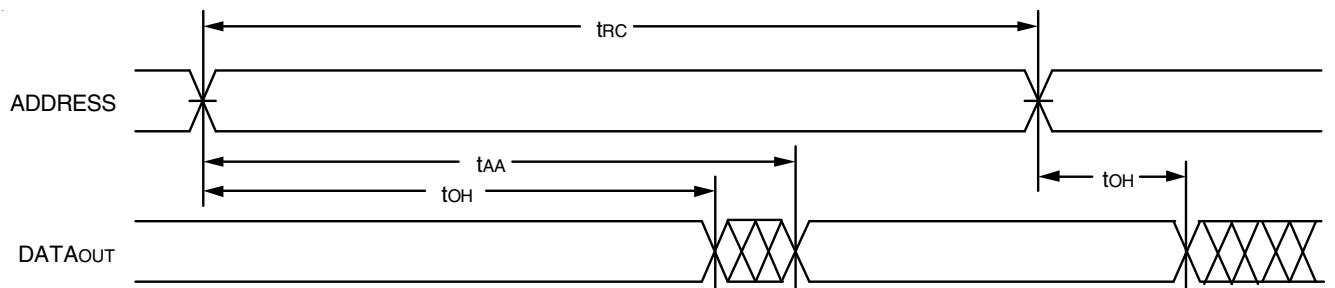

2946 drw 08

### Timing Waveform of Read Cycle No. 2<sup>(1,3,4)</sup>

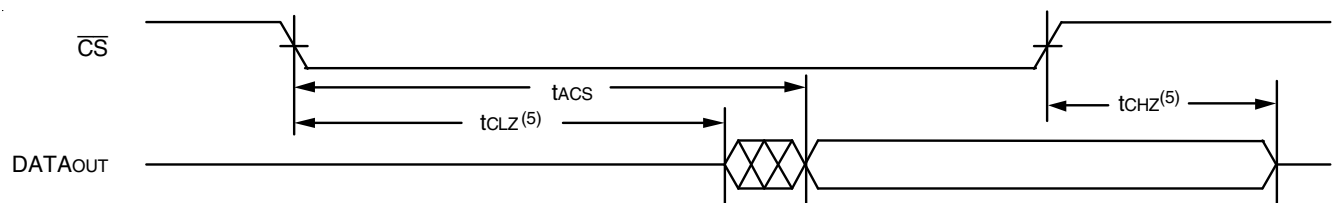

2946 drw 09

NOTES:

1.  $\overline{WE}$  is HIGH for Read Cycle.
2. Device is continuously selected,  $\overline{CS}$  is LOW.
3. Address valid prior to or coincident with  $\overline{CS}$  transition LOW.
4.  $\overline{OE}$  is LOW.
5. Transition is measured  $\pm 200\text{mV}$  from steady state.

### Timing Waveform of Write Cycle No. 1 ( $\overline{WE}$ Controlled Timing)<sup>(1,2,4,6)</sup>

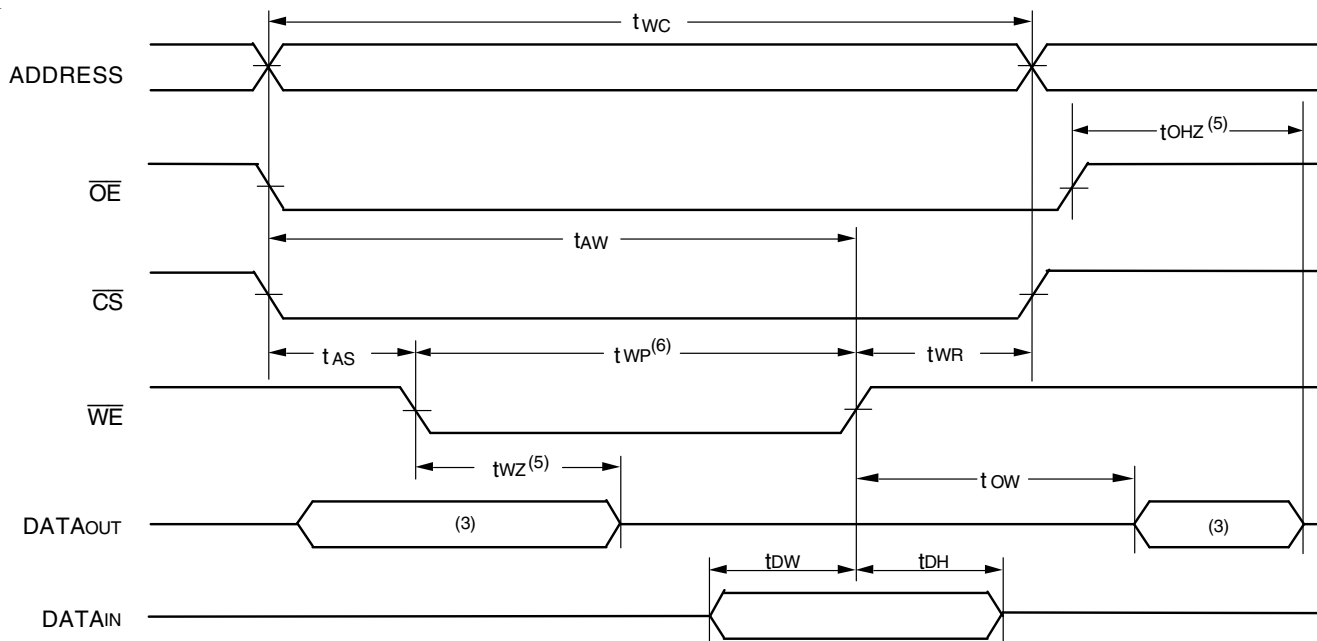

2946 drw 10

### Timing Waveform of Write Cycle No. 2 ( $\overline{CS}$ Controlled Timing)<sup>(1,2,4)</sup>

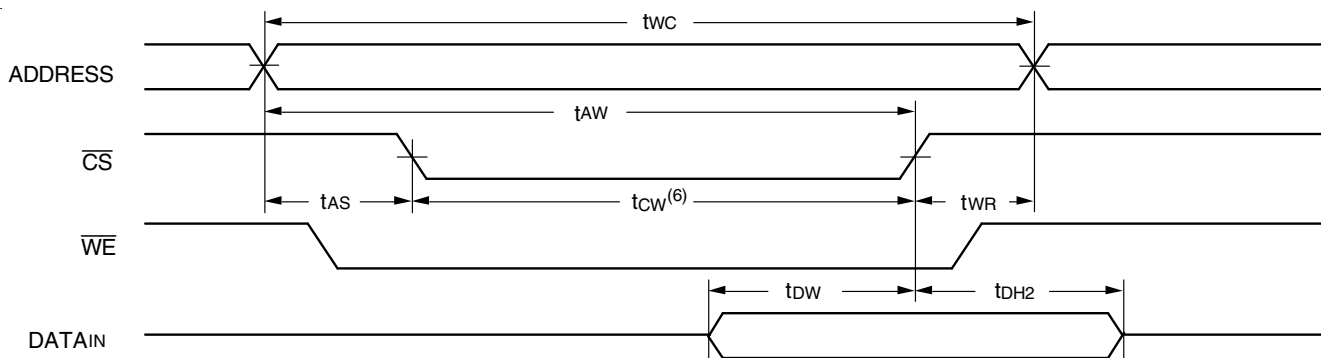

2946 drw 11

NOTES:

1. A write occurs during the overlap of a LOW  $\overline{CS}$  and a LOW  $\overline{WE}$ .
2.  $t_{WR}$  is measured from the earlier of  $\overline{CS}$  or  $\overline{WE}$  going HIGH to the end of the write cycle.
3. During this period, I/O pins are in the output state so that the input signals must not be applied.
4. If the  $\overline{CS}$  LOW transition occurs simultaneously with or after the  $\overline{WE}$  LOW transition, the outputs remain in a high-impedance state.
5. Transition is measured  $\pm 200\text{mV}$  from steady state.
6. If  $\overline{OE}$  is LOW during a  $\overline{WE}$  controlled write cycle, the write pulse width must be the larger of  $t_{WP}$  or  $(t_{WHZ} + t_{DW})$  to allow the I/O drivers to turn off and data to be placed on the bus for the required  $t_{DW}$ . If  $\overline{OE}$  is HIGH during a  $\overline{WE}$  controlled write cycle, this requirement does not apply and the minimum write pulse width can be as short as the specified  $t_{WP}$ . For a  $\overline{CS}$  controlled write cycle,  $\overline{OE}$  may be LOW with no degradation to  $t_{CW}$ .



### Ordering Information — Commercial & Industrial

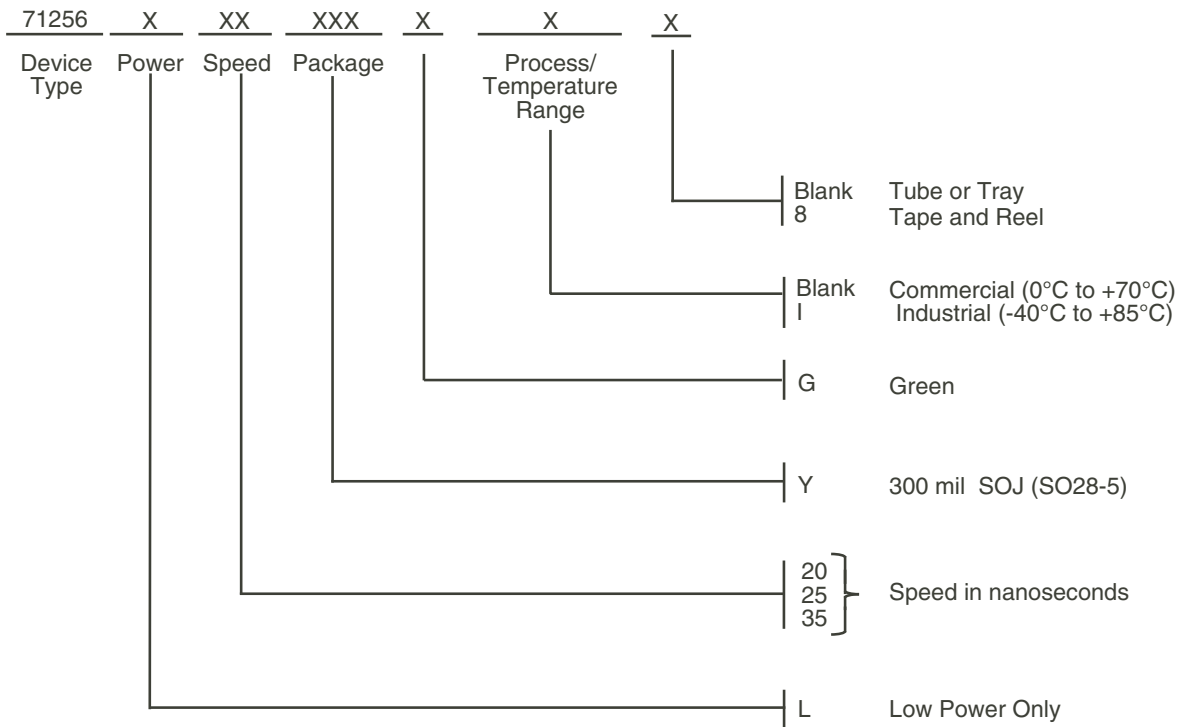

2946 drw 13

### Ordering Information — Military

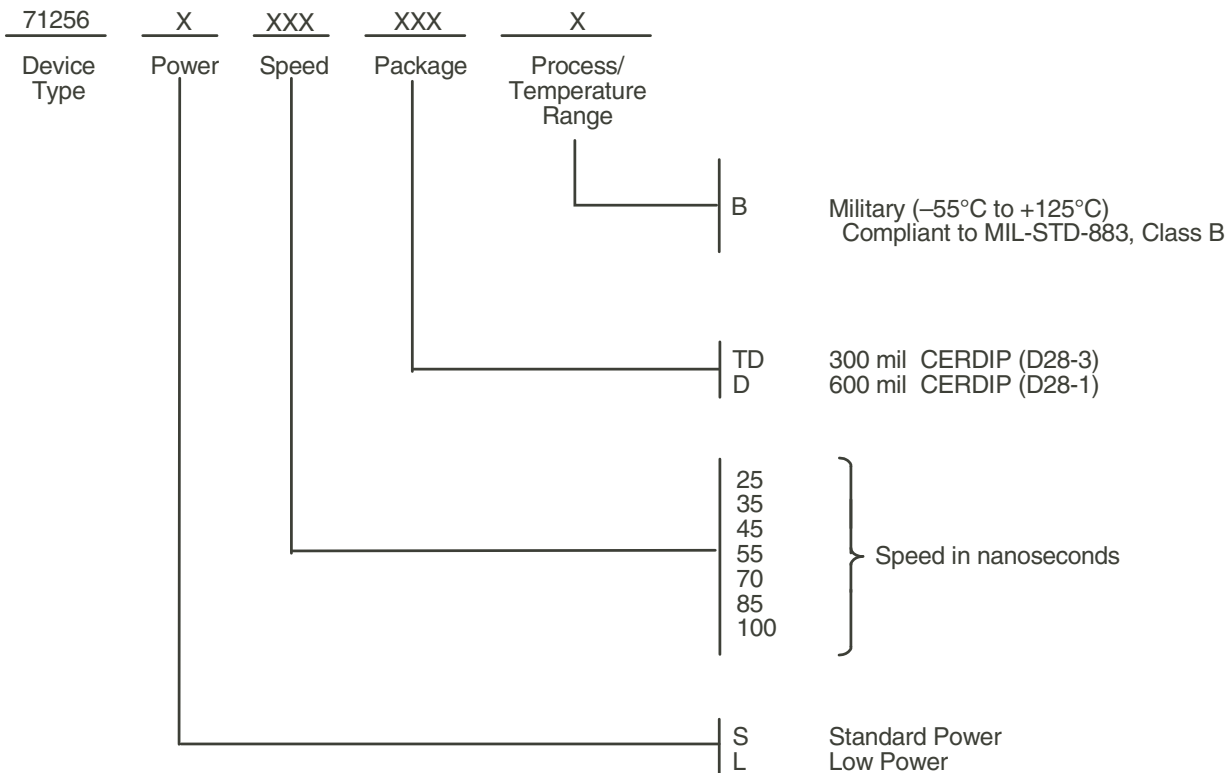

2946 drw 12

## Datasheet Document History

11/4/99:		Updated to new format
	Pp. 1–5, 9	Added Industrial Temperature Range offerings
	Pg. 1	Removed 30, 120, and 150ns military and 45ns commercial speed grade offerings.
	Pg. 2	Removed P28-2 package from DIP/SOJ Top View
	Pg. 3	Removed 30ns and 45ns (Commercial only) speed grade offerings from DC Electrical table
		Revised notes and footnotes
	Pg. 5	Removed 30ns speed grade offering from AC Electrical table
		Revised notes and footnotes
	Pg. 6	Expressed Military Temperature range on AC Electrical table
		Revised notes and footnotes
	Pg. 8	Removed Note 1 and renumbered notes and footnotes
	Pg. 9	Revised Ordering Information and presented by temperature range offering
	Pg. 10	Added Datasheet Document History
08/09/00:		Not recommended for new designs
02/01/01:		Remove "Not recommended for new designs"
11/15/06:	Pg. 3	Changed power limits for commercial and industrial. Refer to PCNSR-0602-03. Added Restricted hazardous substance device to ordering information.
11/01/08:	Pg. 2,9	Corrected typo on pin 21 in 32-Pin LCC diagram. Updated the ordering information by removing the "IDT" notation.
04/28/11:	Pg. 1, 2, 5, 9	Added 20ns to Industrial offering. Obsoleted 28-pin 600 mil, 32-pin LCC and Added Tape and Reel to Ordering information and updated description of Restricted hazardous substance device to Green.
09/26/13:	Pg. 1	In the Description: removed IDT's reference to fabrication and removed the sentence "In the full standby mode, the low-power device consumes less than 15μ W, typically".



**CORPORATE HEADQUARTERS**  
 6024 Silver Creek Valley Road  
 San Jose, CA 95138

**for SALES:**  
 800-345-7015 or  
 408-284-8200  
 fax: 408-284-2775  
[www.idt.com](http://www.idt.com)

**for Tech Support:**  
[sramhelp@idt.com](mailto:sramhelp@idt.com)  
 408-284-4532

The IDT logo is a registered trademark of Integrated Device Technology, Inc.