

Sensorless Motor Control IC for Appliances

Features

- **MCE™ (Motion Control Engine) - Hardware based computation engine for high efficiency sinusoidal sensorless control of permanent magnet AC motor**
- **Support Induction motor sensorless FOC control**
- **Supports both interior and surface permanent magnet motors**
- **Built-in hardware peripheral for single shunt current feedback reconstruction**
- **No external current or voltage sensing operational amplifier required**
- **Three/two-phase Space Vector PWM**
- **Analog output (PWM)**
- **Embedded 8-bit high speed microcontroller (8051) for flexible I/O and man-machine control**
- **JTAG programming port for emulation/debugger**
- **Serial communication interface (UART)**
- **I²C/SPI serial interface**
- **Watchdog timer with independent analog clock**
- **Three general purpose timers/counters**
- **Two special timers: periodic timer, capture timer**
- **Internal 'One-Time Programmable' (OTP) memory and internal RAM for final production usage**
- **Pin compatible with IRMCF371, RAM version**
- **1.8V/3.3V CMOS**

Product Summary

Maximum crystal frequency	60 MHz
Maximum internal clock (SYSCLK) frequency	128 MHz
Maximum 8051 clock frequency	33 MHz
Sensorless control computation time	11 µsec typ
MCE™ computation data range	16 bit signed
8051 OTP Program memory	64K bytes
MCE program and Data RAM	8K bytes
GateKill latency (digital filtered)	2 µsec
PWM carrier frequency counter	16 bits/ SYSCLK
A/D input channels	4
A/D converter resolution	12 bits
A/D converter conversion speed	2 µsec
8051 instruction execution speed	2 SYSCLK
Analog output (PWM) resolution	8 bits
UART baud rate (typ)	57.6K bps
Number of I/O (max)	13
Package (lead-free)	QFP48
Operating temperature	-40°C ~ 85°C

Description

IRMCK371 is a high performance OTP based motion control IC designed primarily for appliance applications. IRMCK371 is designed to achieve low cost and high performance control solutions for advanced inverterized appliance motor control. IRMCK371 contains two computation engines. One is Motion Control Engine (MCE™) for sensorless control of permanent magnet motors; the other is an 8-bit high-speed microcontroller (8051). Both computation engines are integrated into one monolithic chip. The MCE™ contains a collection of control elements such as Proportional plus Integral, Vector rotator, Angle estimator, Multiply/Divide, Low loss SVPWM, Single Shunt IFB. The user can program a motion control algorithm by connecting these control elements using a graphic compiler. Key components of the sensorless control algorithms, such as the Angle Estimator, are provided as complete pre-defined control blocks implemented in hardware. A unique analog/digital circuit and algorithm to fully support single shunt current reconstruction is also provided. The 8051 microcontroller performs 2-cycle instruction execution (16MIPS at 33MHz). The MCE and 8051 microcontroller are connected via dual port RAM to process signal monitoring and command input. An advanced graphic compiler for the MCE™ is seamlessly integrated into the MATLAB/Simulink environment, while third party JTAG based emulator tools are supported for 8051 developments. IRMCK371 comes with a small QFP48 pin lead-free package..

TABLE OF CONTENTS

1	Overview	5
2	IRMCK371 Block Diagram and Main Functions	6
3	Pinout	8
4	Input/Output of IRMCK371	9
4.1	8051 Peripheral Interface Group	10
4.2	Motion Peripheral Interface Group	10
4.3	Analog Interface Group	11
4.4	Power Interface Group	11
4.5	Test Interface Group	11
5	Application Connections	12
6	DC Characteristics	13
6.1	Absolute Maximum Ratings	13
6.2	System Clock Frequency and Power Consumption	13
6.3	Digital I/O DC Characteristics	14
6.4	PLL and Oscillator DC characteristics	14
6.5	Analog I/O DC Characteristics	15
6.6	Under Voltage Lockout DC characteristics	15
6.7	AREF Characteristics	15
7	AC Characteristics	16
7.1	PLL AC Characteristics	16
7.2	Analog to Digital Converter AC Characteristics	17
7.3	Op Amp AC Characteristics	17
7.4	SYNC to SVPWM and A/D Conversion AC Timing	18
7.5	GATEKILL to SVPWM AC Timing	19
7.6	Interrupt AC Timing	19
7.7	I ² C AC Timing	20
7.8	SPI AC Timing	21
7.8.1	SPI Write AC timing	21
7.8.2	SPI Read AC Timing	22
7.9	UART AC Timing	23
7.10	CAPTURE Input AC Timing	24
7.11	JTAG AC Timing	25
7.12	OTP Programming Timing	26
8	I/O Structure	27
9	Pin List	30
10	Package Dimensions	32
11	Part Marking Information	33
12	Order Information	33

TABLE OF FIGURES

Figure 1. Typical Application Block Diagram Using IRMCK371.....	5
Figure 2. IRMCK371 Internal Block Diagram.....	6
Figure 3. IRMCK371 Pin Configuration.....	8
Figure 4. Input/Output of IRMCK371	9
Figure 5. Application Connection of IRMCK371	12
Figure 6. Clock Frequency vs. Power Consumption.....	13
Figure 7. Crystal oscillator circuit.....	16
Figure 8. Voltage droop of sample and hold.....	17
Figure 9. SYNC to SVPWM and A/D Conversion AC Timing	18
Figure 10. GATEKILL to SVPWM AC Timing	19
Figure 11. Interrupt AC Timing	19
Figure 12. I ² C AC Timing	20
Figure 13. SPI write AC Timing.....	21
Figure 14. SPI read AC Timing.....	22
Figure 15. UART AC Timing	23
Figure 16. CAPTURE Input AC Timing.....	24
Figure 17. JTAG AC Timing.....	25
Figure 18. OTP Programming Timing.....	26
Figure 19. All digital I/O except motor PWM output.....	27
Figure 20. RESET, GATEKILL I/O	27
Figure 21. Analog input	28
Figure 22. Analog operational amplifier output and AREF I/O structure.....	28
Figure 23. VPP programming pin I/O structure	28
Figure 24. VSS, AVSS and PLLVSS pin structure	29
Figure 25. VDD1, VDD2, AVDD and PLLVDD pin structure	29
Figure 26. XTAL0/XTAL1 pins structure	29

TABLE OF TABLES

Table 1.	Absolute Maximum Ratings	13
Table 2.	System Clock Frequency	13
Table 3.	Digital I/O DC Characteristics	14
Table 4.	PLL DC Characteristics	14
Table 5.	Analog I/O DC Characteristics	15
Table 6.	UVcc DC Characteristics	15
Table 7.	AREF DC Characteristics	15
Table 8.	PLL AC Characteristics.....	16
Table 9.	A/D Converter AC Characteristics	17
Table 10.	Current Sensing OP amp Amp AC Characteristics.....	17
Table 11.	SYNC AC Characteristics	18
Table 12.	GATEKILL to SVPWM AC Timing	19
Table 13.	Interrupt AC Timing.....	19
Table 14.	I ² C AC Timing	20
Table 15.	SPI Write AC Timing	21
Table 16.	SPI Read AC Timing.....	22
Table 17.	UART AC Timing	23
Table 18.	CAPTURE AC Timing	24
Table 19.	JTAG AC Timing	25
Table 20.	OTP Programming Timing	26
Table 21.	Pin List	31

1 Overview

IRMCK371 is a new International Rectifier integrated circuit device primarily designed as a one-chip solution for complete inverter controlled appliance motor control applications. Unlike a traditional microcontroller or DSP, the IRMCK371 provides a built-in closed loop sensorless control algorithm using the unique Motion Control Engine (MCE™) for permanent magnet motors. The MCE™ consists of a collection of control elements, motion peripherals, a dedicated motion control sequencer and dual port RAM to map internal signal nodes. IRMCK371 also employs a unique single shunt current reconstruction circuit to eliminate additional analog/digital circuitry and enables a direct shunt resistor interface to the IC. Motion control programming is achieved using a dedicated graphical compiler integrated into the MATLAB/Simulink™ development environment. Sequencing, user interface, host communication, and upper layer control tasks can be implemented in the 8051 high-speed 8-bit microcontroller. The 8051 microcontroller is equipped with a JTAG port to facilitate emulation and debugging tools. Figure 1 shows a typical application schematic using the IRMCK371.

IRMCF371 is intended for development purpose and contains 48K bytes of RAM, which can be loaded from external EEPROM for 8051 program execution. For high volume production, IRMCK371 contains OTP ROM in place of program RAM to reduce the cost. Both IRMCK371 and IRMCK371 come in the same 48-pin QFP package with identical pin configuration to facilitate PC board layout and transition to mass production

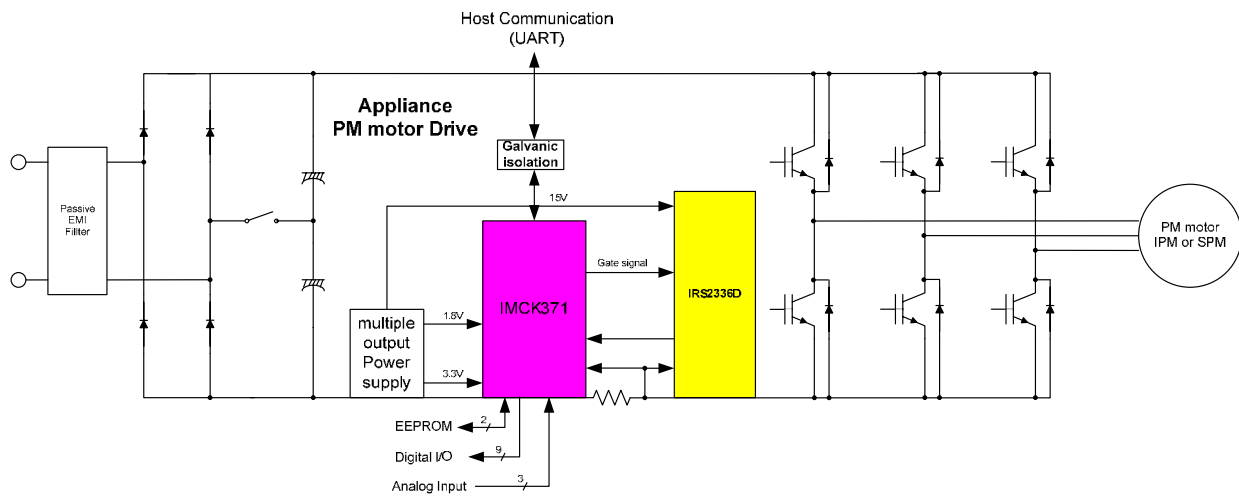

Figure 1. Typical Application Block Diagram Using IRMCK371

2 IRMCK371 Block Diagram and Main Functions

IRMCK371 block diagram is shown in Figure 2.

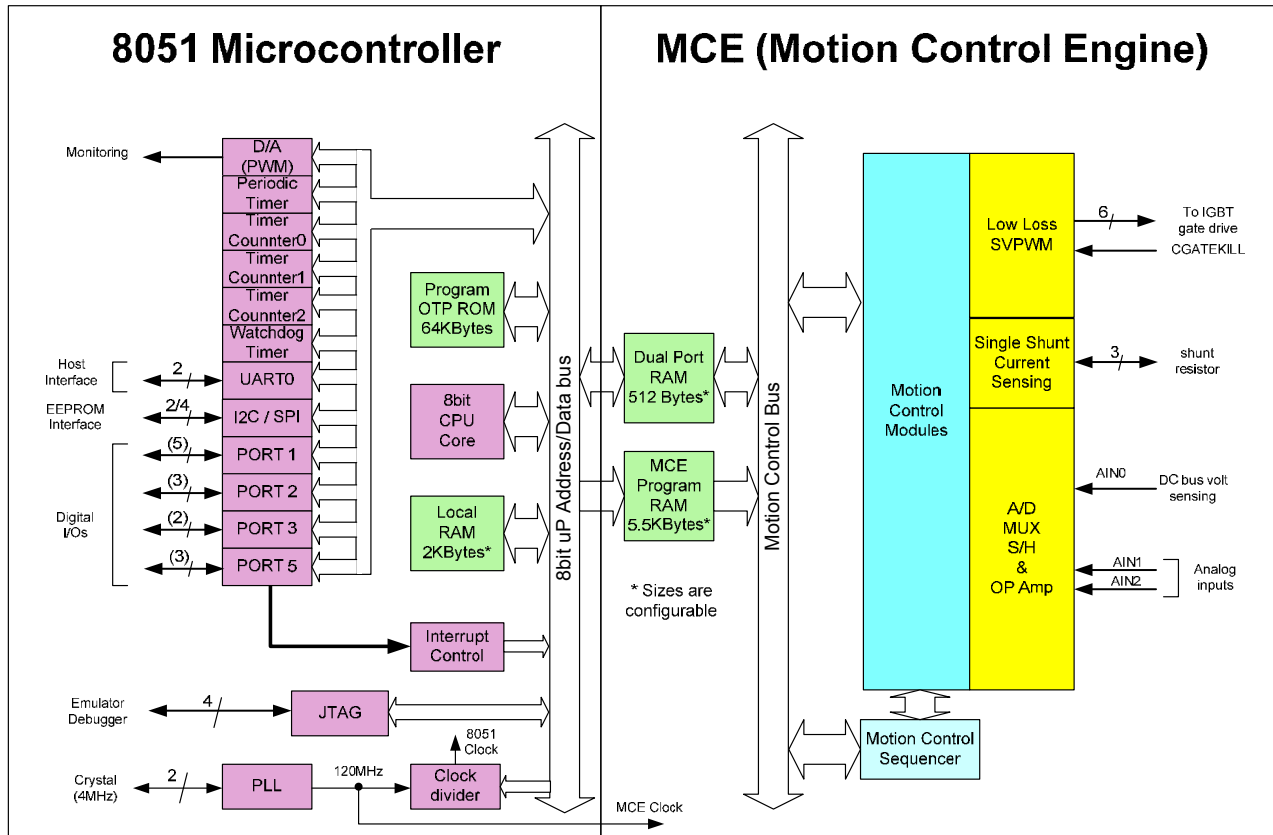

Figure 2. IRMCK371 Internal Block Diagram

IRMCK371 contains the following functions for sensorless AC motor control applications:

- Motion Control Engine (MCE™)
 - Proportional plus Integral block
 - Low pass filter
 - Differentiator and lag (high pass filter)
 - Ramp
 - Limit
 - Angle estimate (sensorless control)
 - Inverse Clark transformation
 - Vector rotator
 - Bit latch
 - Peak detect
 - Transition
 - Multiply-divide (signed and unsigned)

- Divide (signed and unsigned)
- Adder
- Subtractor
- Comparator
- Counter
- Accumulator
- Switch
- Shift
- ATAN (arc tangent)
- Function block (any curve fitting, nonlinear function)
- 16-bit wide Logic operations (AND, OR, XOR, NOT, NEGATE)
- MCE™ program and data memory (6K byte).^{Note 1}
- MCE™ control sequencer

- 8051 microcontroller
 - Three 16-bit timer/counters
 - 16-bit periodic timer
 - 16-bit analog watchdog timer
 - 16-bit capture timer
 - Up to 13 discrete I/Os
 - Four-channel 12-bit A/D
 - One buffered channel for current sensing (0 – 1.2V input)
 - Three unbuffered channels (0 – 1.2V input)
 - JTAG port (4 pins)
 - One channel of analog output (8-bit PWM)
 - UART
 - I²C/SPI port
 - 64K byte program OTP
 - 2K byte data RAM.^{Note 1}

Note 1: Total size of RAM is 8K byte including MCE program, MCE data, and 8051 data. Different sizes can be allocated depending on applications.

3 Pinout

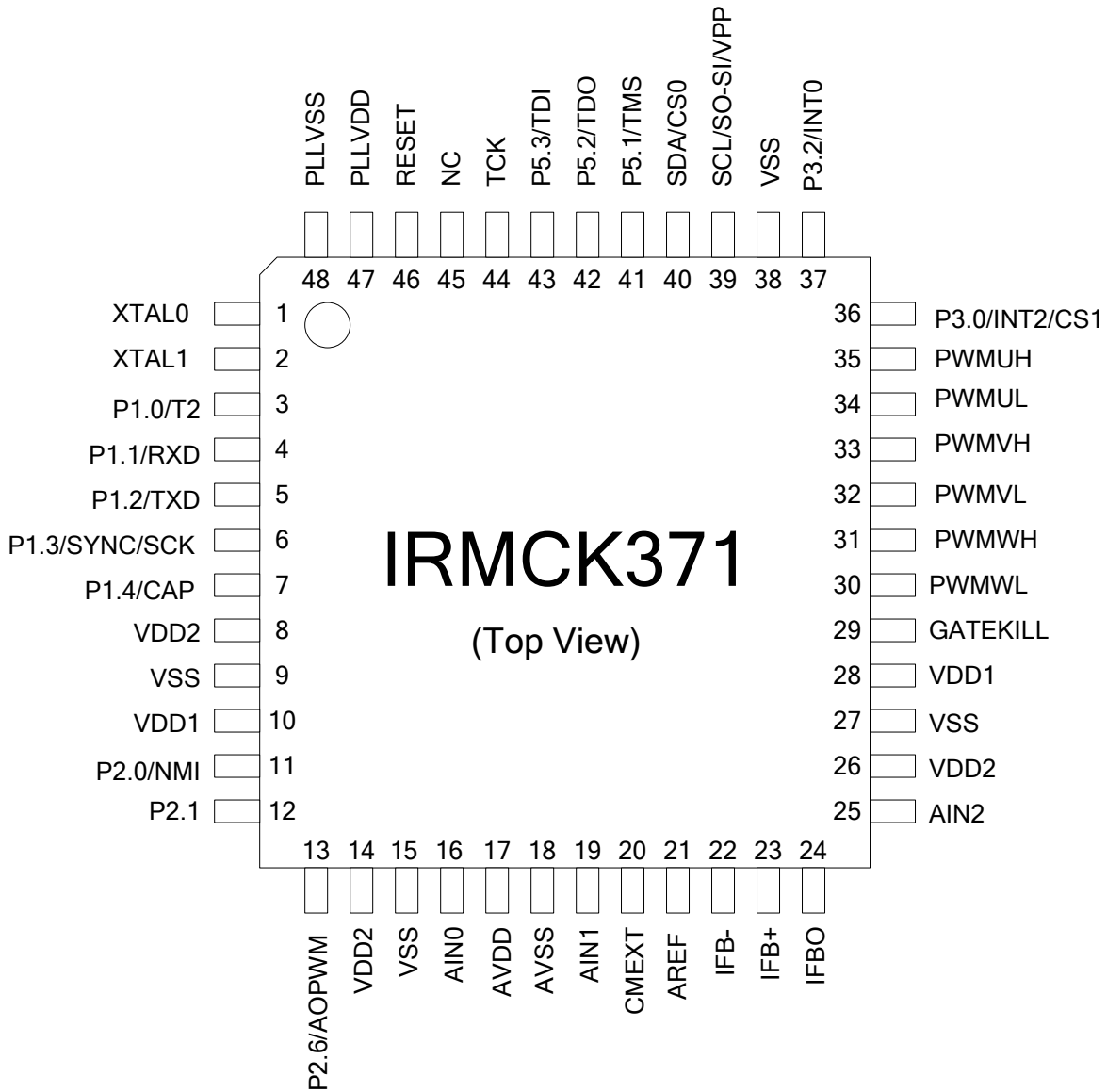

Figure 3. IRMCK371 Pin Configuration

4 Input/Output of IRMCK371

All I/O signals of IRMCK371 are shown in Figure 4. All I/O pins are 3.3V logic interface except A/D interface pins.

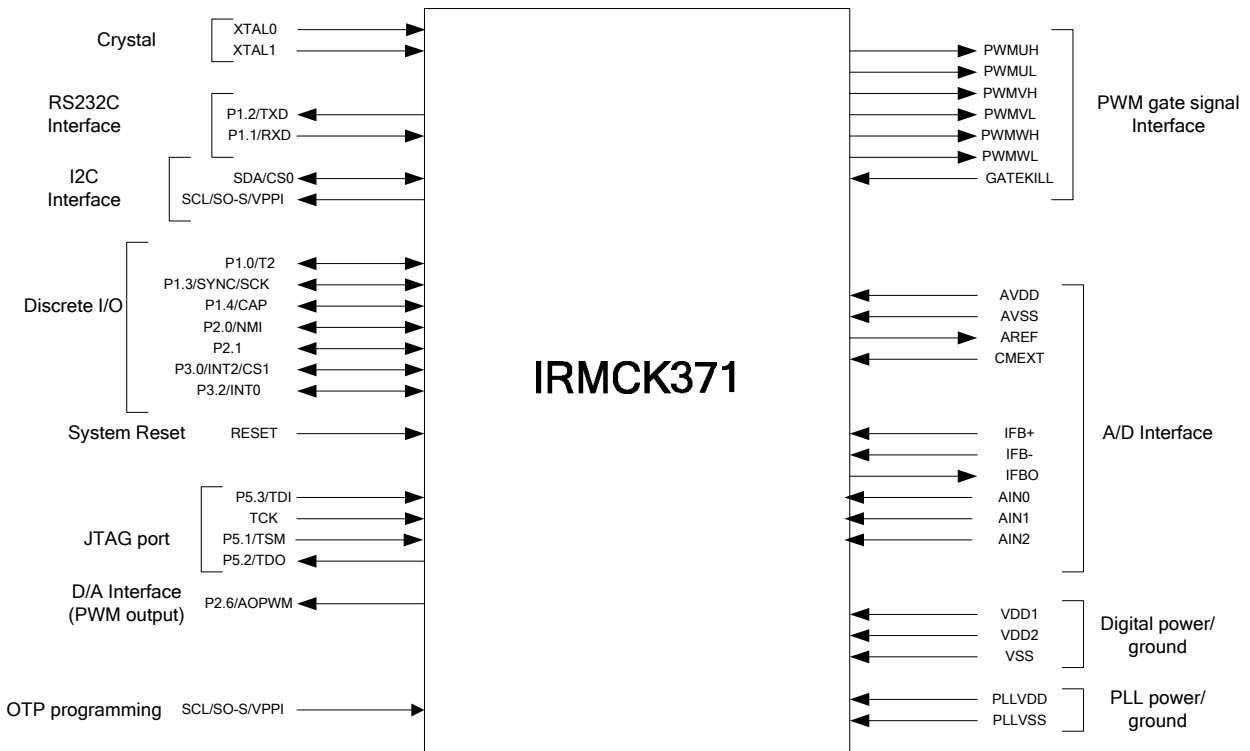

Figure 4. Input/Output of IRMCK371

4.1 8051 Peripheral Interface Group

UART Interface

P1.2/TXD	Output, Transmit data from IRMCK371, can be configured as P1.2
P1.1/RXD	Input, Receive data to IRMCK371, can be configured as P1.1

Discrete I/O Interface

P1.0/T2	Input/output port 1.0, can be configured as Timer 2 input
P1.1/RXD	Input/output port 1.1, can be configured as RXD input
P1.2/TXD	Input/output port 1.2, can be configured as TXD output
P1.3/SYNC/SCK	Input/output port 1.3, can be configured as SYNC output or SPI clock
P1.4/CAP	Input/output port 1.4, can be configured as Capture Timer input
P2.0/NMI	Input/output port 2.0, can be configured as non-maskable interrupt input
P2.1	Input/output port 2.1
P3.0/INT2/CS1	Input/output port 3.0, can be configured as INT2 input or SPI chip select 1
P3.2/INT0	Input/output port 3.2, can be configured as INT0 input

Analog Output Interface

AOPWM	Output, PWM output 0, 8-bit resolution, configurable carrier frequency
-------	--

Crystal Interface

XTAL0	Input, connected to crystal
XTAL1	Output, connected to crystal

Reset Interface

RESET	Inout, system reset, needs to be pulled up to VDD1 but doesn't require external RC time constant
-------	--

I²C/SPI Interface

SCL/SO-SI	Input/output, I ² C clock output or SPI data
SDA/CS0	Input/output, I ² C Data line or SPI chip select 0
P3.0/INT2/CS1	Input/output, INT2 or SPI chip select 1
P1.3/SYNC/SCK	Input/output, SYNC output or SPI clock, needs to be pulled up to VDD1 in order to boot from I ² C EEPROM

4.2 Motion Peripheral Interface Group

PWM

PWMUH	Output, PWM phase U high side gate signal
PWMUL	Output, PWM phase U low side gate signal
PWMVH	Output, PWM phase V high side gate signal
PWMVL	Output, PWM phase V low side gate signal
PWMWH	Output, PWM phase W high side gate signal
PWMWL	Output, PWM phase W low side gate signal

Fault

GATEKILL	Input, upon assertion, this negates all six PWM signals, programmable logic sense
----------	---

4.3 Analog Interface Group

AVDD	Analog power (1.8V)
AVSS	Analog power return
AREF	0.6V buffered output
CMEXT	Unbuffered 0.6V, input to the AREF buffer, capacitor needs to be connected.
IFB+	Input, Operational amplifier positive input for shunt resistor current sensing
IFB-	Input, Operational amplifier negative input for shunt resistor current sensing
IFBO	Output, Operational amplifier output for shunt resistor current sensing
AIN0	Input, Analog input channel 0 (0 – 1.2V), typically configured for DC bus voltage input
AIN1	Input, Analog input channel 1 (0 – 1.2V), needs to be pulled down to AVSS if unused
AIN2	Input, Analog input channel 2 (0 – 1.2V), needs to be pulled down to AVSS if unused

4.4 Power Interface Group

VDD1	Digital power for I/O (3.3V)
VDD2	Digital power for core logic (1.8V)
VSS	Digital common
PLLVD	PLL power (1.8V)
PLLSS	PLL ground return

4.5 Test Interface Group

TSTMOD	Must be tied to VSS, used only for factory testing.
P5.1/TSM	Input/output port 5.1, configured as JTAG port by default
P5.2/TDO	Input/output port 5.2, configured as JTAG port by default
P5.3/TDI	Input/output port 5.3, configured as JTAG port by default
TCK	Input, JTAG test clock

5 Application Connections

Typical application connection is shown in Figure 5. All components necessary to implement a complete sensorless drive control algorithm are shown connected to IRMCK371.

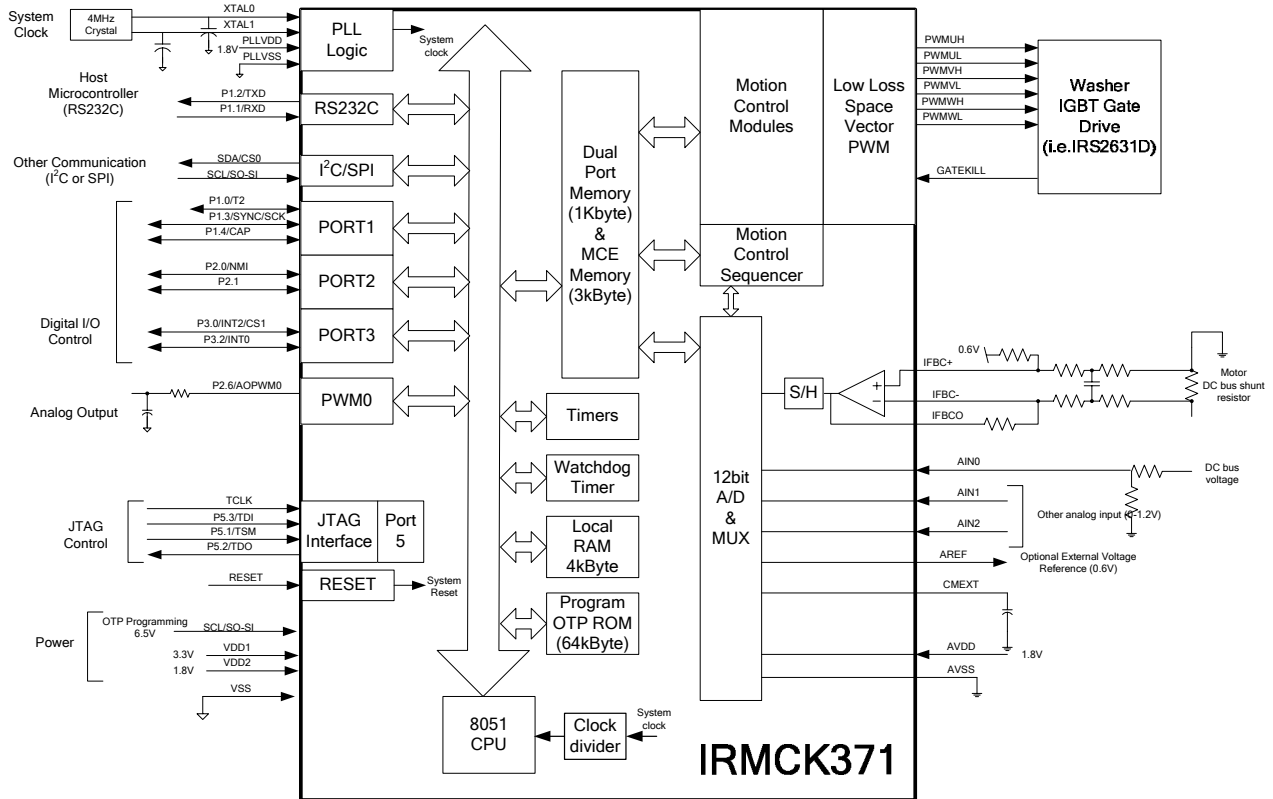

Figure 5. Application Connection of IRMCK371

6 DC Characteristics

6.1 Absolute Maximum Ratings

Symbol	Parameter	Min	Typ	Max	Condition
V _{DD1}	Supply Voltage	-0.3 V	-	3.6 V	Respect to VSS
V _{DD2}	Supply Voltage	-0.3 V	-	1.98 V	Respect to VSS
V _{IA}	Analog Input Voltage	-0.3 V	-	1.98 V	Respect to AVSS
V _{ID}	Digital Input Voltage	-0.3 V	-	3.65 V	Respect to VSS
T _A	Ambient Temperature	-40 °C	-	85 °C	
T _S	Storage Temperature	-65 °C	-	150 °C	

Table 1. Absolute Maximum Ratings

Caution: Stresses beyond those listed in “Absolute Maximum Ratings” may cause permanent damage to the device. These are stress ratings only and function of the device at these or any other conditions beyond those indicated in the operational sections of the specifications are not implied.

6.2 System Clock Frequency and Power Consumption

Symbol	Parameter	Min	Typ	Max	Unit
SYSCLOCK	System Clock	32	-	128	MHz
8051CLK	8051 Clock	-	-	32	MHz

Table 2. System Clock Frequency

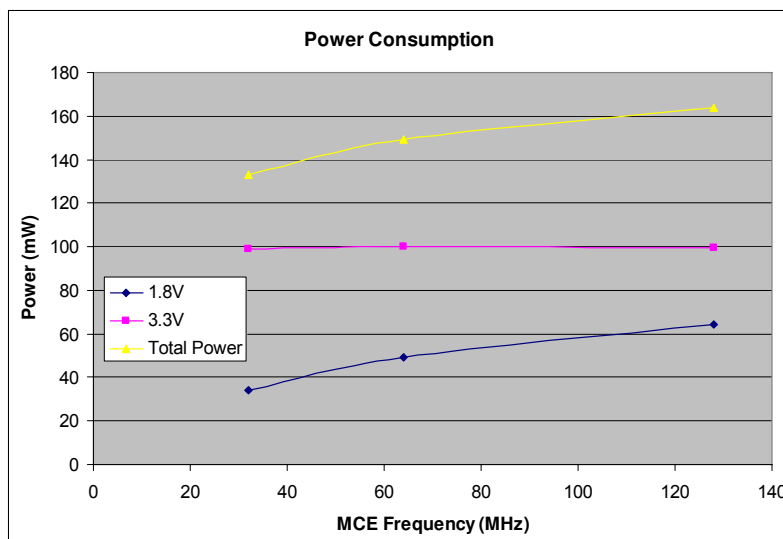

6.3 Digital I/O DC Characteristics

Symbol	Parameter	Min	Typ	Max	Condition
V _{DD1}	Supply Voltage	3.0 V	3.3 V	3.6 V	Recommended
V _{DD2}	Supply Voltage	1.62 V	1.8 V	1.98 V	Recommended
V _{IL}	Input Low Voltage	-0.3 V	-	0.8 V	Recommended
V _{IH}	Input High Voltage	2.0 V		3.6 V	Recommended
C _{IN}	Input capacitance	-	3.6 pF	-	(1)
I _L	Input leakage current		±10 nA	±1 µA	V _O = 3.3 V or 0 V
I _{OL1} ⁽²⁾	Low level output current	8.9 mA	13.2 mA	15.2 mA	V _{OL} = 0.4 V (1)
I _{OH1} ⁽²⁾	High level output current	12.4 mA	24.8 mA	38 mA	V _{OH} = 2.4 V (1)
I _{OL2} ⁽³⁾	Low level output current	17.9 mA	26.3 mA	33.4 mA	V _{OL} = 0.4 V (1)
I _{OH2} ⁽³⁾	High level output current	24.6 mA	49.5 mA	81 mA	V _{OH} = 2.4 V (1)

Table 3. Digital I/O DC Characteristics

Note:

- (1) Data guaranteed by design.
- (2) Applied to SCL/SO-SI, SDA/CS0 pins.
- (3) Applied to P1.0/T2, P1.1/RXD, P1.2/TXD, P1.3/SYNC/SCK, P1.4/CAP, P2.0/NMI, P2.1, P2.6/AOPWM0, P3.0/INT2/CS1, P3.2/INT0, P5.1/TMS, P5.2/TDO, P5.3/TDI, GATEKILL, PWMUL, PWMUH, PWMVL, PWMVH, PWMWL, PWMWH pins.

6.4 PLL and Oscillator DC characteristics

Symbol	Parameter	Min	Typ	Max	Condition
V _{PLLVD}	Supply Voltage	1.62 V	1.8 V	1.92 V	Recommended
V _{IL OSC}	Oscillator Input Low Voltage	V _{PLLSS}	-	0.2* V _{PLLVD}	V _{PLLVD} = 1.8 V (1)
V _{IH OSC}	Oscillator Input High Voltage	0.8* V _{PLLVD}		V _{PLLVD}	V _{PLLVD} = 1.8 V (1)

Table 4. PLL DC Characteristics

Note:

- (1) Data guaranteed by design.

6.5 Analog I/O DC Characteristics

- OP amp for current sensing (IFB+, IFB-, IFBO)

$C_{AREF} = 1nF$, $C_{MEXT} = 100nF$. Unless specified, $T_a = 25^{\circ}C$.

Symbol	Parameter	Min	Typ	Max	Condition
V_{AVDD}	Supply Voltage	1.71 V	1.8 V	1.89 V	Recommended
V_{OFFSET}	Input Offset Voltage	-	-	26 mV	$V_{AVDD} = 1.8 V$
V_I	Input Voltage Range	0 V		1.2 V	Recommended
V_{OUTSW}	OP amp output operating range	50 mV ⁽¹⁾	-	1.2 V	$V_{AVDD} = 1.8 V$
C_{IN}	Input capacitance	-	3.6 pF	-	(1)
R_{FDBK}	OP amp feedback resistor	5 k Ω	-	20 k Ω	Requested between IFBO and IFB-
OP_{GAINCL}	Operating Close loop Gain	80 db	-	-	(1)
CMRR	Common Mode Rejection Ratio	-	80 db	-	(1)
I_{SRC}	Op amp output source current	-	1 mA	-	$V_{OUT} = 0.6 V$ (1)
I_{SNK}	Op amp output sink current	-	100 μA	-	$V_{OUT} = 0.6 V$ (1)

Table 5. Analog I/O DC Characteristics

Note:

(1) Data guaranteed by design.

6.6 Under Voltage Lockout DC characteristics

Unless specified, $T_a = 25^{\circ}C$, $AVDD (1.8V)$

Symbol	Parameter	Min	Typ	Max	Condition
UV_{CC+}	UVcc positive going Threshold ⁽¹⁾	1.53 V	1.66 V	1.71 V	$V_{DD1} = 3.3 V$
UV_{CC-}	UVcc negative going Threshold	1.52 V	1.62 V	1.71 V	$V_{DD1} = 3.3 V$
UV_{CCH}	UVcc Hysteresys	-	40 mV	-	

Table 6. UVcc DC Characteristics

Note:

(1) Data guaranteed by design.

6.7 AREF Characteristics

$C_{AREF} = 1nF$, $C_{MEXT} = 100nF$. Unless specified, $T_a = 25^{\circ}C$.

Symbol	Parameter	Min	Typ	Max	Condition
V_{AREF}	AREF Output Voltage	495 mV	600 mV	700 mV	$V_{AVDD} = 1.8 V$
ΔV_o	Load regulation ($V_{DC} - 0.6$)	-	1 mV	-	(1)
PSRR	Power Supply Rejection Ratio	-	75 db	-	(1)

Table 7. AREF DC Characteristics

Note: (1) Data guaranteed by design.

7 AC Characteristics

7.1 PLL AC Characteristics

Symbol	Parameter	Min	Typ	Max	Condition
F_{CLKIN}	Crystal input frequency	3.2 MHz	4 MHz	60 MHz	⁽¹⁾ (see figure below)
F_{PLL}	Internal clock frequency	32 MHz	50 MHz	128 MHz	⁽¹⁾
F_{LWPW}	Sleep mode output frequency	$F_{CLKIN} \div 256$	-	-	⁽¹⁾
J_S	Short time jitter	-	200 psec	-	⁽¹⁾
D	Duty cycle	-	50 %	-	⁽¹⁾
T_{LOCK}	PLL lock time	-	-	500 μ sec	⁽¹⁾

Table 8. PLL AC Characteristics

Note:

(1) Data guaranteed by design.

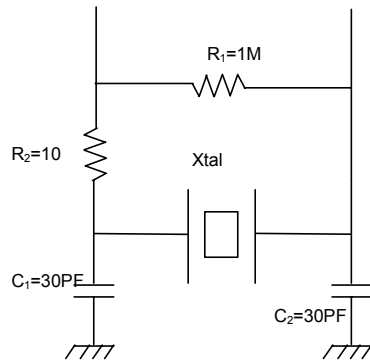

Figure 7 Crystal oscillator circuit

7.2 Analog to Digital Converter AC Characteristics

Unless specified, $T_a = 25^\circ\text{C}$.

Symbol	Parameter	Min	Typ	Max	Condition
T_{CONV}	Conversion time	-	-	2.05 μsec	⁽¹⁾
T_{HOLD}	Sample/Hold maximum hold time	-	-	10 μsec	Voltage droop \leq 15 LSB (see figure below)

Table 9. A/D Converter AC Characteristics

Note:

(1) Data guaranteed by design.

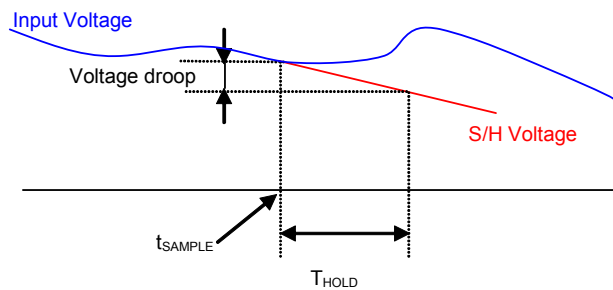

Figure 8 Voltage droop of sample and hold

7.3 Op Amp AC Characteristics

- OP amps for current sensing (IFB+, IFB-, IFBO)

Unless specified, $T_a = 25^\circ\text{C}$.

Symbol	Parameter	Min	Typ	Max	Condition
OP_{SR}	OP amp slew rate	-	10 V/ μsec	-	$V_{\text{AVDD}} = 1.8 \text{ V}$, $CL = 33 \text{ pF}$ ⁽¹⁾
OP_{IMP}	OP input impedance	-	$10^8 \Omega$	-	⁽¹⁾
T_{SET}	Settling time	-	400 ns	-	$V_{\text{AVDD}} = 1.8 \text{ V}$, $CL = 33 \text{ pF}$ ⁽¹⁾

Table 10. Current Sensing OP amp Amp AC Characteristics

Note:

(1) Data guaranteed by design.

7.4 SYNC to SVPWM and A/D Conversion AC Timing

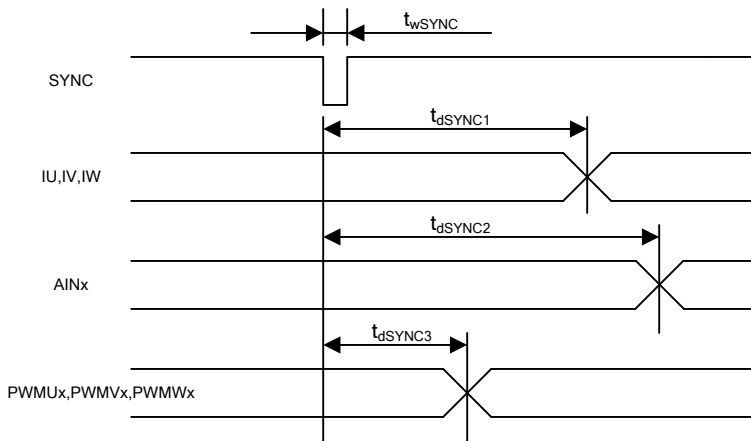

Figure 9 SYNC to SVPWM and A/D Conversion AC Timing

Unless specified, $T_a = 25^\circ\text{C}$.

Symbol	Parameter	Min	Typ	Max	Unit
t_{wSYNC}	SYNC pulse width	-	32	-	SYSClk
t_{dSYNC1}	SYNC to current feedback conversion time	-	-	100	SYSClk
t_{dSYNC2}	SYNC to AIN0-6 analog input conversion time	-	-	200	SYSClk ⁽¹⁾
t_{dSYNC3}	SYNC to PWM output delay time	-	-	2	SYSClk

Table 11. SYNC AC Characteristics

Note:

(1) AIN1 through AIN6 channels are converted once every 6 SYNC events

7.5 GATEKILL to SVPWM AC Timing

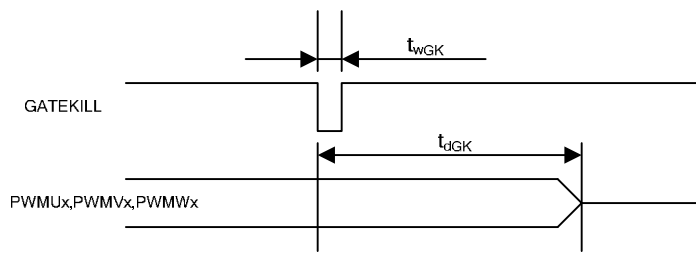

Figure 10 GATEKILL to SVPWM AC Timing

Unless specified, Ta = 25°C.

Symbol	Parameter	Min	Typ	Max	Unit
t _{wGK}	GATEKILL pulse width	32	-	-	SYSClk
t _{dGK}	GATEKILL to PWM output delay	-	-	100	SYSClk

Table 12. GATEKILL to SVPWM AC Timing

7.6 Interrupt AC Timing

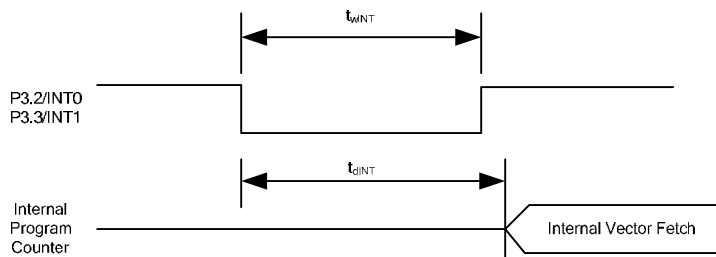

Figure 11 Interrupt AC Timing

Unless specified, Ta = 25°C.

Symbol	Parameter	Min	Typ	Max	Unit
t _{wINT}	INT0, INT1 Interrupt Assertion Time	4	-	-	SYSClk
t _{dINT}	INT0, INT1 latency	-	-	4	SYSClk

Table 13. Interrupt AC Timing

7.7 I²C AC Timing

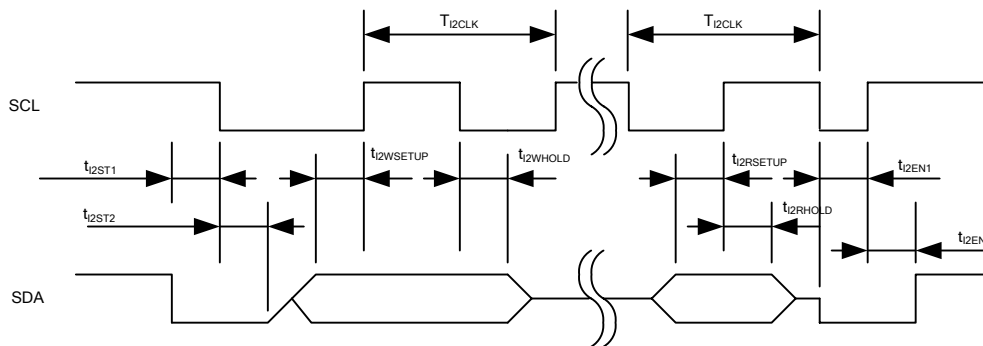

Figure 12 I²C AC Timing

Unless specified, Ta = 25°C.

Symbol	Parameter	Min	Typ	Max	Unit
T _{I2CLK}	I ² C clock period	10	-	8192	SYSCLK
t _{I2ST1}	I ² C SDA start time	0.25	-	-	T _{I2CLK}
t _{I2ST2}	I ² C SCL start time	0.25	-	-	T _{I2CLK}
t _{I2WSETUP}	I ² C write setup time	0.25	-	-	T _{I2CLK}
t _{I2WHOLD}	I ² C write hold time	0.25	-	-	T _{I2CLK}
t _{I2RSETUP}	I ² C read setup time	I ² C filter time ⁽¹⁾	-	-	SYSCLK
t _{I2RHOLD}	I ² C read hold time	1	-	-	SYSCLK

Table 14. I²C AC Timing

Note:

- (1) I²C read setup time is determined by the programmable filter time applied to I²C communication.

7.8 SPI AC Timing

7.8.1 SPI Write AC timing

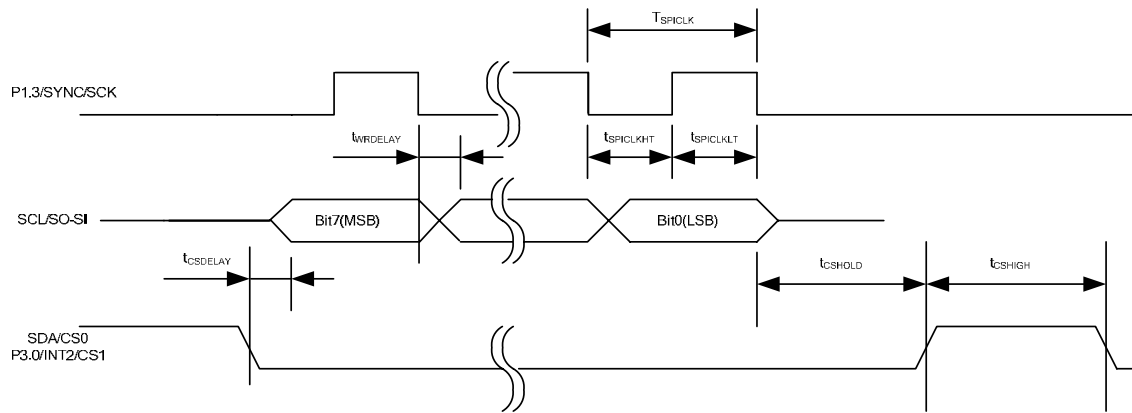

Figure 13 SPI write AC Timing

Unless specified, $T_a = 25^\circ\text{C}$.

Symbol	Parameter	Min	Typ	Max	Unit
T_{SPICLK}	SPI clock period	4	-	-	SYSCLK
t_{SPICLKHT}	SPI clock high time	-	1/2	-	T_{SPICLK}
t_{SPICLKLT}	SPI clock low time	-	1/2	-	T_{SPICLK}
t_{CSDELAY}	CS to data delay time	-	-	10	nsec
t_{WRDELAY}	CLK falling edge to data delay time	-	-	10	nsec
t_{CSHIGH}	CS high time between two consecutive byte transfer	1	-	-	T_{SPICLK}
t_{CSHOLD}	CS hold time	-	1	-	T_{SPICLK}

Table 15. SPI Write AC Timing

7.8.2 SPI Read AC Timing

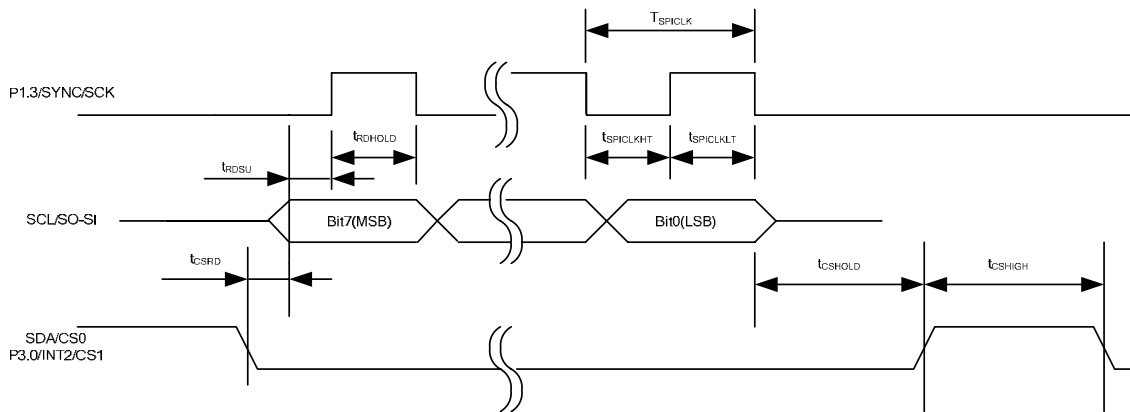

Figure 14 SPI read AC Timing

Unless specified, Ta = 25°C.

Symbol	Parameter	Min	Typ	Max	Unit
T_{SPICLK}	SPI clock period	4	-	-	SYSCLK
$t_{SPICLKHT}$	SPI clock high time	-	1/2	-	T_{SPICLK}
$t_{SPICLKLT}$	SPI clock low time	-	1/2	-	T_{SPICLK}
t_{CSRd}	CS to data delay time	-	-	10	nsec
t_{RDSU}	SPI read data setup time	10	-	-	nsec
t_{RDHOLD}	SPI read data hold time	10	-	-	nsec
t_{CSHIGH}	CS high time between two consecutive byte transfer	1	-	-	T_{SPICLK}
t_{CSHOLD}	CS hold time	-	1	-	T_{SPICLK}

Table 16. SPI Read AC Timing

7.9 UART AC Timing

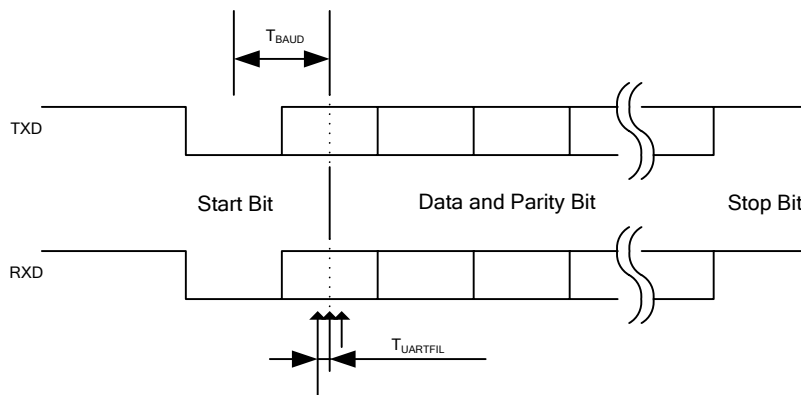

Figure 15 UART AC Timing

Unless specified, $T_a = 25^\circ\text{C}$.

Symbol	Parameter	Min	Typ	Max	Unit
T_{BAUD}	Baud Rate Period	-	57600	-	bit/sec
$T_{UARTFIL}$	UART sampling filter period ⁽¹⁾	-	1/16	-	T_{BAUD}

Table 17. UART AC Timing

Note:

- (1) Each bit including start and stop bit is sampled three times at center of a bit at an interval of $1/16 T_{BAUD}$. If three sampled values do not agree, then UART noise error is generated.

7.10 CAPTURE Input AC Timing

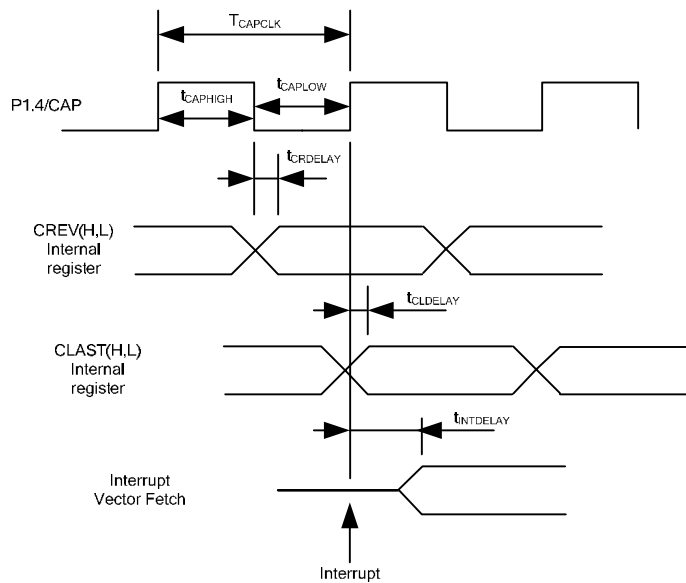

Figure 16 CAPTURE Input AC Timing

Unless specified, $T_a = 25^\circ\text{C}$.

Symbol	Parameter	Min	Typ	Max	Unit
T_{CAPCLK}	CAPTURE input period	8	-	-	SYSCLK
$t_{CAPHIGH}$	CAPTURE input high time	4	-	-	SYSCLK
t_{CAPLOW}	CAPTURE input low time	4	-	-	SYSCLK
$t_{CRDELAY}$	CAPTURE falling edge to capture register latch time	-	-	4	SYSCLK
$t_{CLDELAY}$	CAPTURE rising edge to capture register latch time	-	-	4	SYSCLK
$t_{INTDELAY}$	CAPTURE input interrupt latency time	-	-	4	SYSCLK

Table 18. CAPTURE AC Timing

7.11 JTAG AC Timing

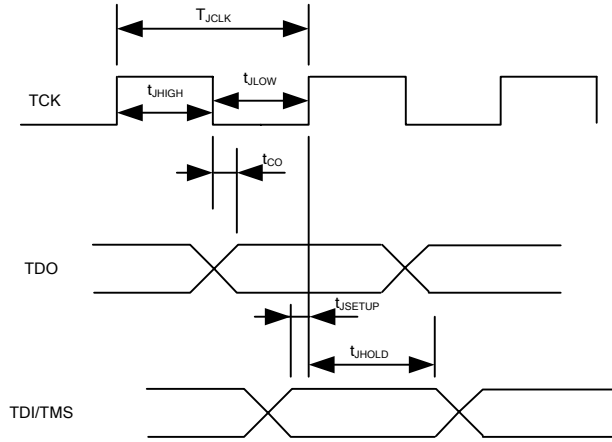

Figure 17 JTAG AC Timing

Unless specified, $T_a = 25^\circ\text{C}$.

Symbol	Parameter	Min	Typ	Max	Unit
T_{JCLK}	TCK Period	-	-	50	MHz
t_{JHIGH}	TCK High Period	10	-	-	nsec
t_{JLOW}	TCK Low Period	10	-	-	nsec
t_{CO}	TCK to TDO propagation delay time	0	-	5	nsec
t_{JSETUP}	TDI/TMS setup time	4	-	-	nsec
t_{JHOLD}	TDI/TMS hold time	0	-	-	nsec

Table 19. JTAG AC Timing

7.12 OTP Programming Timing

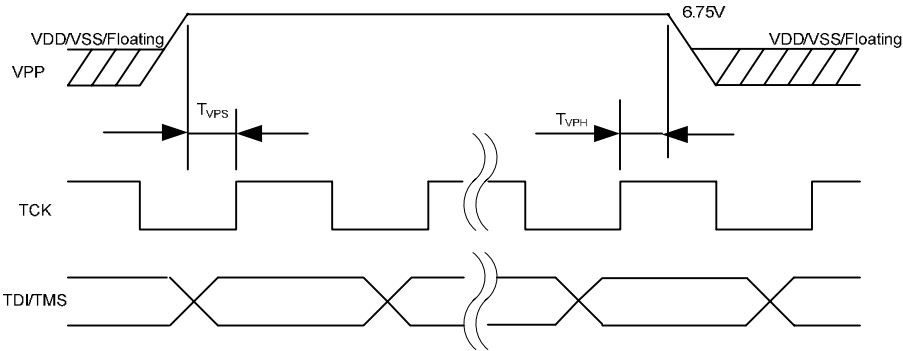

Figure 18 OTP Programming Timing

Unless specified, $T_a = 25^\circ\text{C}$.

Symbol	Parameter	Min	Typ	Max	Unit
T_{VPS}	VPP Setup Time	10	-	-	nsec
T_{VPH}	VPP Hold Time	15	-	-	nsec

Table 20. OTP Programming Timing

8 I/O Structure

The following figure shows the motor PWM and digital I/O structure

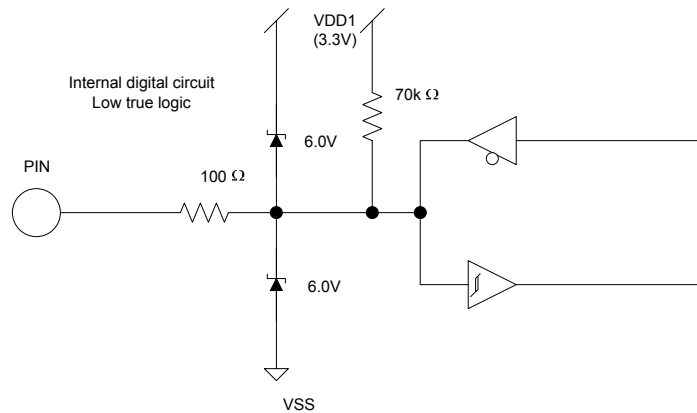

Figure 19 All digital I/O except motor PWM output

The following figure shows RESET and GATEKILL I/O structure.

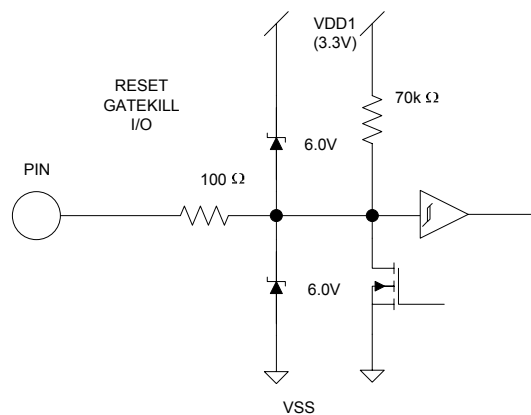

Figure 20 RESET, GATEKILL I/O

The following figure shows the analog input structure.

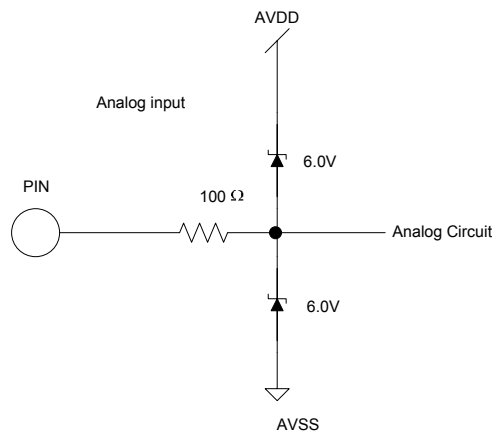

Figure 21 Analog input

The following figure shows all analog operational amplifier output pins and AREF pin I/O structure.

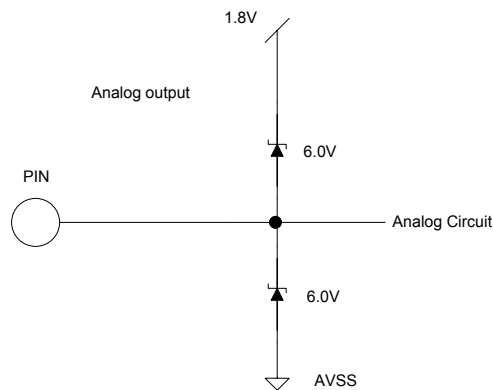

Figure 22 Analog operational amplifier output and AREF I/O structure

The following figure shows the VPP pin I/O structure

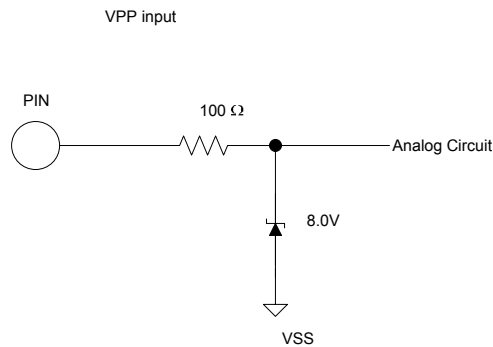

Figure 23 VPP programming pin I/O structure

The following figure shows the VSS, AVSS and PLLVSS pin structure

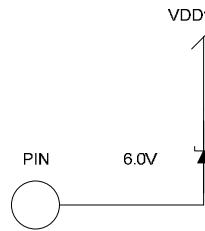

Figure 24 VSS, AVSS and PLLVSS pin structure

The following figure shows the VDD1, VDD2, AVDD and PLLVDD pin structure

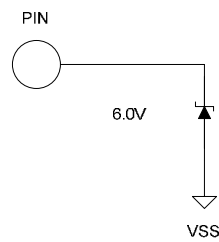

Figure 25 VDD1, VDD2, AVDD and PLLVDD pin structure

The following figure shows the XTAL0 and XTAL1 pins structure

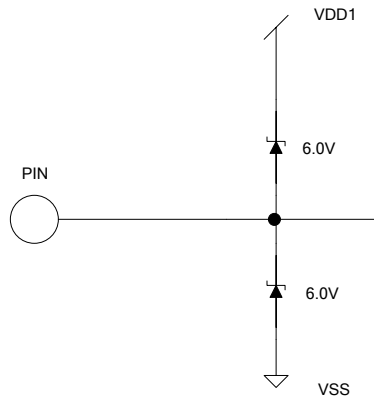

Figure 26 XTAL0/XTAL1 pins structure

9 Pin List

Pin Number	Pin Name	Internal Pull-up /Pull-down	Pin Type	Description
1	XTAL0		I	Crystal input
2	XTAL1		O	Crystal output
3	P1.0/T2		I/O	Discrete programmable I/O or Timer/Counter 2 input
4	P1.1/RXD		I/O	Discrete programmable I/O or UART receive input
5	P1.2/TXD		I/O	Discrete programmable I/O or UART transmit output
6	P1.3/SYNC/SCK		I/O	Discrete programmable I/O or SYNC output or SPI clock output
7	P1.4/CAP		I/O	Discrete programmable I/O or Capture Timer input
8	VDD2		P	1.8V digital power
9	VSS		P	Digital common
10	VDD1		P	3.3V digital power
11	P2.0/NMI		I/O	Discrete I/O or Non Maskable Interrupt
12	P2.1		I/O	Discrete I/O
13	P2.6/AOPWM		I/O	Discrete I/O or PWM digital output
14	VDD2		P	1.8V digital power
15	VSS		P	Digital common
16	AIN0		I	Analog input channel 0, 0-1.2V range, needs to be pulled down to AVSS if unused
17	AVDD		P	1.8V analog power
18	AVSS		P	Analog common
19	AIN1		I	Analog input channel 1, 0-1.2V range, needs to be pulled down to AVSS if unused
20	CMEXT		O	Unbuffered 0.6V output. Capacitor needs to be connected.
21	AREF		O	Analog reference voltage output (0.6V)
22	IFB-		I	Single shunt current sensing OP amp input (-)
23	IFB+		I	Single shunt current sensing OP amp input (+)
24	IFBO		O	Single shunt current sensing OP amp output
25	AIN2		I	Analog input channel 2, 0-1.2V range, needs to be pulled down to AVSS if unused
26	VDD2		P	1.8V digital power
27	VSS		P	Digital common
28	VDD1		P	3.3V digital power
29	GATEKILL		I	PWM shutdown input, 2- μ sec digital filter, configurable either high or low true.
30	PWMWL	70 k Ω Pull up	O	PWM gate drive for phase W low side, configurable either high or low true
31	PWMWH	70 k Ω Pull up	O	PWM gate drive for phase W high side, configurable either high or low true

Pin Number	Pin Name	Internal Pull-up /Pull-down	Pin Type	Description
32	PWMVL	70 kΩ Pull up	O	PWM gate drive for phase V low side, configurable either high or low true
33	PWMVH	70 kΩ Pull up	O	PWM gate drive for phase V high side, configurable either high or low true
34	PWMUL	70 kΩ Pull up	O	PWM gate drive for phase U low side, configurable either high or low true
35	PWMUH	70 kΩ Pull up	O	PWM gate drive for phase U high side, configurable either high or low true
36	P3.0/INT2/CS1		I/O	Discrete programmable I/O or external interrupt 2 input or SPI chip select 1
37	P3.2/NINT0		I/O	Discrete programmable I/O or external interrupt 0 input
38	VSS		P	Digital common
39	SCL/SO-SI		I/O	I2C clock or SPI data
40	SDA/CS0		I/O	I2C data or SPI chip select 0
41	P5.1/TMS		I/O	Discrete I/O or JTAG test mode select
42	P5.2/TDO		I/O	Discrete I/O or JTAG test data output
43	P5.3/TDI		I/O	Discrete I/O or JTAG test data input
44	TCK		I	JTAG test clock input
45	TSTMOD	58 kΩ pull down	I	Test mode input, must be tied to VSS
46	RESET		I/O	Reset, low true, Schmitt trigger input
47	PLLVD		P	1.8V PLL power
48	PLLVS		P	PLL ground

Table 21. Pin List

10 Package Dimensions

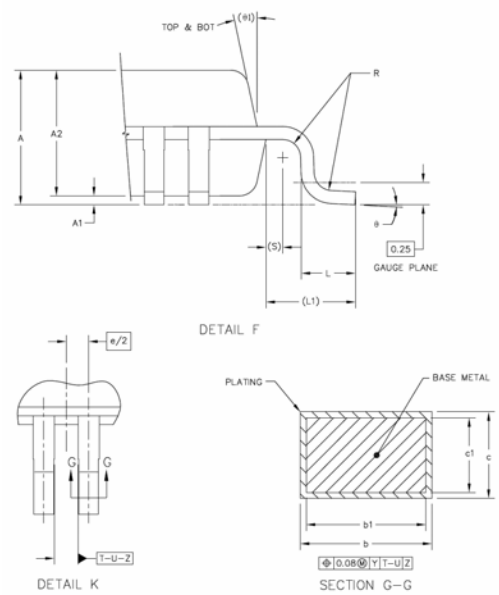
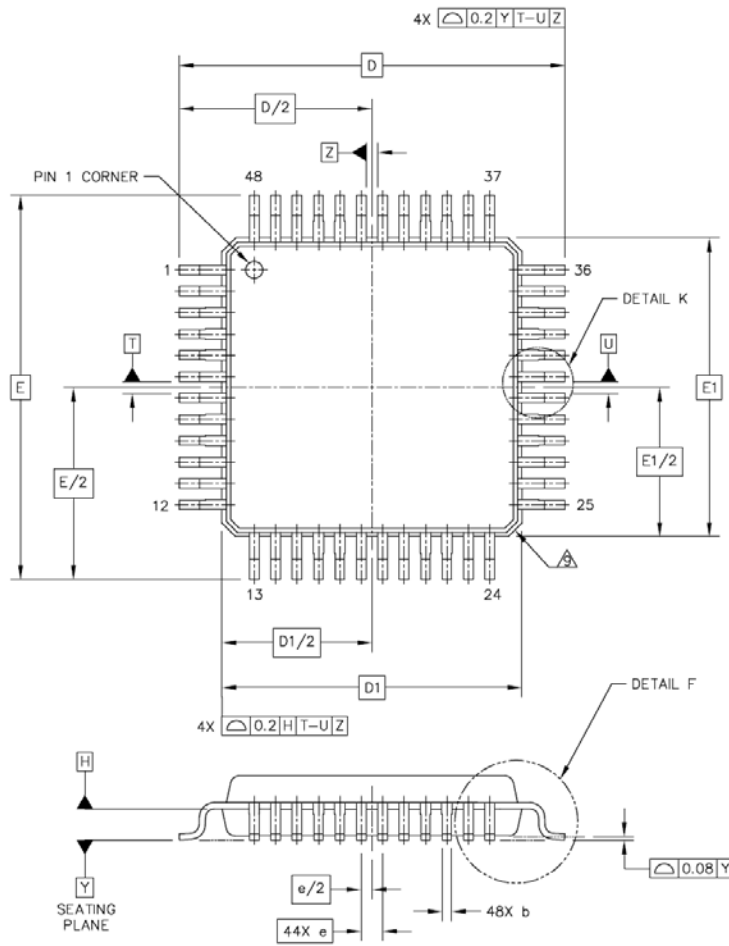

NOTES:

1. DIMENSIONS ARE IN MILLIMETERS.
 2. INTERPRET DIMENSIONS AND TOLERANCES PER ASME Y14.5M-1994.
 3. DATUM PLANE H IS LOCATED AT BOTTOM OF LEAD AND IS COINCIDENT WITH THE LEAD WHERE THE LEAD EXITS THE PLASTIC BODY AT THE BOTTOM OF THE PARTING LINE.
 4. DATUM T, U AND Z TO BE DETERMINED AT DATUM PLANE H.
 5. DIMENSIONS D AND E TO BE DETERMINED AT SEATING PLANE Y.
 6. DIMENSIONS D1 AND E1 DO NOT INCLUDE MOLD PROTRUSION. ALLOWABLE PROTRUSION IS 0.25 PER SIDE. DIMENSIONS D1 AND E1 DO INCLUDE MOLD MISMATCH AND ARE DETERMINED AT DATUM PLANE H.
 7. DIMENSION b DOES NOT INCLUDE DAM BAR PROTRUSION. DAM BAR PROTRUSION SHALL NOT CAUSE THE b DIMENSION TO EXCEED 0.35.
 8. MINIMUM SOLDER PLATE THICKNESS SHALL BE 0.0076.
- △ EXACT SHAPE OF EACH CORNER IS OPTIONAL.

DIM	MIN	MAX	DIM	MIN	MAX	DIM	MIN	MAX
A	1.4	1.6	L1	1 REF				
A1	0.05	0.15	R	0.15	0.25			
A2	1.35	1.45	S	0.2 REF				
b	0.17	0.27	θ	1°	5°			
b1	0.17	0.23	θ1	12° REF				
c	0.09	0.2						
c1	0.09	0.16						
D		9 BSC						
D1		7 BSC						
e		0.5 BSC						
E		9 BSC						
E1		7 BSC						
L	0.5	0.7						

11 Part Marking Information

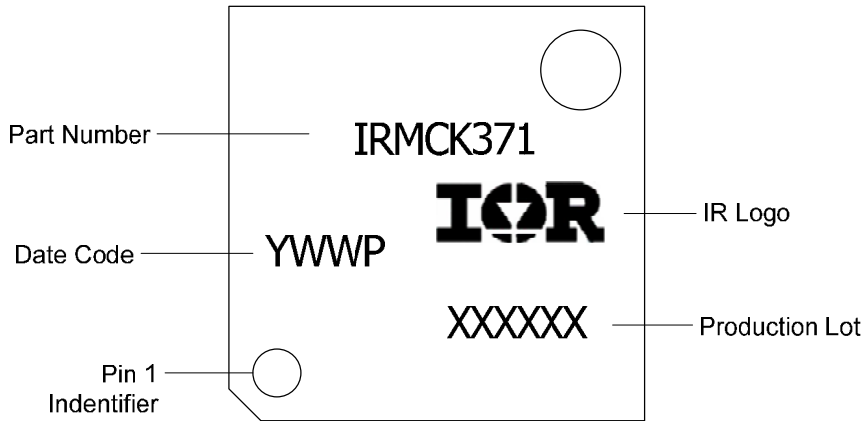

12 Order Information

Lead-Free Part in 48-lead QFP
Moisture Sensitivity Rating – MSL3

Part number	Order quantities
IRMCK371TR	2000 parts on tape and reel in dry pack
IRMCK371TY	2500 parts on trays (160 parts per tray) in dry pack

International
IOR Rectifier

The LQFP-48 is MSL3 qualified
 This product has been designed and qualified for the industrial level
 Qualification standards can be found at www.irf.com <<http://www.irf.com>>
 IR WORLD HEADQUARTERS: 233 Kansas St., El Segundo, California 90245, Tel: (310) 252-7105
 Data and specifications subject to change without notice. 12/25/2007

www.irf.com