

# SPECIFICATIONS

PARAMETERS	VALUES	UNIT
RATED VOLTAGE	3.6	Vpk
OPERATING VOLTAGE RANGE	3 ~ 5	Vpk
RATED CURRENT (MAX)	80	mA
COIL RESISTANCE	20 ± 3	OHM
MINIMUM SPL @ 5 CM	95	dB
RESONANT FREQUENCY	3,100 ± 500	Hz
OPERATING TEMPERATURE	-30 ~ +70	°C
STORAGE TEMPERATURE	-40 ~ +85	°C
HOUSING MATERIAL	LCP	-
TERMINAL MATERIAL	Au PLATED BRASS	-
WEIGHT	0.8	grams

THIS DOCUMENT CONTAINS DATA PROPRIETARY TO PROJECTS UNLIMITED, INC. ANY USE OR REPRODUCTION, IN ANY FORM, WITHOUT PRIOR WRITTEN PERMISSION OF PROJECTS UNLIMITED, INC. IS PROHIBITED.  
©2003, Projects Unlimited Inc.

# REVISION HISTORY

LTR	DESCRIPTION	DATE	APPROVED
-	RELEASED FROM ENGINEERING	2014/07/31	

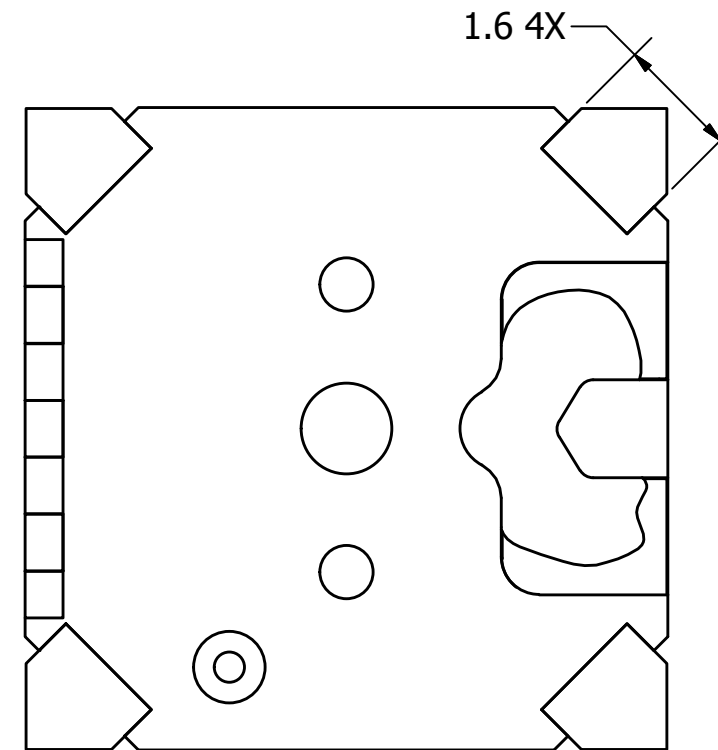
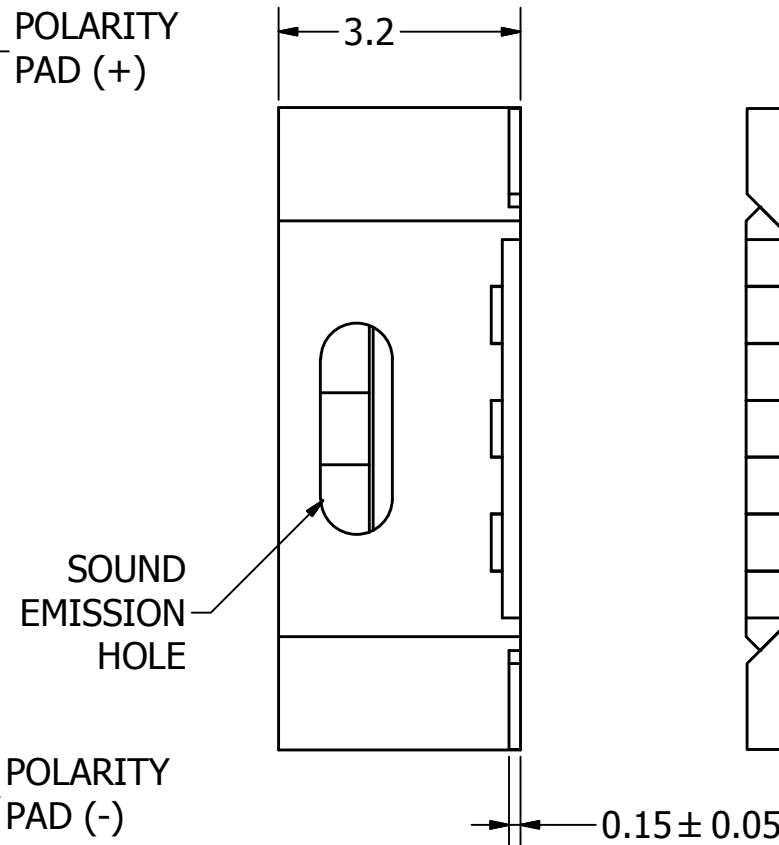
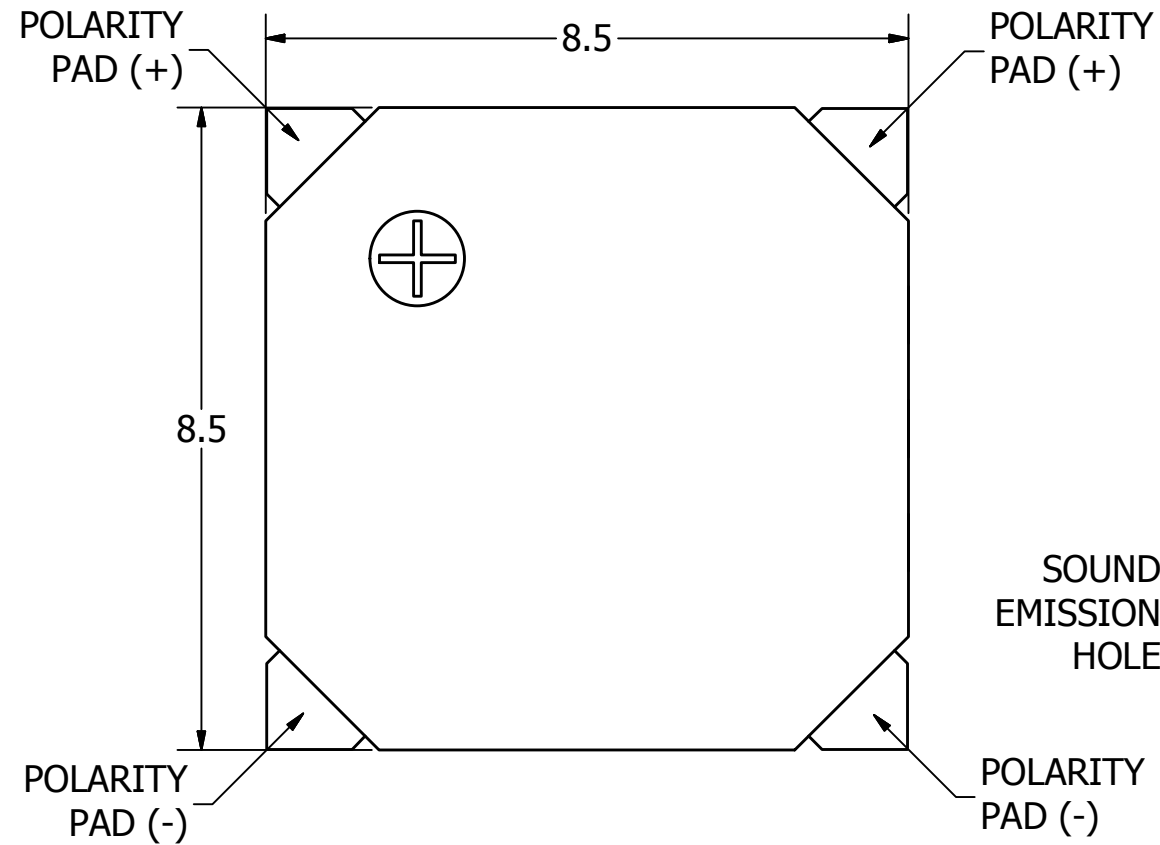
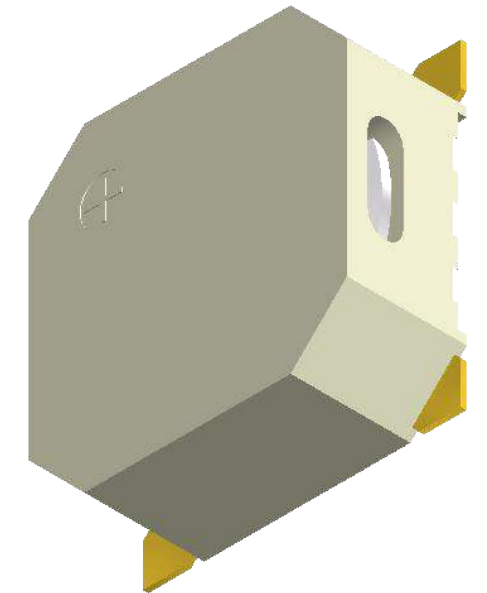

## NOTES:

1. ALL DIMENSIONS ARE IN MILLIMETERS.
2. SPECIFICATIONS SUBJECT TO CHANGE OR WITHDRAWL WITHOUT NOTICE.
3. THIS PART IS RoHS 2011/65/EU COMPLIANT.

UNLESS OTHERWISE SPECIFIED:  
ALL PURCHASES ARE SUBJECT TO AND INCORPORATE THE PUI AUDIO TERMS AND CONDITIONS SALE FOUND AT [http://www.puiaudio.com/pdf/terms\\_conditions.pdf](http://www.puiaudio.com/pdf/terms_conditions.pdf) (paper copy available upon request).  
DIMENSIONS ARE IN MILLIMETERS, TOLERANCES ARE ±0.5 AND ANGLES ARE ±3°.

SIZE  
**A3**

Designed by	Date	Checked by	Date	Approved by	Date	Drawn Date
J.D.	7/31/2014	C.W.	7/31/2014	B.R.	7/31/2014	7/31/2014



**SMT-0931-S-R**

Transducer (Electro-Mech)	Edition	Sheet
	-	1 / 1

SMT-0931-S-R.idw