

DRAWING MADE IN THIRD ANGLE PROJECTION

THIS DRAWING IS UNPUBLISHED. RELEASED FOR PUBLICATION, 19
 © COPYRIGHT 1972 BY AMP INCORPORATED, HARRISBURG, PA. ALL INTERNATIONAL RIGHTS RESERVED. AMP PRODUCTS MAY BE COVERED BY U.S. AND FOREIGN PATENTS AND/OR PATENTS PENDING.

LOC	DIST	P	F	REVISIONS				
				ZONE	LTR	DESCRIPTION	DATE	APPROVED
AF	50				R	REVISED AF-6298	10/19/89	JR/CM

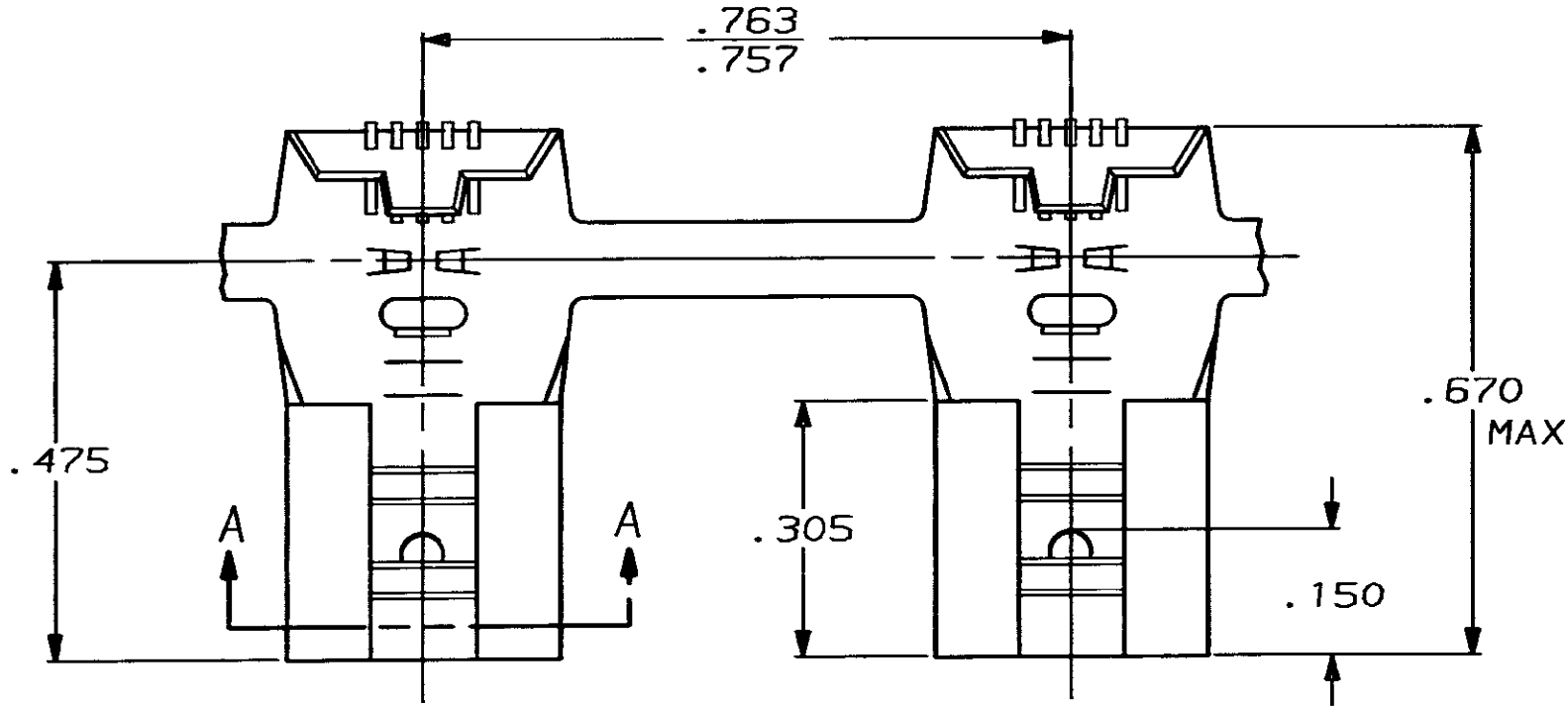

1- CONTINUOUS STRIP ON REELS.

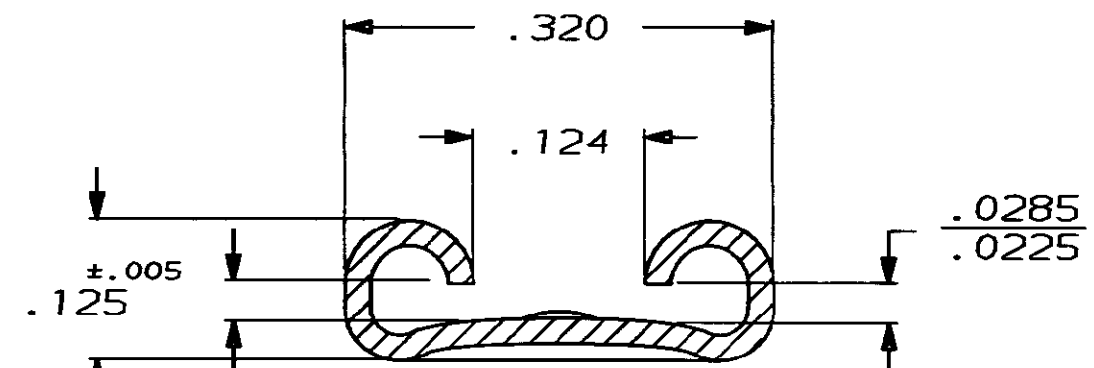

FITS .250 SERIES FASTON TAB
 SECTION A-A

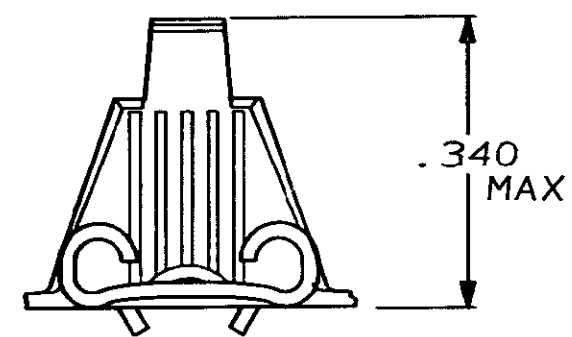

LEFT HAND	18-12	.032 ±.001	TIN	.018 PHOS. BRONZE	62056-7
RIGHT HAND	18-12	.032 ±.001	TIN	.018 PHOS. BRONZE	62056-6
LEFT HAND	18-12	.032 ±.001	---	.018 BRASS	62056-5
LEFT HAND	18-12	.032 ±.001	TIN	.018 4M BRASS	62056-4
RIGHT HAND	18-12	.032 ±.001	TIN	.018 4M BRASS	62056-3
LEFT HAND	18-12	.032 ±.001	SILVER	.018 PHOS. BRONZE	62056-2
RIGHT HAND	18-12	.032 ±.001	SILVER	.018 PHOS. BRONZE	62056-1
REELING	WIRE SIZE	TAB THK	FINISH	MATERIAL	PART NO

UNLESS OTHERWISE SPECIFIED DIMENSIONS ARE IN INCHES TOLERANCES ON: 2 PL DEC ± _____ 3 PL DEC ± .015 ANGLES ± _____	DR	JR RUTH	2/3/86
	CHK	M FEHER	2/6/86
	APPD	C MEYERS	2/7/86
	APPD	R KUZO	2/7/86
MATERIAL	SEE TABLE	PRODUCT SPEC	_____
FINISH	SEE TABLE	APPLICATION SPEC	_____
	WEIGHT	_____	_____

AMP AMP INCORPORATED Harrisburg, Pa. 17105		
NAME .250 SERIES FLAG FASTON RECEPTACLE		
SIZE B	FSCM NO 00779	DRAWING NO 62056
SCALE NTS	SHEET 1 OF 1	