

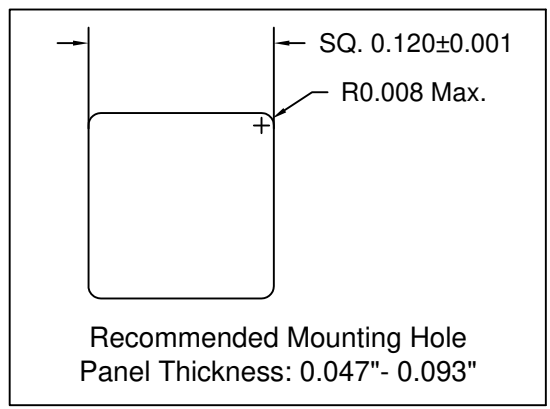

REV.	DESCRIPTION	DATE	APPROVED
A	Engineering Release	07/31/15	J. C.
B	Added Color Options, Sheet #2	01/25/16	J. C.

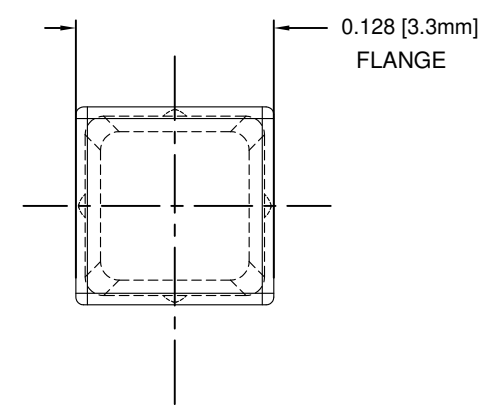

Part No.	X = Body Length
PLPQ3-100	0.100 (2.5mm)
PLPQ3-125	0.125 (3.2mm)
PLPQ3-188	0.188 (4.8mm)
PLPQ3-250	0.250 (6.4mm)
PLPQ3-313	0.313 (7.9mm)
PLPQ3-375	0.375 (9.5mm)
PLPQ3-500	0.500 (12.7mm)
PLPQ3-3MM	3mm (0.118")
PLPQ3-4MM	4mm (0.157")
PLPQ3-5MM	5mm (0.197")
PLPQ3-6MM	6mm (0.236")
PLPQ3-7MM	7mm (0.276")
PLPQ3-8MM	8mm (0.315")
PLPQ3-9MM	9mm (0.354")
PLPQ3-10MM	10mm (0.394")

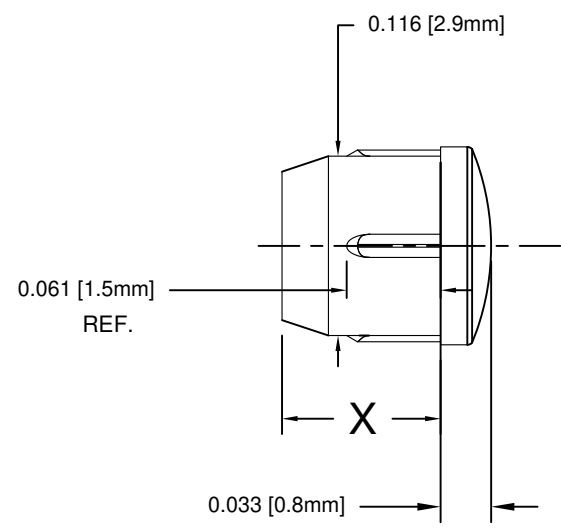
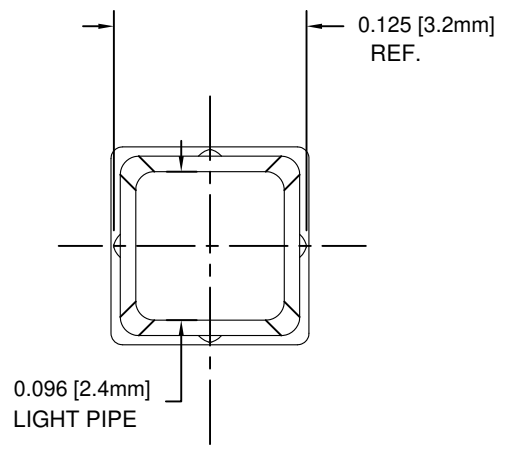
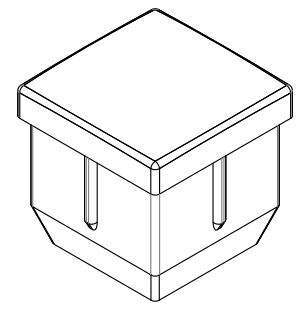

- 2. MATERIAL: POLYCARBONATE, 94V-0, CLEAR
- 1. GENERAL SPECIFICATIONS: BIVAR MOLDED COMPONENT SPECIFICATION BV00-E101 and BSMC-1001.

STANDARD TOLERANCE (UNLESS OTHERWISE SPECIFIED)		 BIVAR [®] 4 THOMAS, IRVINE, CA. 92618 TEL: (949) 951-8808 FAX: (949) 951-3974	
DECIMALS	ANGULAR		
.X ± .1	X° ± 1°	TITLE: SQUARE LIGHT PIPE, LOW PROFILE, 3mm, FRONT MOUNT PART NO: PLPQ3-XXX REVISION: B CAGE CODE : 32559 SHEET # 1 OF 2 <small>CAD GENERATED DOCUMENT. DO NOT MEASURE DRAWING.</small>	
.XX ± .01			
.XXX ± .005			
DESIGNED: Brian Oliver	DATE: 04/24/15		
CHECKED: Alex Wright	DATE: 04/24/15		

OTHER AVAILABLE COLORS

* SEE TABLE FOR ORDERING INFORMATION

REV.	DESCRIPTION	DATE	APPROVED
	SEE SHEET #1		

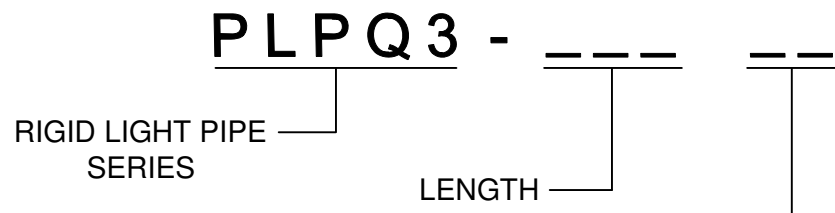

COLOR	Order Code
BLUE	BE
BLACK	BK
GREEN	GN
GRAY	GY
RED	RD
YELLOW	YW

NOTE: LEAVE ORDER CODE BLANK IF NO COLOR IS DESIRED.

3. PARTS ARE DYED TO COLOR UPON REQUEST.

STANDARD TOLERANCE (UNLESS OTHERWISE SPECIFIED) DECIMALS ANGULAR		BIVAR [®] 4 THOMAS, IRVINE, CA. 92618 TEL: (949) 951-8808 FAX: (949) 951-3974	
DESIGNED: K. Aukshunas		DATE: 01/25/16	TITLE: SQUARE LIGHT PIPE, LOW PROFILE, 3mm, FRONT MOUNT
CHECKED: J. Chiang		DATE: 01/25/16	PART NO: PLPQ3-XXX REVISION: B
		CAGE CODE : 32559	SHEET # 2 OF 2
<small>CAD GENERATED DOCUMENT. DO NOT MEASURE DRAWING.</small>			