

NOTE: Distance from end of cable center conductor to Ref. Pl. is 0.325

NOTES:

1.0 Materials

- 1.1 Body and Clamp Nut: Steel. Corrosion Resistant per ASTM-A582. UNS No. S30300.
- 1.2 Center Conductor: Beryllium Copper per ASTM-B196. UNS C17300.
- 1.3 Solder Ferrule: Brass per ASTM-B16. UNS C36000.
- 1.4 O-Ring: Silicone Rubber per A-A-59588.
- 1.5 Insulator: PTFE Fluorocarbon per ASTM-D1710.
- 1.6 Dielectric Stop: Polyetherimide Thermoplastic (ULTEM 1000) per ASTM-D5205.

2.0 Finishes

- 2.1 Center Contact and Solder Ferrule: Gold Plate per ASTM-B488 50 Microinches Min. thickness over Electrolytic Nickel Plate per ASTM-B689 50 Microinches Min. thickness.
- 2.2 Body and Clamp Nuts: Passivated per SAE-AMS-2700.
- 2.3 O-Ring and Dielectrics: None.

3.0 Interface: per Crystek Interface Specification CC-SMAJ.

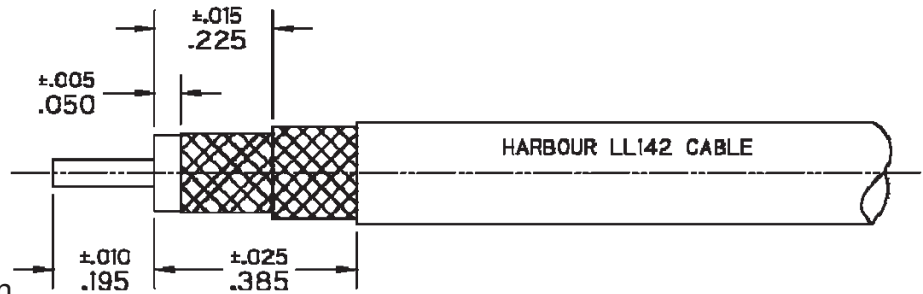
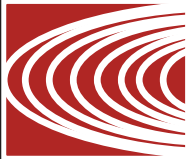

Step 1 1.1 Trim Cable as shown.

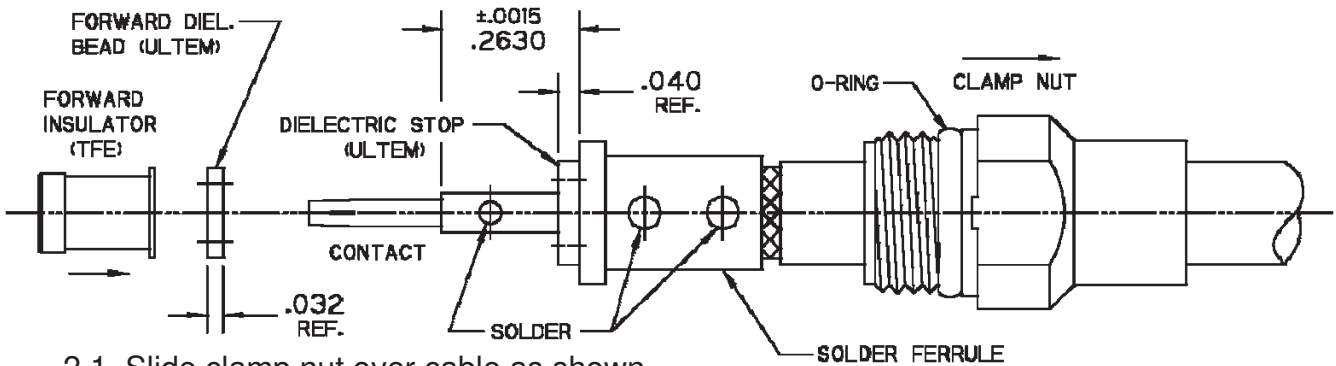

- 2.1 Slide clamp nut over cable as shown.
- 2.2 Solder cable to solder ferrule with dielectric flush with face of ferrule.
- 2.3 Slide dielectric stop (Ø 0.200 OD) over cable center conductor and solder contact flush to stop to dimension shown.
- 2.4 Slide forward insulator and dielectric bead (Ø 0.173 OD) onto contact.

Step 2

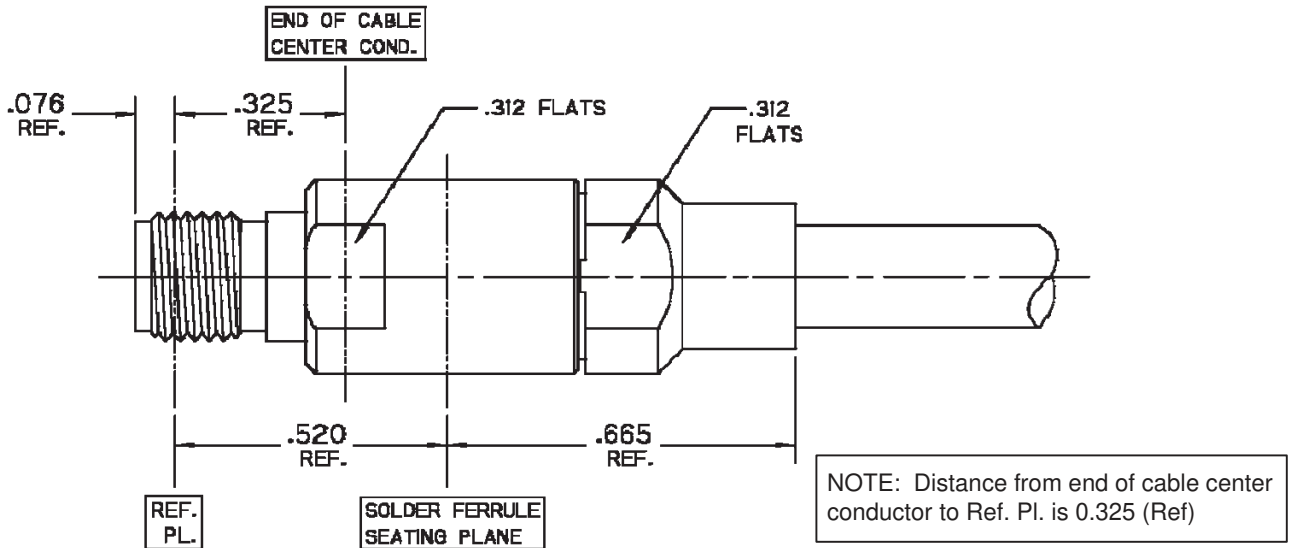

3.1 Insert cable/contact sub-assembly into connector until seated and tighten clamp nut to 25-35 in-lbs.

Step 3

Product Control:

Crystek Part Number:	CS-SF-MHA	Release Date:	04-Jan-11
Revision Level:	A	Responsible:	K. Piotrowicz

