

LOC	DIST	REVISIONS			
P	LTB	DESCRIPTION	DATE	DWN	APVD
FX	00	A	INITIAL RELEASE PER D08-093	14JUL2008	RGV WTW

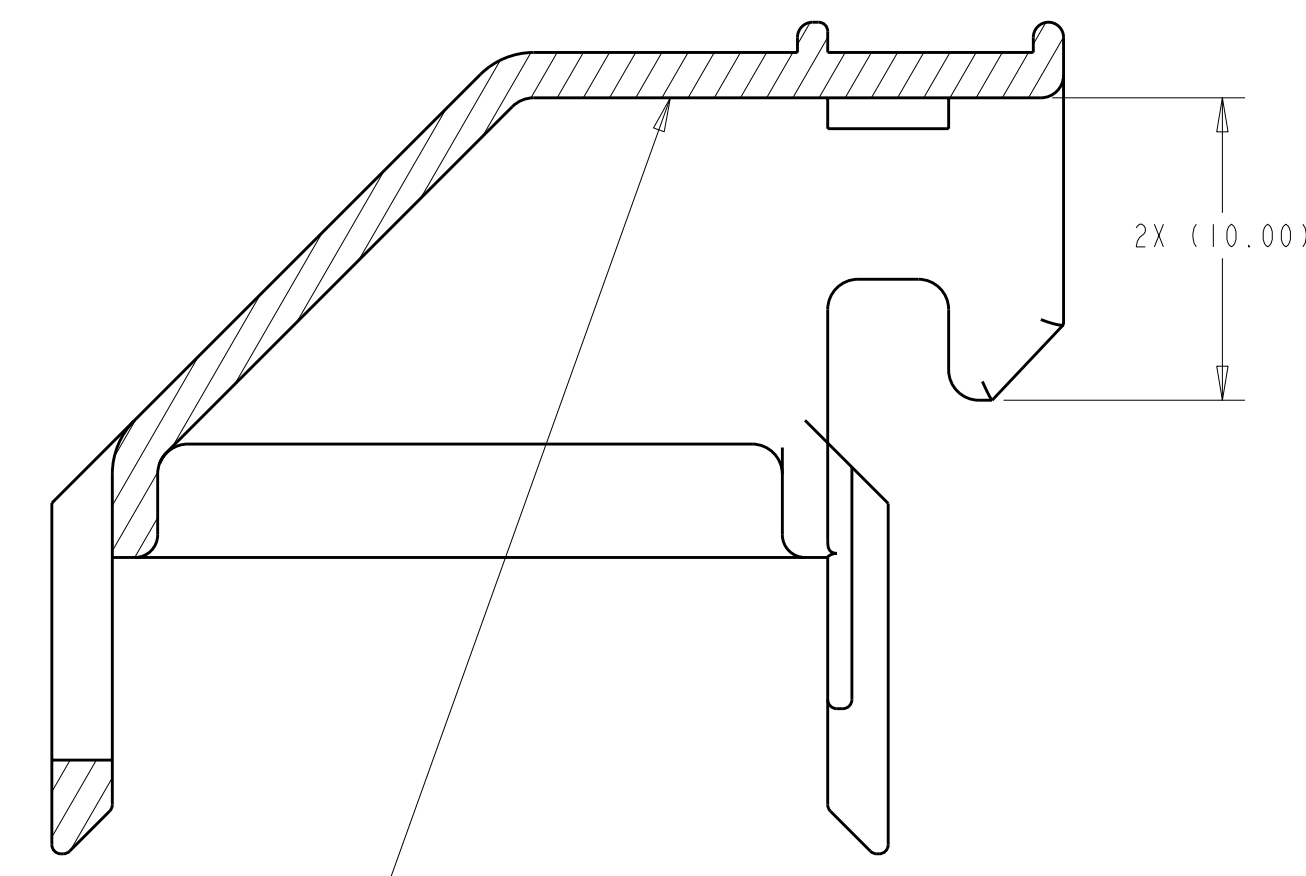
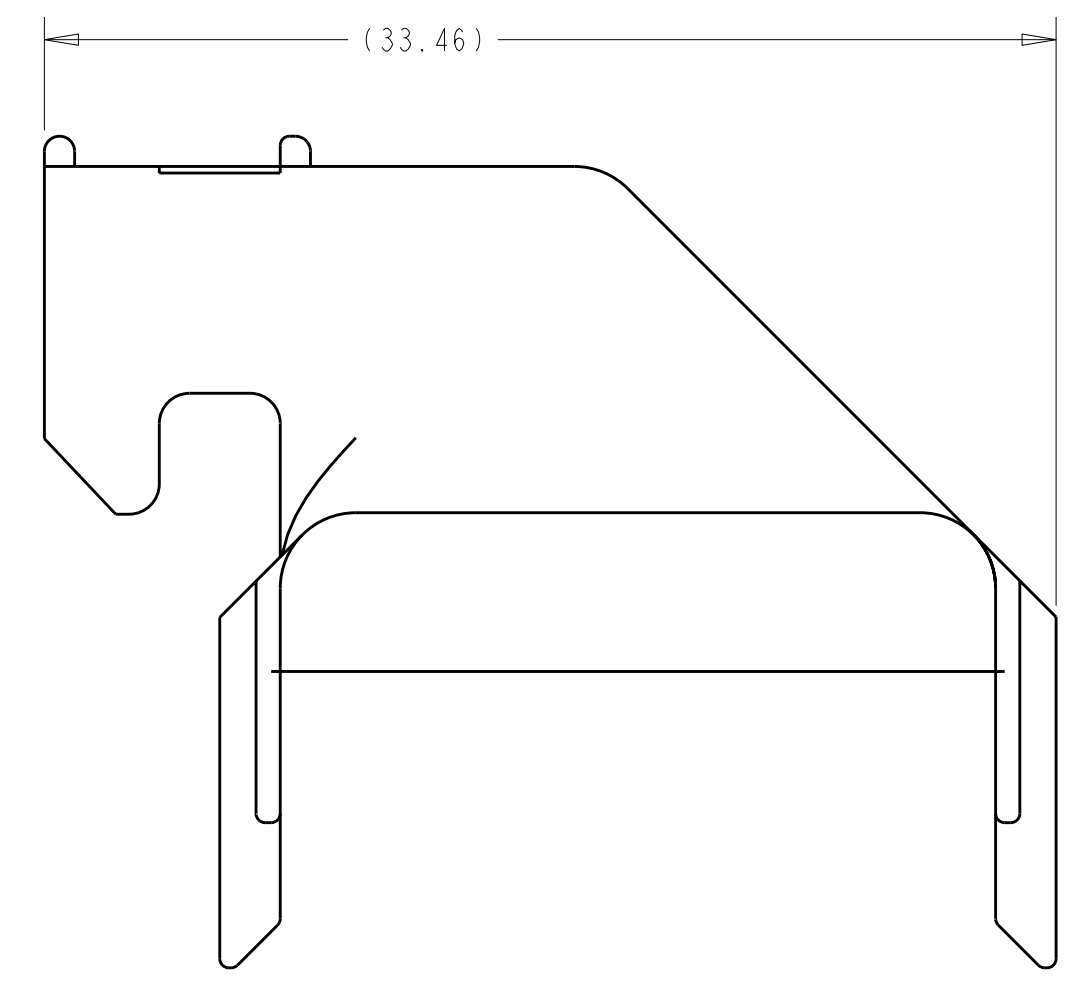
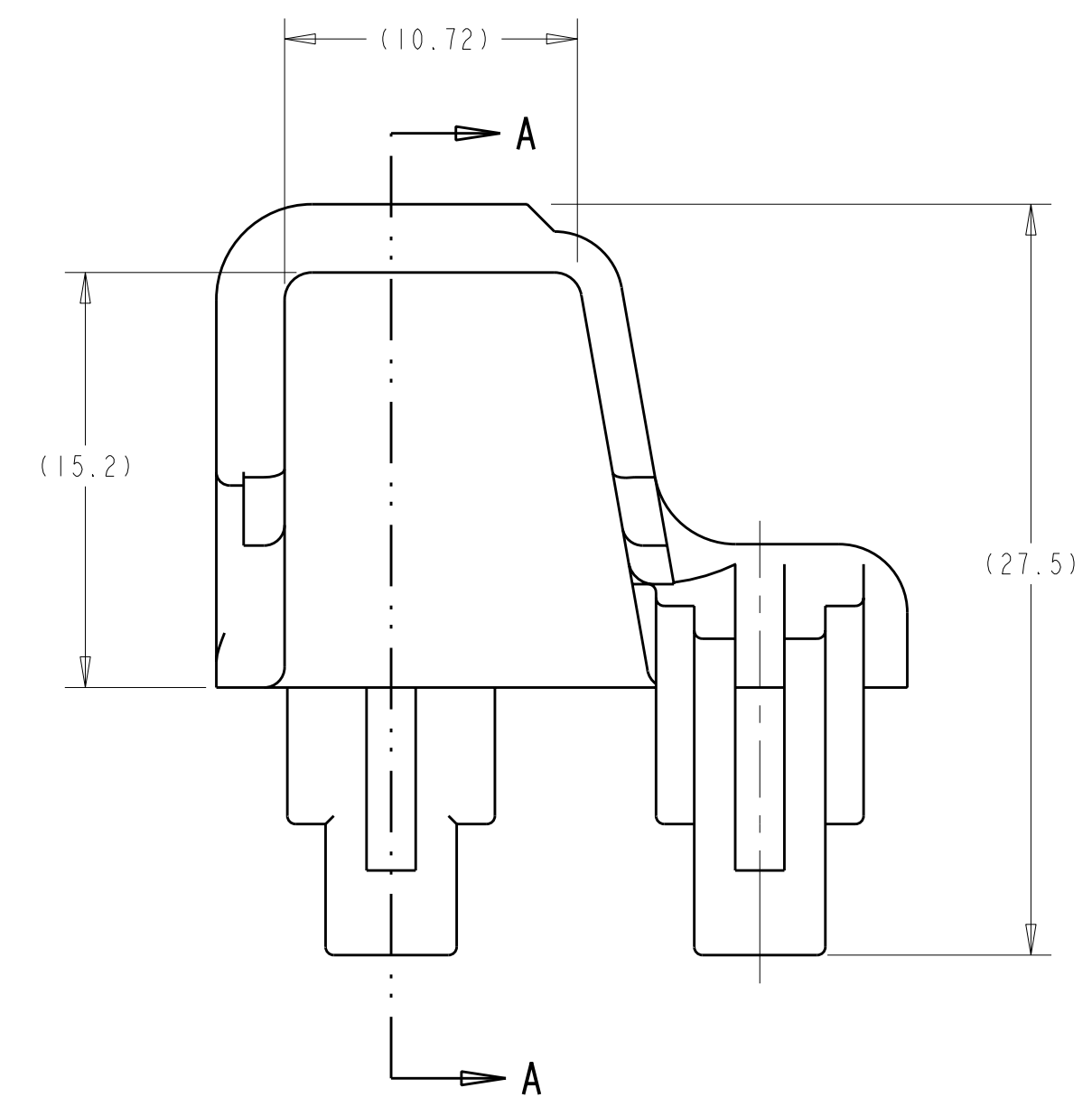
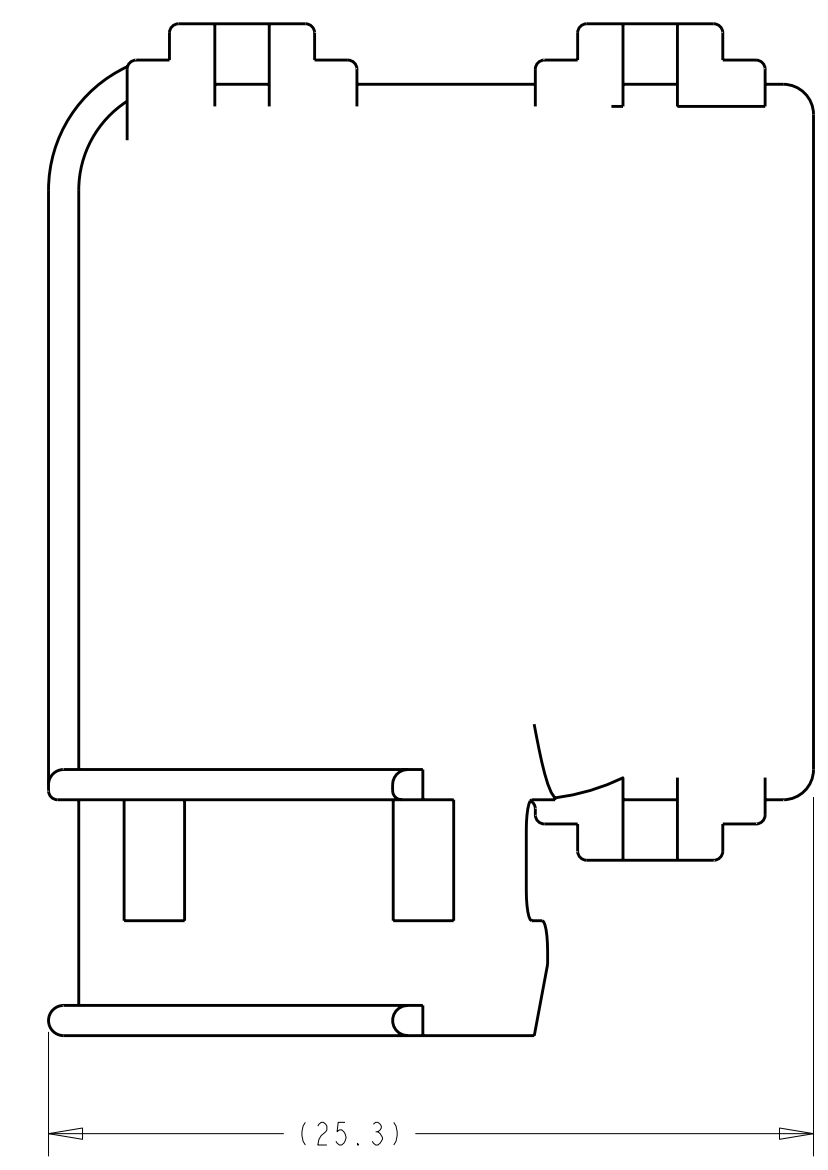
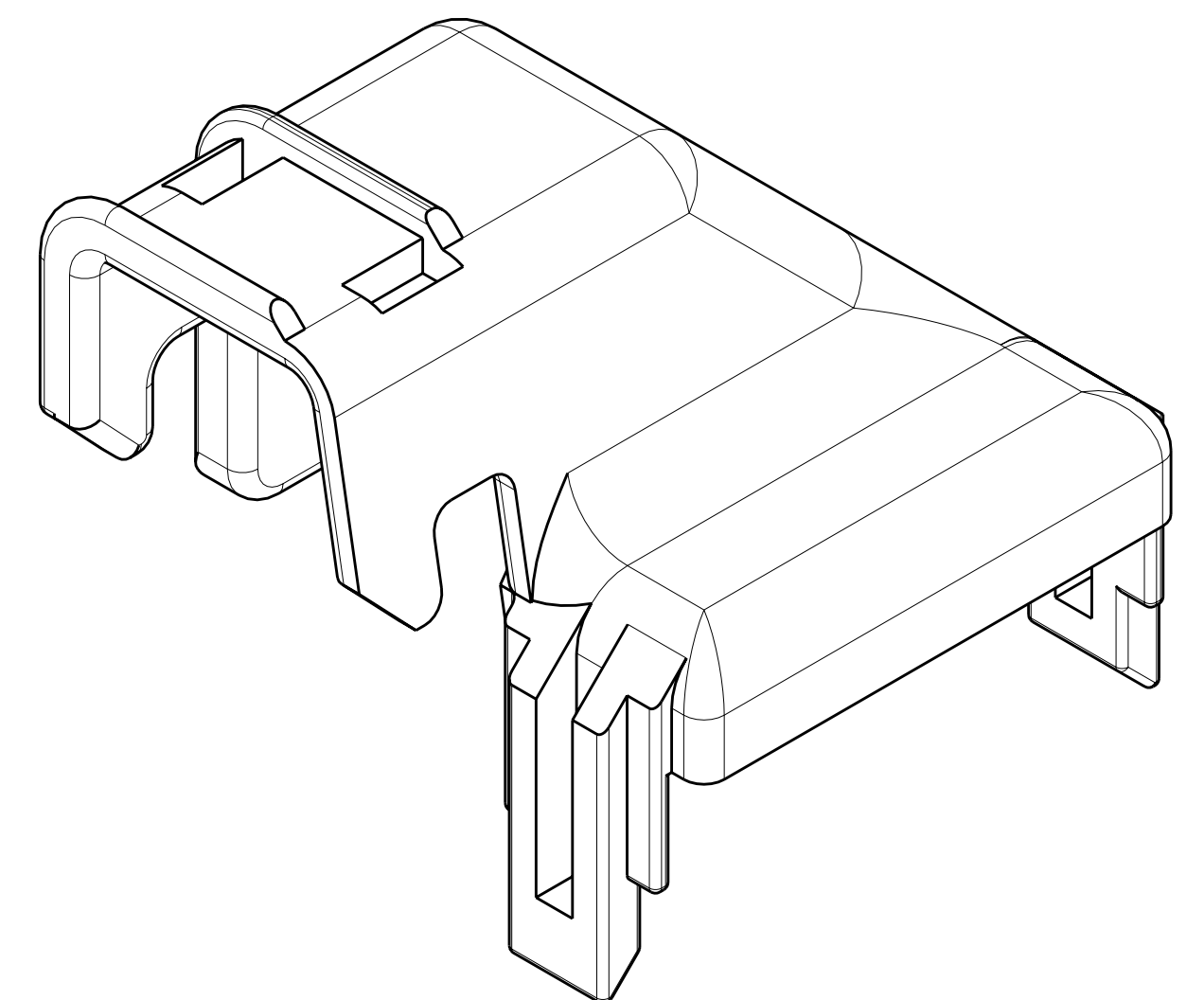
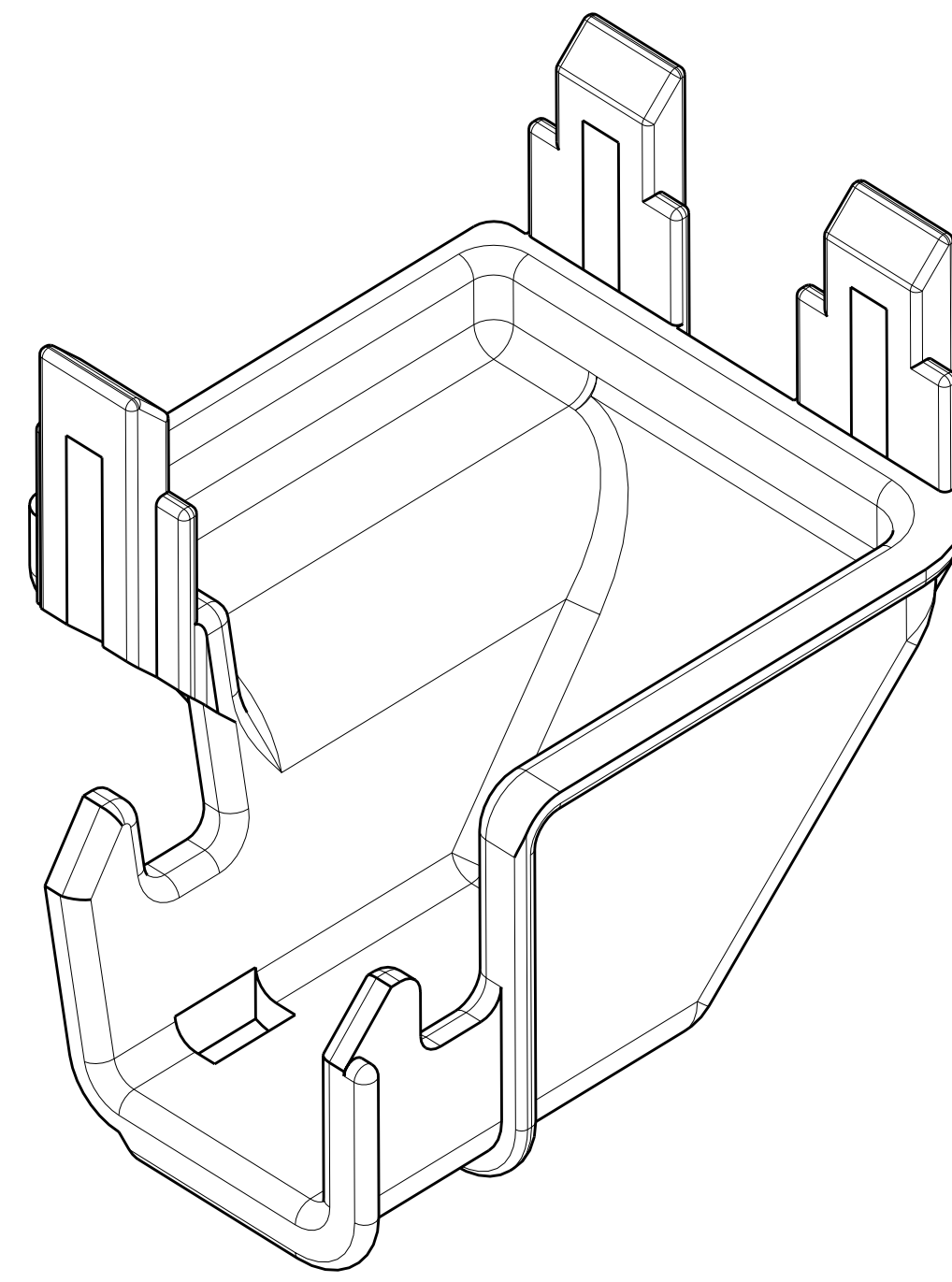

SECTION A-A

- 1. MATERIAL: POLYPROPYLENE
COLOR: BLACK
- 2. MOLD FORD LOGO, PART NUMBER, CAVITY I.D. AND MATERIAL RECYCLING CODE LOCATED ON THIS SURFACE. FOR ALTERNATE PART NUMBERS AND/OR LOGOS CONTACT TYCO ELECTRONICS PRODUCT ENGINEER.
- 3. 25% MAXIMUM REGRIND.

>PP<		BLACK	IFIT-14N003-CA	7-1419157-8
MATERIAL	COLOR	CUSTOMER PART NO	PART NO	
DWN: R. VESTAL 14JUL2008		Tyco Electronics Harrisburg, PA 17105-3608		
CHK: W. WELLINSKY 14JUL2008		NAME: 24 WAY AIRBAG WIRE SHIELD		
APVD: W. WELLINSKY 14JUL2008		PRODUCT SPEC: -		
APPLICATION SPEC: -		SIZE: CAGE CODE: DRAWING NO: RESTRICTED TO: -		
MATERIAL: -		WEIGHT: 1.96g	A 00779 C=7-1419157-8	
FINISH: -		CUSTOMER DRAWING		
DIMENSIONS: mm		SCALE: 4:1		
TOLERANCES UNLESS OTHERWISE SPECIFIED:		SHEET 1 OF 1		
0 PLC ±		REV A		
1 PLC ±				
2 PLC ±				
3 PLC ±				
4 PLC ±				
ANGLES ±				