



Data Sheet

SMT-2240-T-3-R

Features:

- 95 dB output with 12Vp-p and 4000 Hz input
- Hand and reflow solder acceptable
- Only draw 12 mA of current at rated voltage

Specifications

Parameters	Values	Units
Rated Voltage	12	Vp-p
Operating Voltage Range	1 ~ 30	Vp-p
Current Draw at Rated Voltage	≤12	mA
Capacitance	19000±30%	pF
Minimum SPL @ 10cm	≥95	dBA
Resonant Frequency	4000±500	Hz
Housing Material	PPS	-
Weight	2.8	Grams
Acceptable Soldering Methods	Hand Solder, Reflow Solder	See page 2 for soldering information
Environmental Compliances	RoHS	-
Storage Temperature	-30 ~ +80	°C
Operating Temperature	-20 ~ +70	°C

Measurement Method (12Vp-p, 4000Hz, 50% duty cycle square wave with a SPL meter at 10cm)

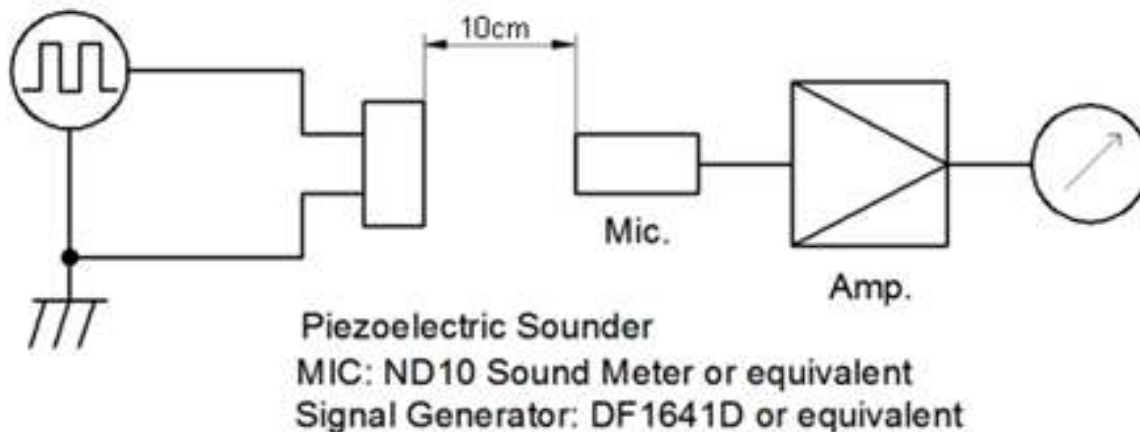

Typical Frequency Response (12Vp-p sine-sweep with microphone spaced at 10 cm)

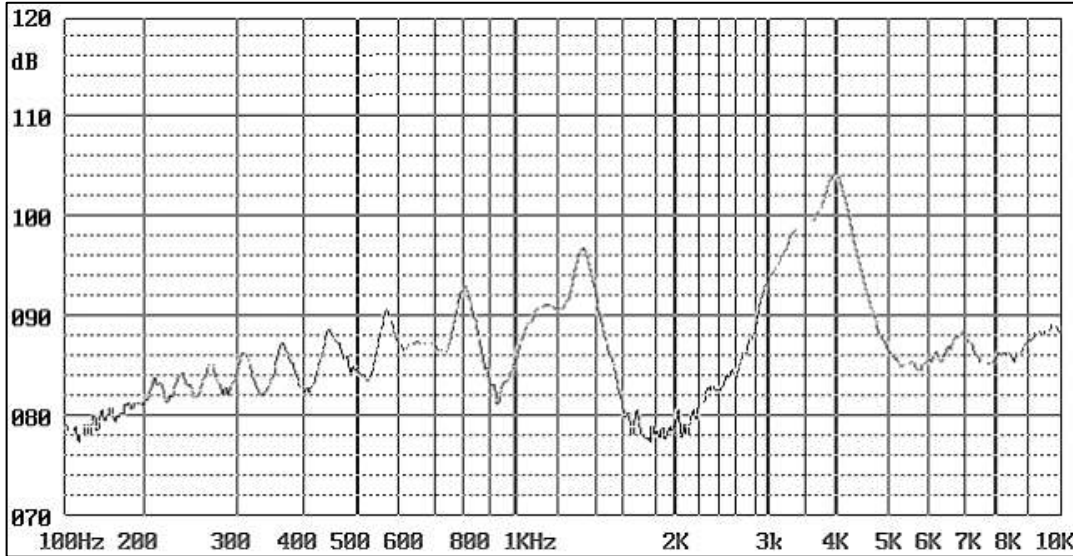

Recommended Soldering Procedure

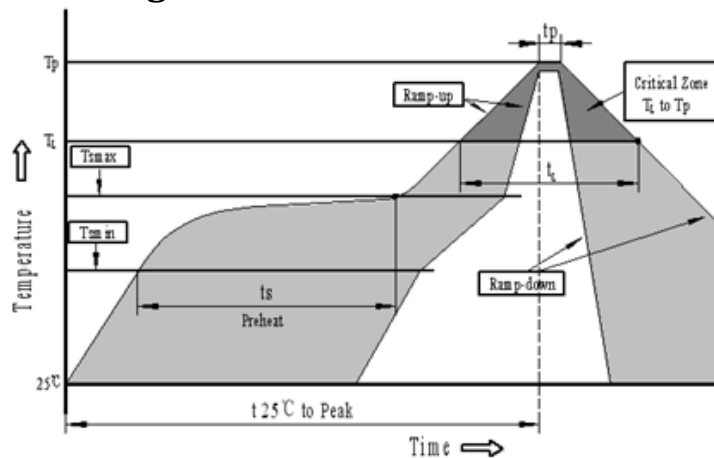

Profile Feature	Pb-Free Assembly
Average ramp-up rate(T_L to T_p)	3°C/second max.
Preheat	
-Temperature Min. (T_{smin})	150°C
-Temperature Min. (T_{smax})	200°C
-Temperature Min. (t_s)	60~180 seconds
T_{smax} to T_L	
-Ramp-up Rate	3°C/second max.
Time maintained above:	
- Temperature(T_L)	217°C
-Time(T_L)	60~150 seconds
Peak temperature(T_p)	260°C+0/-5°C
Time within 5°C of actual Peak temperature (t_p)	6 seconds max.
Ramp-down Rate	6°C/second max.
Time 25°C to Peak Temperature	8 minutes max.

Reliability Testing

Type of Test	Test Specifications
High Temperature Test	The part shall be capable of withstanding a storage temperature of +90°C for 120 hours
Low Temperature Test	The part shall be capable of withstanding a storage temperature of -40°C for 120 hours
Humidity Test	40±2°C, 90~95% RH, 120 hours
Temperature Cycle Testing	Total 5 cycles, 1 cycle consisting of: -40±2°C, 30 minutes 20±5°C, 15 minutes 90±2°C, 30 minutes 20±5°C, 15 minutes
Vibration Test	To-and-fro. sweep time (from 10 to 55 Hz and then 55 to 10) under single amplitude of 1.0mm is 1 minute. The vibration test shall consist of 2 hours per plane in each three mutually perpendicular planes for a total time of 6 hours.
Shock Test	Sounder shall be measured after being applied a shock (980m/s ²) for each three mutually perpendicular directions to each of 3 times by a half sine wave.
Drop Test	Dropped from 7m onto the surface of a 10mm thick wooden board. Applied to the top and side of the part.

After being placed at room temperature for 4 hours, the product shall meet specifications. SPL should be within ±10dB compared with initial value.

Dimensions (Units: mm Tolerance: ±0.5mm)

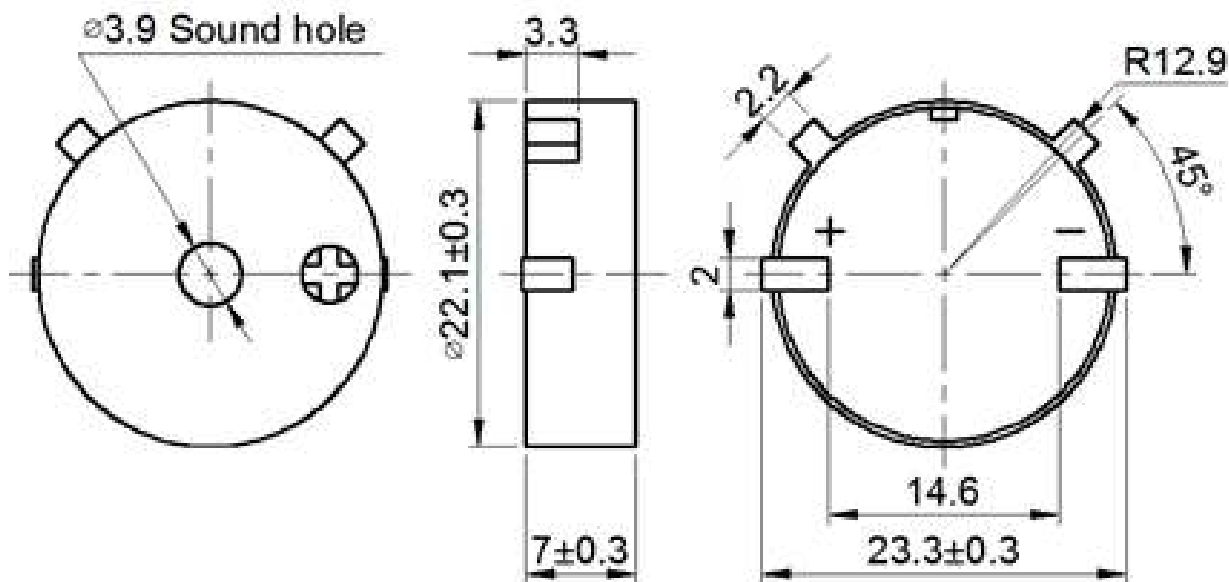

Suggested Land Pattern*

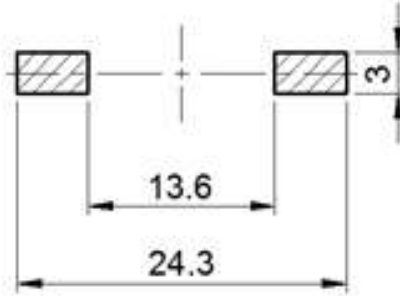

*This land pattern is advisory only and its use or adaptation is entirely voluntary. PUI Audio disclaims all liability of any kind associated with the use, application, or adaptation of this land pattern.

Packaging

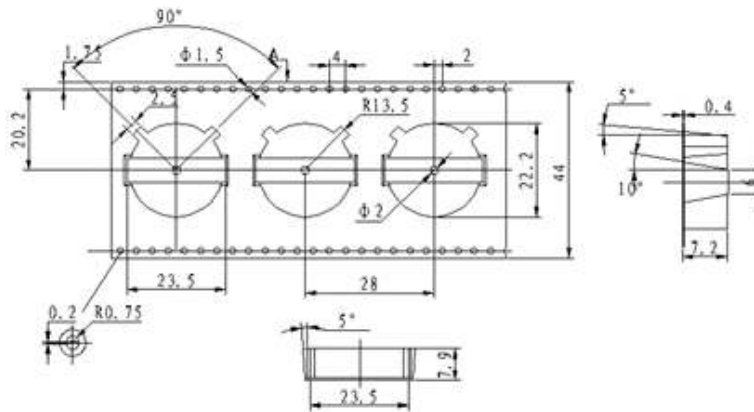

- NOTE:
1. 1.10 sprocket hole pitch cumulative tolerance $\pm 0.2\text{mm}$.
 2. All dimensions meet EIA-481-D requirements.
 3. Thickness: $0.4 \pm 0.05\text{mm}$.
 4. Component loaded per 13" reel: 300 pcs.

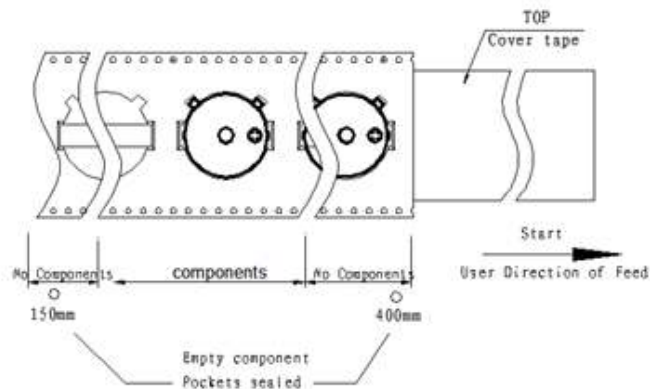
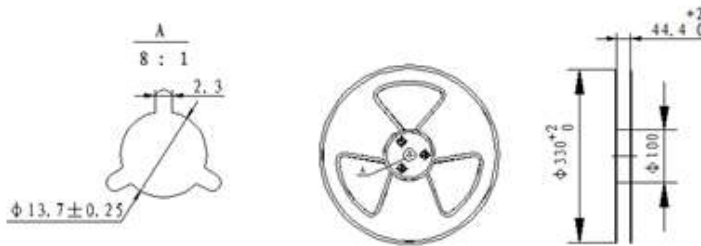

Packaging Cont'd

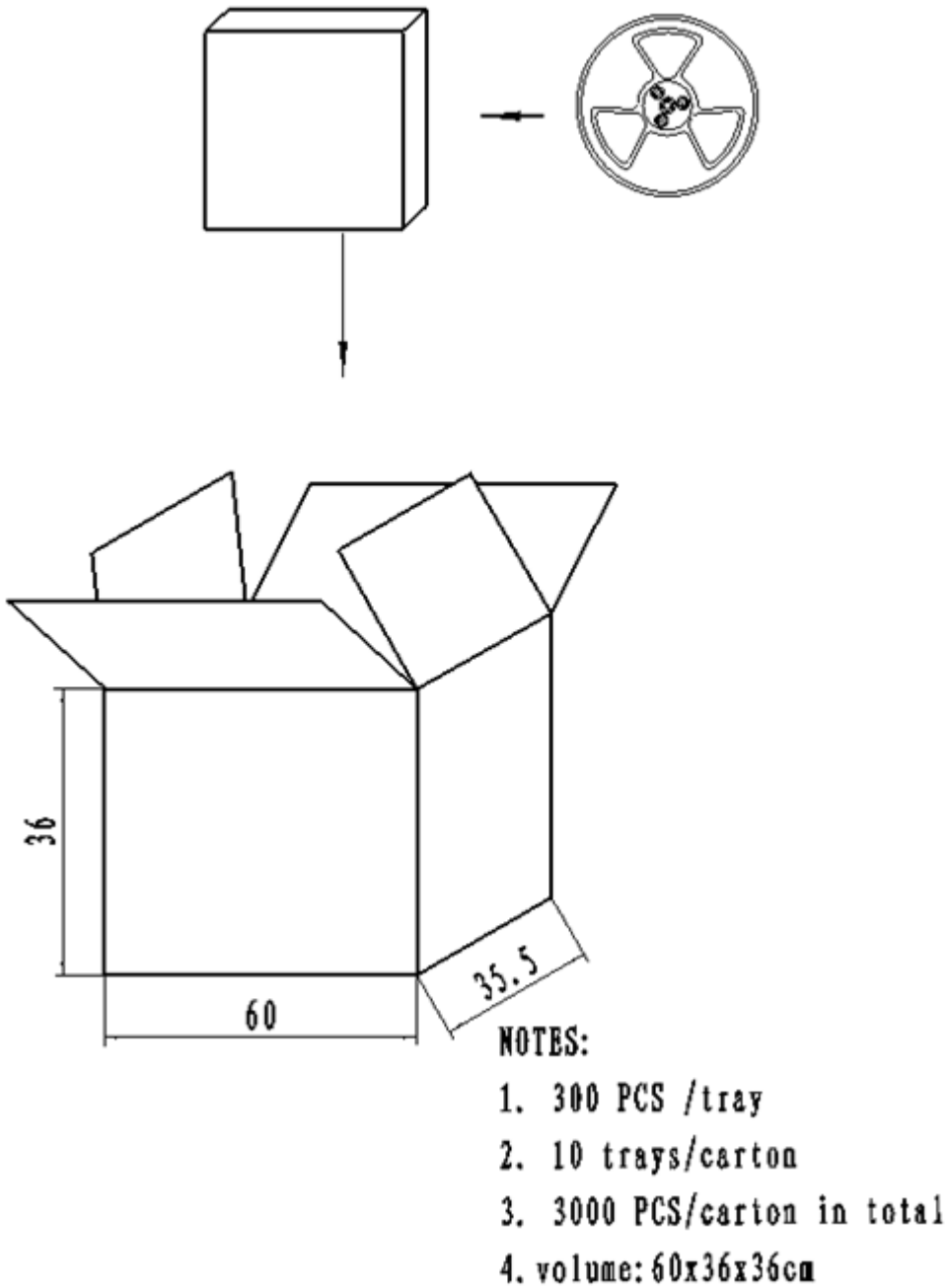

Specifications Revisions

Revision	Description	Date
-	Released from Engineering	5/26/2020

Note:

- 1. Unless otherwise specified:
 - A. All dimensions are in millimeters.
 - B. Default tolerances are $\pm 0.5\text{mm}$ and angles are $\pm 3^\circ$.
- 2. Specifications subject to change or withdrawal without notice.