

PART NUMBER	REVISION	DESCRIPTION	FEED TYPE
2151430-1	F	FINE CRIMP HEIGHT ADJUST	MECHANICAL
2151430-2	G	FINE CRIMP HEIGHT ADJUST	PNEUMATIC
7-2151430-1	F	MECHANICAL AND CRIMP TOOLING KIT	MECHANICAL
7-2151430-2	G	PNEUMATIC AND CRIMP TOOLING KIT	PNEUMATIC
7-2151430-7	A	CRIMP TOOLING KIT	-

ATLANTIC VERSION TERMINATOR INTERFACE ADAPTER

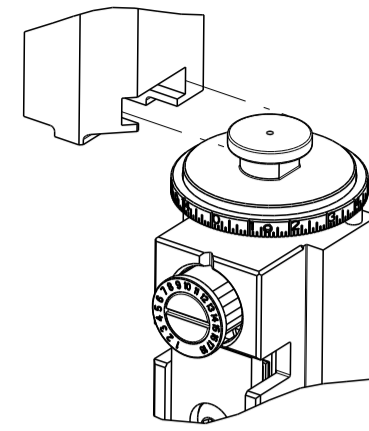

APPLICATOR DATA		
CRIMP	SIZE	TYPE
WIRE	1.00 mm [.039]	F
INSUL	1.40 mm [.055]	F

APPLICATOR INSTRUCTIONS  
408-35042

TERMINAL DATA: MOLEX TERMINAL		MOLEX CRIMP SPECIFICATION	
TERMINAL NAME: 2.00mm PITCH MILLI-GRID TERMINAL			
WIRE STRIP LENGTH		INSULATION DIAMETER RANGE	
1.30-1.80 mm [.051-.071 IN]		Ø0.80-1.40 mm [.031-.055 IN]	
TERMINAL APPLICATION SPECIFICATION	ATS-639005200 Rev. -		
TERMINALS APPLIED			
TE TERMINAL	MOLEX TERMINAL	TE TERMINAL	MOLEX TERMINAL
994698-1	50394-8052	1642397-1	50212-8000
994698-2	50394-8051	1949068-1	50394-8053
621528-1	50394-8051	1949068-2	50394-8054
1642396-1	50394-8051		

WIRE SIZE	CRIMP HEIGHT mm [INCH]	CRIMP HEIGHT REFERENCE SETTING
24 AWG OR 0.20mm <sup>2</sup>	0.64+/-0.05 [.025+/-0.002]	8.6
26 AWG OR 0.12mm <sup>2</sup>	0.61+/-0.05 [.024+/-0.002]	8.9
28 AWG OR 0.08mm <sup>2</sup>	0.58+/-0.05 [.023+/-0.002]	9.2
30 AWG OR 0.05mm <sup>2</sup>	0.56+/-0.05 [.022+/-0.002]	9.4

- 1. RECOMMENDED SPARE PARTS.
- 2. REFER TO SUPPLIED INSTRUCTION SHEET FOR CLEANING, LUBRICATION AND STORAGE OF APPLICATOR.
- 3. APPLY PART NUMBER 1-23419-5 LOCTITE TO THREADS OF ITEM 50. APPLY PART NUMBER 2-23419-6 LOCTITE TO THREADS OF ITEM 242.
- 4. CRIMP HEIGHT REFERENCE SETTING WAS THE SETTING USED WHEN THE APPLICATOR WAS QUALIFIED AT THE FACTORY. ADJUSTMENT MAY BE NECESSARY WHEN RUNNING APPLICATOR IN THE FIELD.
- 5. 30 AWG / 0.05mm<sup>2</sup> WIRE SIZE IS NOT RECOMMENDED BY TE. BUT CAN BE USED AT CUSTOMERS DISCRETION.
- 6. UNLESS SPECIFIED OTHERWISE TORQUE VALUES SHALL BE USED PER DOCUMENT, 101-35000.
- 7. USE TERMINAL SUPPORT LOCATION SHOWN FOR TERMINALS WITH LOCKING LANCE.

**\*WARNING**  
ON INSTALLATION, SET WIRE DISC TO CRIMP HEIGHT REFERENCE SETTING FOR LARGEST WIRE SIZE. CRIMP HEIGHT REFERENCE SETTINGS GREATER THAN THE VALUE SHOWN MAY CAUSE DAMAGE TO THE CRIMP TOOLING, REFER TO THE INSTRUCTION SHEET FOR PROPER SETUP AND ADJUSTMENTS.

**ATLANTIC VERSION**  
Shown on sheets 1 of 4 & 2 of 4  
(Pacific version shown on sheets 3 of 4 & 4 of 4)

LOC	DIST	REVISIONS					
A	66	P	LTN	DESCRIPTION	DATE	OWN	APVD
		D		ECR-18-006969	09MAY2018	FL	JD
		E		ECR-18-007653	17MAY2018	AW	CT
		F		ECR-18-015728	03OCT2018	JAH	CT
		G		ECR-21-121975	24NOV2021	JWC	TE

-	1	-	1	-	2119641-1	FEED CAM, AIR FEED	248	
-	1	1	1	1	2119082-8	CAM, SNAIL, INSULATION ADJUSTMENT	244	
-	1	1	1	1	2079764-1	WASHER, WAVE SPRING, CREST-TO-CREST	243	
-	1	1	1	1	2119083-1	RETAINER, INSULATION DIAL	242	
-	1	1	1	1	7-18023-7	SCR, SKT HD CAP M3 X 4.0	241	
-	-	1	-	1	2119580-1	MECHANICAL FEED ASSEMBLY	239	
-	1	-	1	-	2844940-1	AIR FEED MODULE	238	
-	2	2	2	2	1-2079383-0	SCR, BHSC, RoHS (M3 X 6)	230	
-	1	1	1	1	1-1976053-0	LOCATER BLOCK, TERMINAL	179	
-	1	1	1	1	9931111-1	PIN, SLOTTED SPRING 3.0 X 20.0	177	
-	1	1	1	1	8-22280-7	SPRING, COMPRESSION	176	
-	1	1	1	1	1752353-2	GUIDE PIN, HOLDDOWN	175	
-	1	1	1	1	1901680-2	GUIDE PIN, HOLDDOWN	174	
-	REF	REF	REF	REF	994970-2	COUNTER, MAGNETIC	164	
-	1	1	1	1	1-18028-2	WASHER, FLAT, REG M4	119	
-	1	1	1	1	2844908-1	SCREW, LOCKING	99	
-	1	1	1	1	2844907-1	POST, LOCKING	98	
-	1	1	1	1	1-455888-7	SPACER, CRIMPER	82	
-	1	1	1	1	1803607-3	DOCUMENTATION PACKAGE	71	
-	1	1	1	1	2-2119791-2	DEPRESSOR, WIRE	70	
-	1	1	1	1	2119740-1	TAG, IDENTIFICATION	67	
-	2	2	2	2	2168078-1	SCREW, DRIVE, RH, RoHS, 2 x .188	66	
-	1	1	1	1	2168083-2	SCR, SKT HD CAP, RoHS, M4 X 8.0	60	
-	1	1	1	1	5-18022-5	SCR, HEX HD CAP, M4 X 6.0	59	
-	1	1	1	1	1338685-1	PAWL, FEED	56	
-	4	4	4	4	2168083-3	SCR, SKT HD CAP, RoHS, M4 X 12.0	54	
-	1	1	1	1	1-5018030-0	NUT, HEX, REG, RoHS, M3.5	52	
-	1	1	1	1	1901681-4	HOLDDOWN, TERMINAL	51	
-	1	1	1	1	1752354-7	STANDOFF, HOLD-DOWN	50	
-	1	2	1	2	18023-9	SCR, SKT HD CAP M4 X 6.0	49	
-	-	1	-	1	2119652-1	FEED CAM, PRE FEED	48	
-	-	1	-	1	2119653-1	FEED CAM, POST FEED	47	
-	1	1	1	1	1803583-9	APPLICATOR BASIC ASSEMBLY, SF	46	
-	1	1	1	1	1803515-3	RAM ASSEMBLY, SF ATLANTIC	44	
-	1	1	1	1	1803602-1	SCR, BHSC, RoHS (M8 X 25)	41	
-	1	1	1	1	2-1752356-5	SUPPORT, TERMINAL	34	
-	2	2	2	2	2079383-5	SCR, BHSC, RoHS (M4 X 20)	33	
-	2	2	2	2	2-2844962-3	SPACER, CYLINDRICAL, STRIP GUIDE	30	
-	1	1	1	1	2844992-1	ASSEMBLY, STRIP GUIDE	29	
-	1	1	1	1	1320928-2	STRIP GUIDE	24	
-	1	1	1	1	2168083-2	SCR, SKT HD CAP, RoHS, M4 X 8.0	21	
-	1	1	1	1	1-18028-2	WASHER, FLAT, REG M4	20	
-	1	1	1	1	2119533-3	STRIPPER, SIDE FEED	19	
-	1	1	1	1	2119806-1	INSERT, SHEAR	13	
-	1	1	1	1	3-22280-3	SPRING, COMPRESSION	12	
-	1	1	1	1	1-356885-3	STOP, SHEAR	11	
-	1	1	1	1	2119805-1	SHEAR HOLDER, FRONT	10	
-	1	1	1	1	1803095-6	FLOATING SHEAR, FRONT	9	
-	1	2	2	1	1	7-1633139-3	ANVIL, COMBINATION	8
-	-	-	-	-	-	-	7	
-	-	-	-	-	-	-	6	
-	1	1	1	1	2119757-5	DEPRESSOR, SHEAR	5	
-	1	1	1	1	2-238011-0	BLOCK, CRIMPER SPACER	4	
-	1	2	2	1	1	5-1803223-0	CRIMPER, INSULATION F PREMIUM	3
-	1	1	1	1	455888-3	SPACER, CRIMPER	2	
-	1	2	2	1	1	5-1490019-0	CRIMPER, WIRE PREMIUM	1

DIMENSIONS:		TOLERANCES UNLESS OTHERWISE SPECIFIED:		MATERIAL:		FINISH:	
mm	0 PLC ±	1 PLC ±	2 PLC ±	3 PLC ±	4 PLC ±	ANGLES	FINISH

OWN	X. ZHAO	11MAY2012
CHK	T. ELBIN	11MAY2012
APVD	S. XI	11MAY2012
PRODUCT SPEC		
APPLICATION SPEC		
SIZE	CAGE CODE	DRAWING NO
A1	00779	2151430
Customer Accessible Production Drawing		SCALE 1:2 SHEET 1 OF 4 REV G

LOC	DIST	REVISIONS					
		P	LTN	DESCRIPTION	DATE	OWN	APVD
A	66	-	-	SEE SHEET 1	-	-	-

# FEED TYPE MECHANICAL

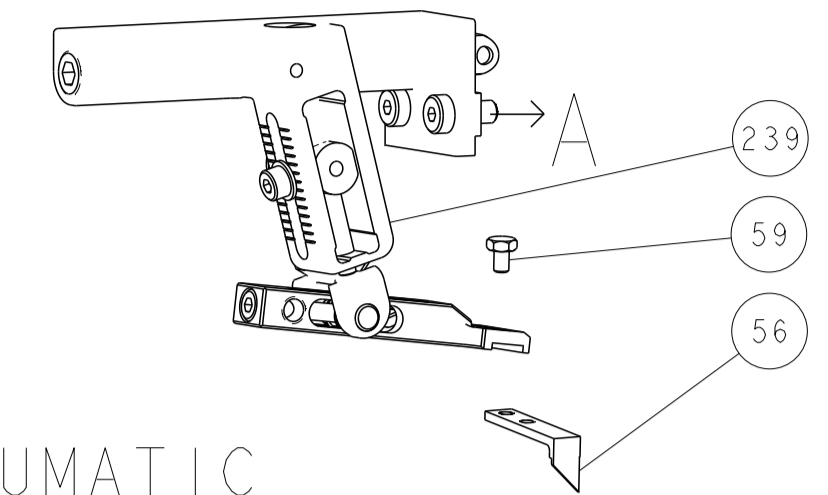

## PNEUMATIC

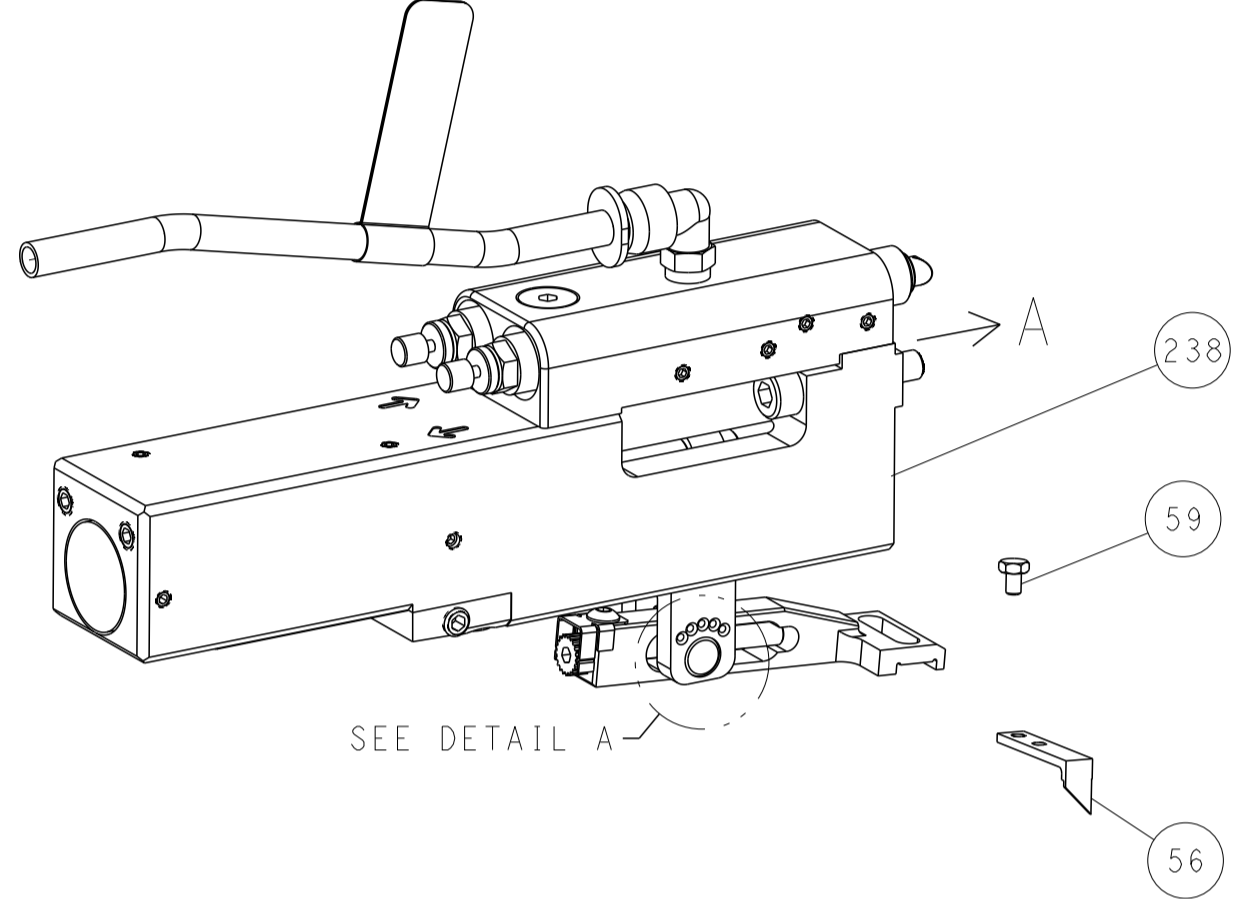

### FEED SPRING SETTING POSITION (SHOWN FROM REAR SIDE)



DETAIL A

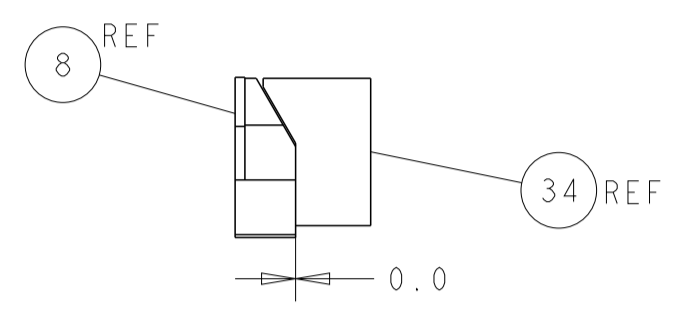
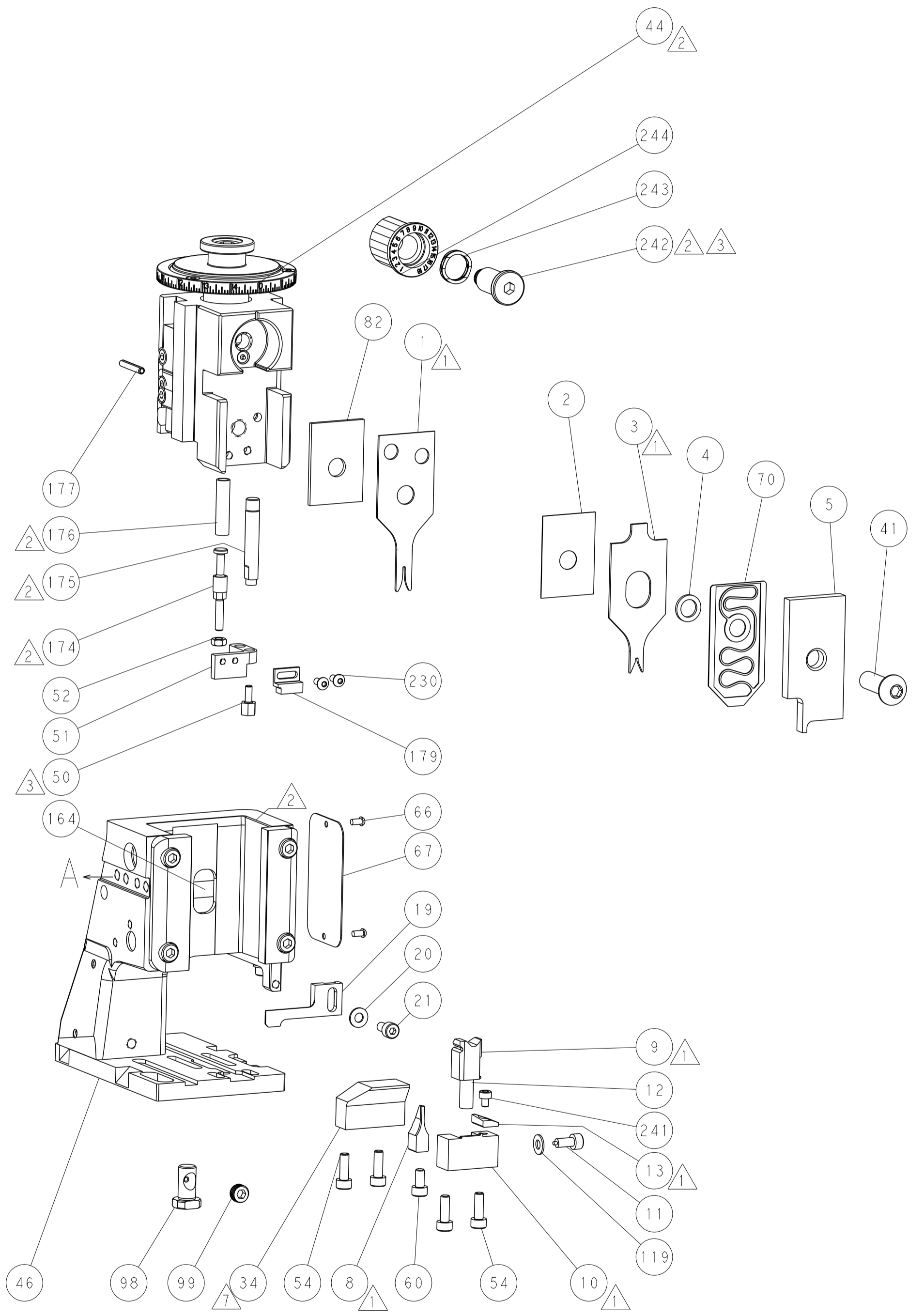
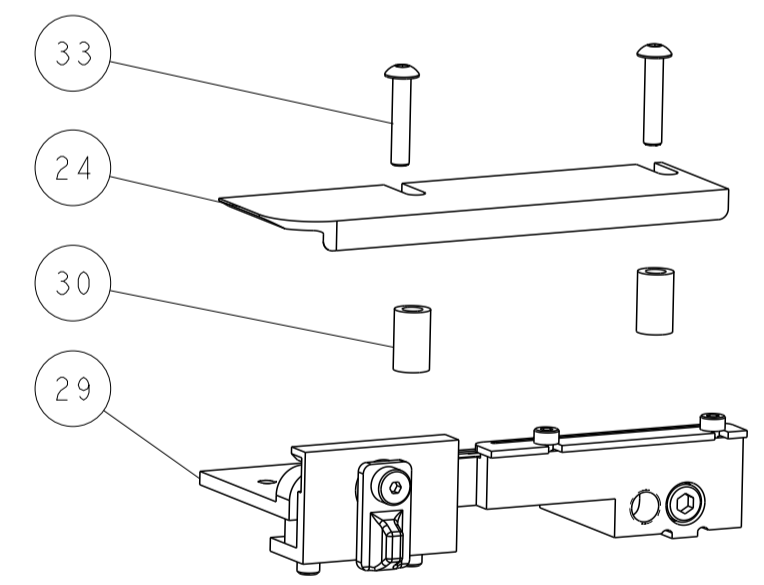

TERMINAL SUPPORT LOCATION

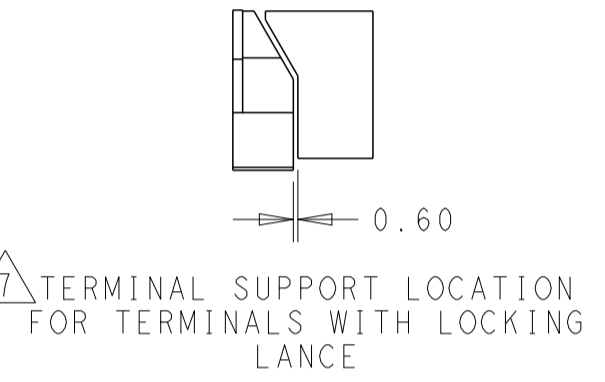

TERMINAL SUPPORT LOCATION FOR TERMINALS WITH LOCKING LANCE

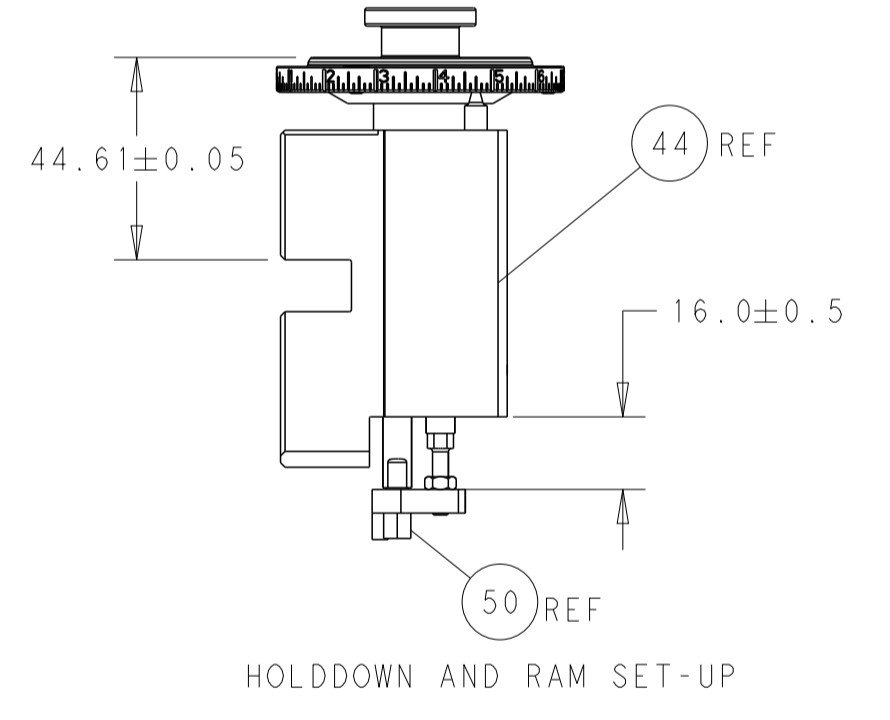

HOLDDOWN AND RAM SET-UP

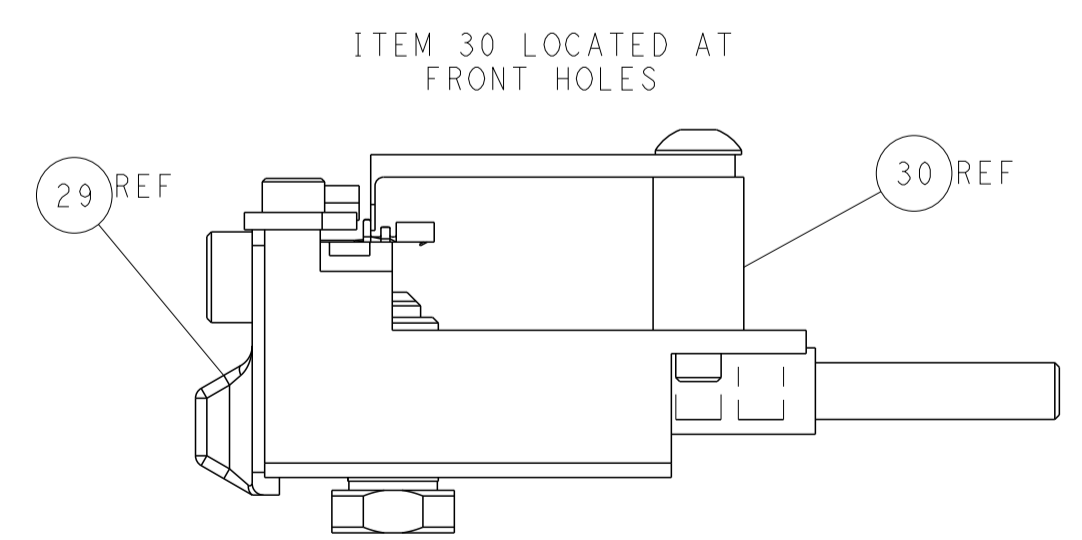

FEED TRACK POSITION GUIDE BY INSULATION BARREL

# CAM POSITIONS

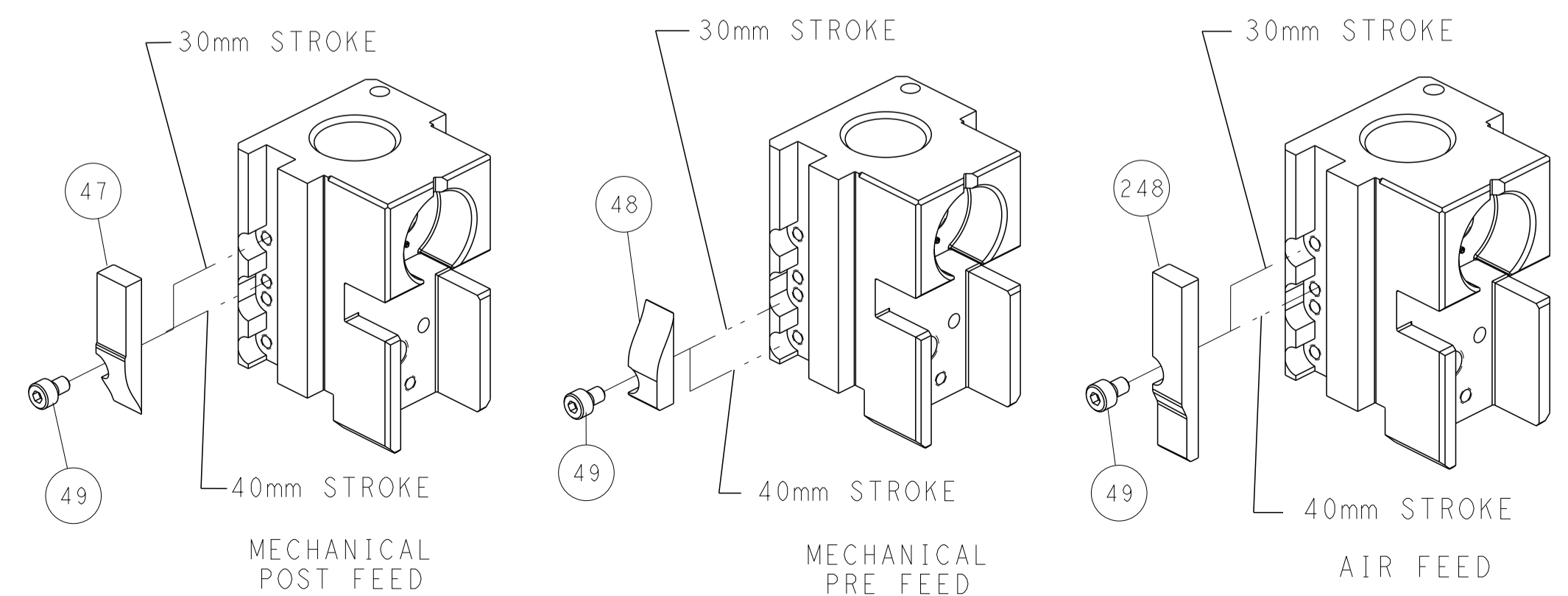

**ATLANTIC VERSION**  
 Shown on sheets 1 of 4 & 2 of 4  
 (Pacific version shown on sheets 3 of 4 & 4 of 4)

DIMENSIONS: mm 		TOLERANCES UNLESS OTHERWISE SPECIFIED: 0 PLC ± 1 PLC ± 2 PLC ± 3 PLC ± 4 PLC ± ANGLES ± FINISH		DWN X.ZHAO 11MAY2012 CHK T.ELBIN 11MAY2012 APVD S.XI 11MAY2012 PRODUCT SPEC APPLICATION SPEC WEIGHT Customer Accessible Production Drawing		NAME Ocean Side Feed Applicator SIZE CAGE CODE DRAWING NO. RESTRICTED TO A1 00779 C=2151430 SCALE 1:2 SHEET 2 OF 4 REV G	
--------------------	--	---	--	--	--	---	--

PART NUMBER	REVISION	DESCRIPTION	FEED TYPE
2-2151430-1	F	FINE CRIMP HEIGHT ADJUST	MECHANICAL
2-2151430-2	G	FINE CRIMP HEIGHT ADJUST	PNEUMATIC
7-2151430-7	A	CRIMP TOOLING KIT	-

PACIFIC VERSION TERMINATOR  
 INTERFACE ADAPTER



APPLICATOR DATA		
CRIMP	SIZE	TYPE
WIRE	1.00 mm [.039]	F
INSUL	1.40 mm [.055]	F

APPLICATOR INSTRUCTIONS  
 408-35042

TERMINAL DATA: MOLEX TERMINAL		MOLEX CRIMP SPECIFICATION	
TERMINAL NAME: 2.00mm PITCH MILLI-GRID TERMINAL			
WIRE STRIP LENGTH	INSULATION DIAMETER RANGE		
1.30-1.80 mm [.051-.071 IN]	Ø0.80-1.40 mm [.031-.055 IN]		
TERMINAL APPLICATION SPECIFICATION ATS-639005200 Rev -			
TERMINALS APPLIED			
TE TERMINAL	MOLEX TERMINAL	TE TERMINAL	MOLEX TERMINAL
994698-1	50394-8052	1642397-1	50212-8000
994698-2	50394-8051	1949068-1	50394-8053
621528-1	50394-8051	1949068-2	50394-8054
1642396-1	50394-8051		

WIRE SIZE	CRIMP HEIGHT mm [INCH]	CRIMP HEIGHT REFERENCE SETTING
24 AWG OR 0.20mm <sup>2</sup>	0.64 +/- 0.05 [.025 +/- .002]	8.6
26 AWG OR 0.12mm <sup>2</sup>	0.61 +/- 0.05 [.024 +/- .002]	8.9
28 AWG OR 0.08mm <sup>2</sup>	0.58 +/- 0.05 [.023 +/- .002]	9.2
30 AWG OR 0.05mm <sup>2</sup>	0.56 +/- 0.05 [.022 +/- .002]	9.4

- RECOMMENDED SPARE PARTS.
- REFER TO SUPPLIED INSTRUCTION SHEET FOR CLEANING, LUBRICATION AND STORAGE OF APPLICATOR.
- APPLY PART NUMBER 1-23419-5 LOCTITE TO THREADS OF ITEM 50. APPLY PART NUMBER 2-23419-6 LOCTITE TO THREADS OF ITEM 242.
- CRIMP HEIGHT REFERENCE SETTING WAS THE SETTING USED WHEN THE APPLICATOR WAS QUALIFIED AT THE FACTORY. ADJUSTMENT MAY BE NECESSARY WHEN RUNNING APPLICATOR IN THE FIELD.
- 30 AWG / 0.05mm<sup>2</sup> WIRE SIZE IS NOT RECOMMENDED BY TE. BUT CAN BE USED AT CUSTOMERS DISCRETION.
- UNLESS SPECIFIED OTHERWISE TORQUE VALUES SHALL BE USED PER DOCUMENT, 101-35000.
- USE TERMINAL SUPPORT LOCATION SHOWN FOR TERMINALS WITH LOCKING LANCE.

**\*WARNING**  
 ON INSTALLATION, SET WIRE DISC TO CRIMP HEIGHT REFERENCE SETTING FOR LARGEST WIRE SIZE. CRIMP HEIGHT REFERENCE SETTINGS GREATER THAN THE VALUE SHOWN MAY CAUSE DAMAGE TO THE CRIMP TOOLING, REFER TO THE INSTRUCTION SHEET FOR PROPER SETUP AND ADJUSTMENTS.

**PACIFIC VERSION**  
 Shown on sheets 3 of 4 & 4 of 4  
 (Atlantic version shown on sheets 1 of 4 & 2 of 4)

LOC	DIST	REVISIONS					
A	66	P	LTN	DESCRIPTION	DATE	OWN	APVD
-	-	-	-	SEE SHEET 1	-	-	-

-	1	1	2119082-8	CAM, SNAIL, INSULATION ADJUSTMENT	244
-	1	1	2079764-1	WASHER, WAVE SPRING, CREST-TO-CREST	243
-	1	1	2119083-1	RETAINER, INSULATION DIAL	242
-	1	1	7-18023-7	SCR, SKT HD CAP M3 X 4.0	241
-	-	1	2119580-1	MECHANICAL FEED ASSEMBLY	239
-	1	-	2844940-1	AIR FEED MODULE	238
-	2	2	1-2079383-0	SCR, BHSC, RoHS (M3 X 6)	230
-	1	1	1-1976053-0	LOCATER BLOCK, TERMINAL	179
-	1	1	993111-1	PIN, SLOTTED SPRING 3.0 X 20.0	177
-	1	1	8-22280-7	SPRING, COMPRESSION	176
-	1	1	1752353-2	GUIDE PIN, HOLDDOWN	175
-	1	1	1901680-2	GUIDE PIN, HOLDDOWN	174
-	REF	REF	994970-2	COUNTER, MAGNETIC	164
-	1	-	2119641-2	FEED CAM, AIR FEED	151
-	1	1	2168083-8	SCR, SKT HD CAP, RoHS, M4 X 16	144
-	4	4	2168083-9	SCR, SKT HD CAP, RoHS, M4 X 20	143
-	-	1	2119653-2	FEED CAM, POST FEED	142
-	1	1	1-1803583-0	APPLICATOR BASIC ASSEMBLY, SF	141
-	1	1	1803516-1	RAM ASSEMBLY, SF PACIFIC	140
-	1	1	1-18028-2	WASHER, FLAT, REG M4	119
-	1	1	2844908-1	SCREW, LOCKING	99
-	1	1	2844907-1	POST, LOCKING	98
-	1	1	1-455888-7	SPACER, CRIMPER	82
-	1	1	1803607-3	DOCUMENTATION PACKAGE	71
-	1	1	2-2119791-2	DEPRESSOR, WIRE	70
-	1	1	2119740-1	TAG, IDENTIFICATION	67
-	2	2	2168078-1	SCREW, DRIVE, RH, RoHS, 2 x .188	66
-	1	1	5-18022-5	SCR, HEX HD CAP, M4 X 6.0	59
-	1	1	1338685-1	PAWL, FEED	56
-	1	1	1-5018030-0	NUT, HEX, REG, RoHS, M3.5	52
-	1	1	1901681-4	HOLDDOWN, TERMINAL	51
-	1	1	1752354-7	STANDOFF, HOLD-DOWN	50
-	1	2	18023-9	SCR, SKT HD CAP M4 X 6.0	49
-	-	1	2119652-1	FEED CAM, PRE FEED	48
-	1	1	1803602-1	SCR, BHSC, RoHS (M8 X 25)	41
-	1	1	2-1752356-5	SUPPORT, TERMINAL	34
-	2	2	2079383-5	SCR, BHSC, RoHS (M4 X 20)	33
-	2	2	2-2844962-3	SPACER, CYLINDRICAL, STRIP GUIDE	30
-	1	1	2844992-1	ASSEMBLY, STRIP GUIDE	29
-	1	1	1320928-2	STRIP GUIDE	24
-	1	1	2168083-2	SCR, SKT HD CAP, RoHS, M4 X 8.0	21
-	1	1	1-18028-2	WASHER, FLAT, REG M4	20
-	1	1	2119533-3	STRIPPER, SIDE FEED	19
-	1	1	2119806-1	INSERT, SHEAR	13
-	1	1	3-22280-3	SPRING, COMPRESSION	12
-	1	1	1-356885-3	STOP, SHEAR	11
-	1	1	2119805-1	SHEAR HOLDER, FRONT	10
-	1	1	1803095-6	FLOATING SHEAR, FRONT	9
-	1	1	7-1633139-3	ANVIL, COMBINATION	8
-	-	-	-	-	7
-	-	-	-	-	6
-	1	1	2119757-5	DEPRESSOR, SHEAR	5
-	1	1	2-238011-0	BLOCK, CRIMPER SPACER	4
-	1	1	5-1803223-0	CRIMPER, INSULATION F PREMIUM	3
-	1	1	455888-3	SPACER, CRIMPER	2
-	1	1	5-1490019-0	CRIMPER, WIRE PREMIUM	1

ITEM NO	PART NO	DESCRIPTION
-77	-22	-21

TE Connectivity Harrisburg, PA 17105-3608	DATE: 11MAY2012 CHK: X.ZHAO T.ELBIN
NAME: Ocean Side Feed Applicator	SIZE: A1
SCALE: 1:2	SHEET: 3 OF 4
REV: G	Customer Accessible Production Drawing

LOC	DIST	REV	DESCRIPTION	DATE	DWN	APVD
A	66	-	SEE SHEET 1	-	-	-

# FEED TYPE MECHANICAL

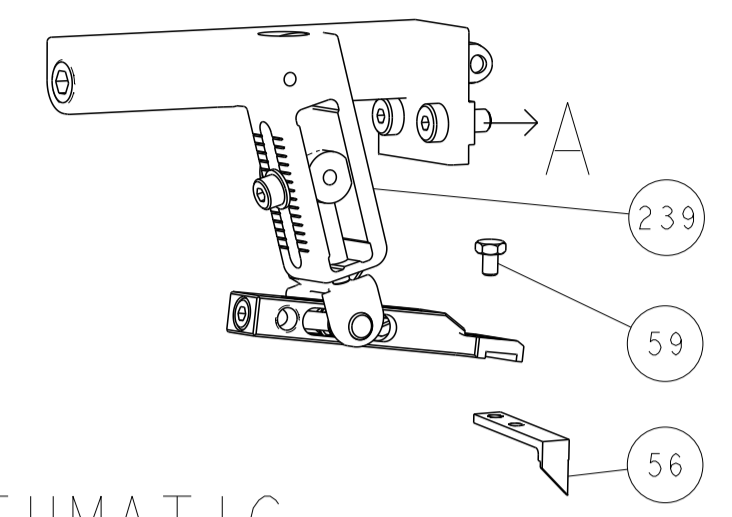

## PNEUMATIC

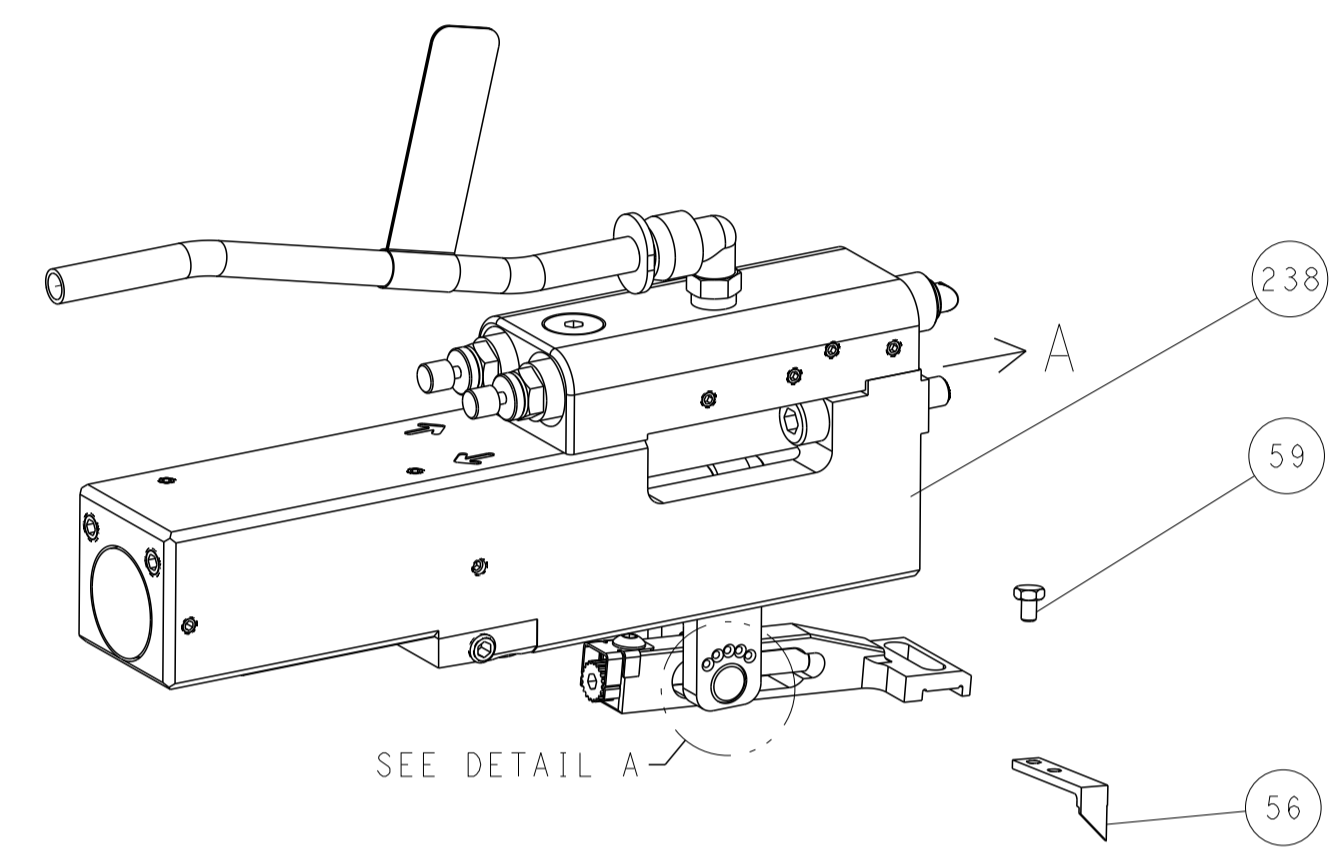

## FEED SPRING SETTING POSITION (SHOWN FROM REAR SIDE)

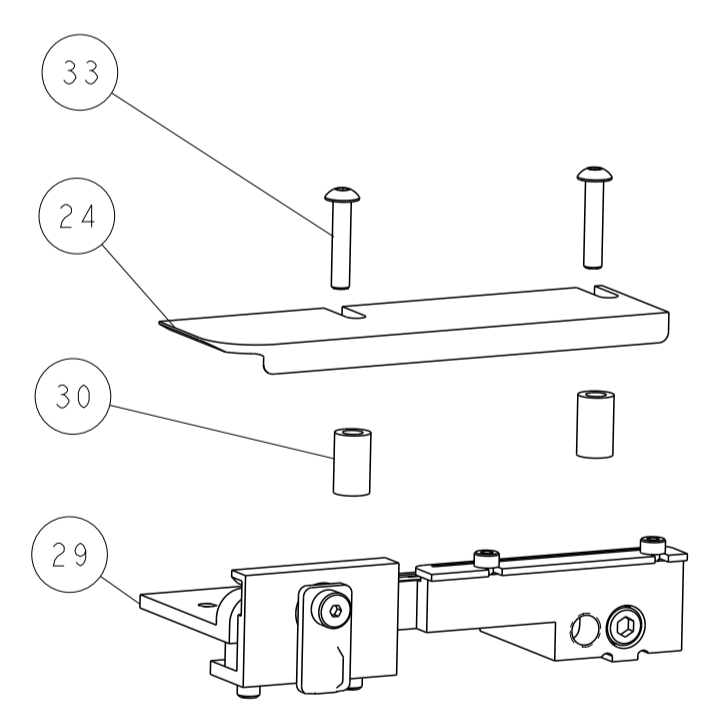

## CAM POSITIONS

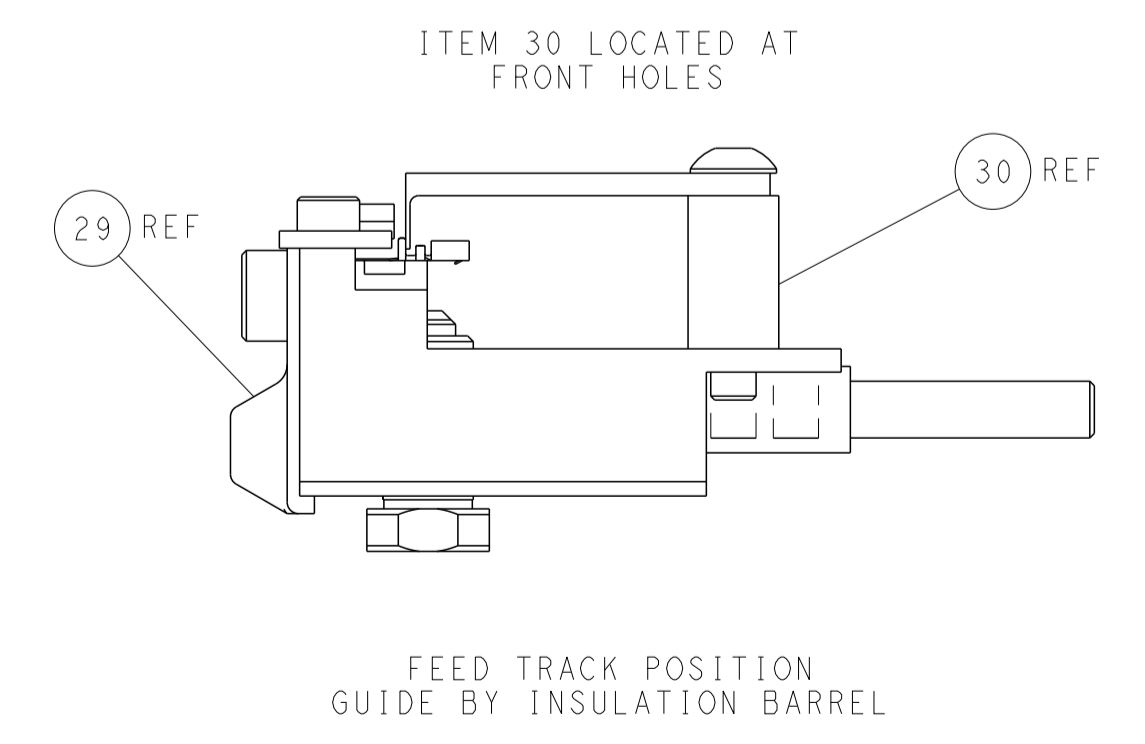
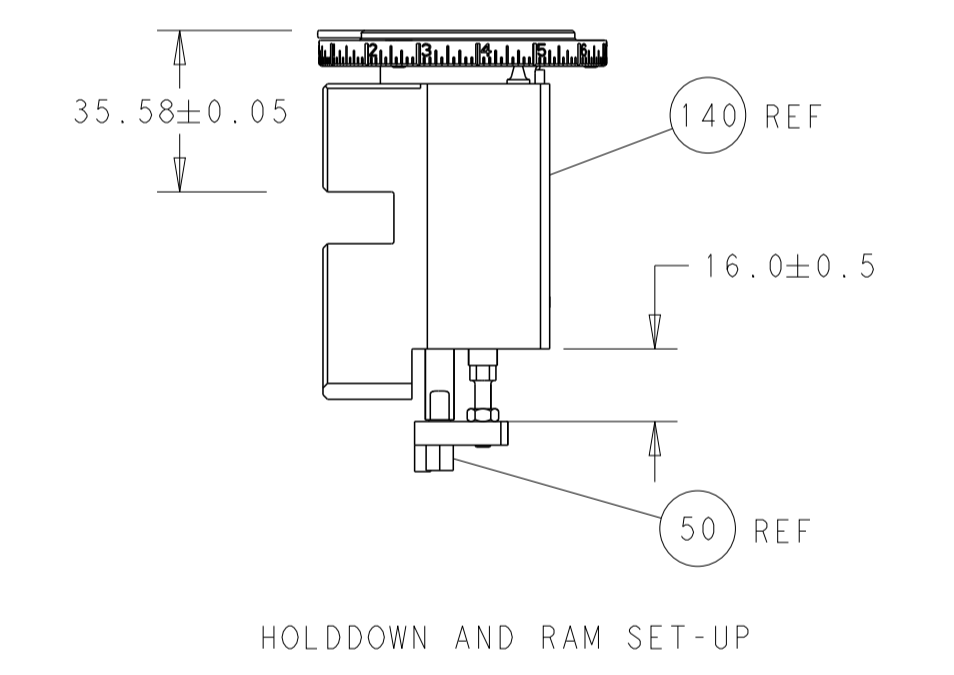
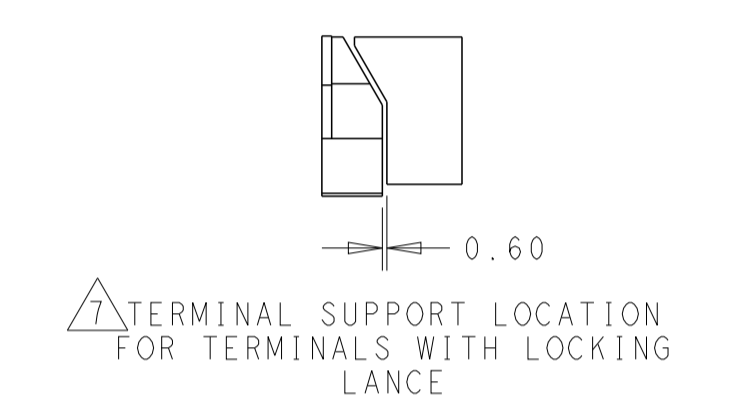
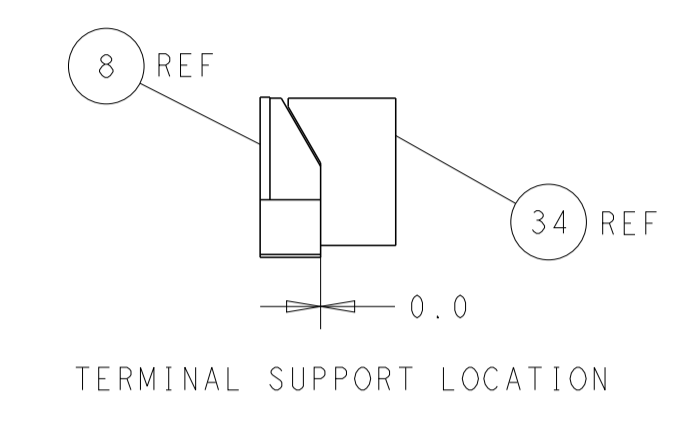
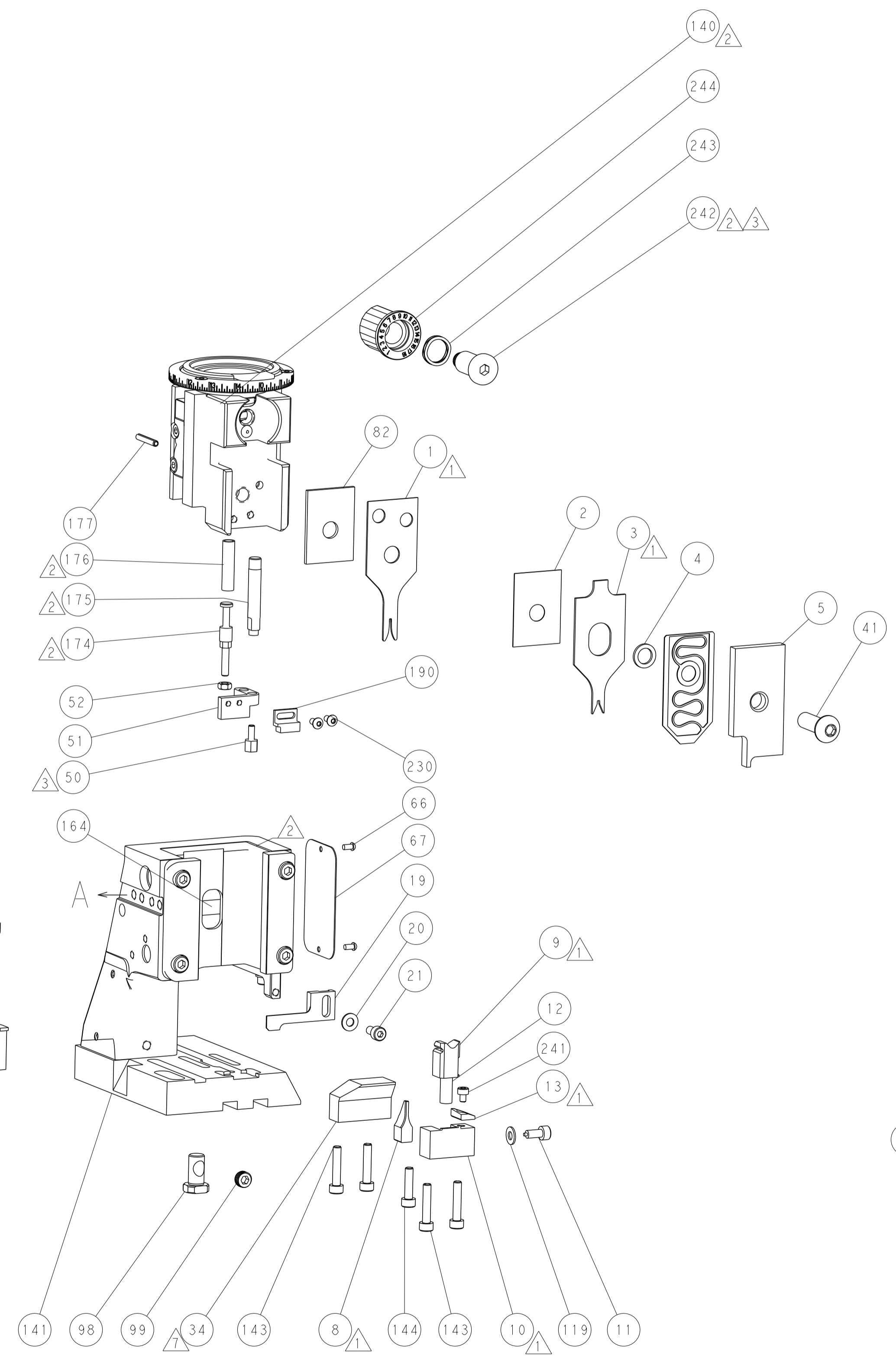
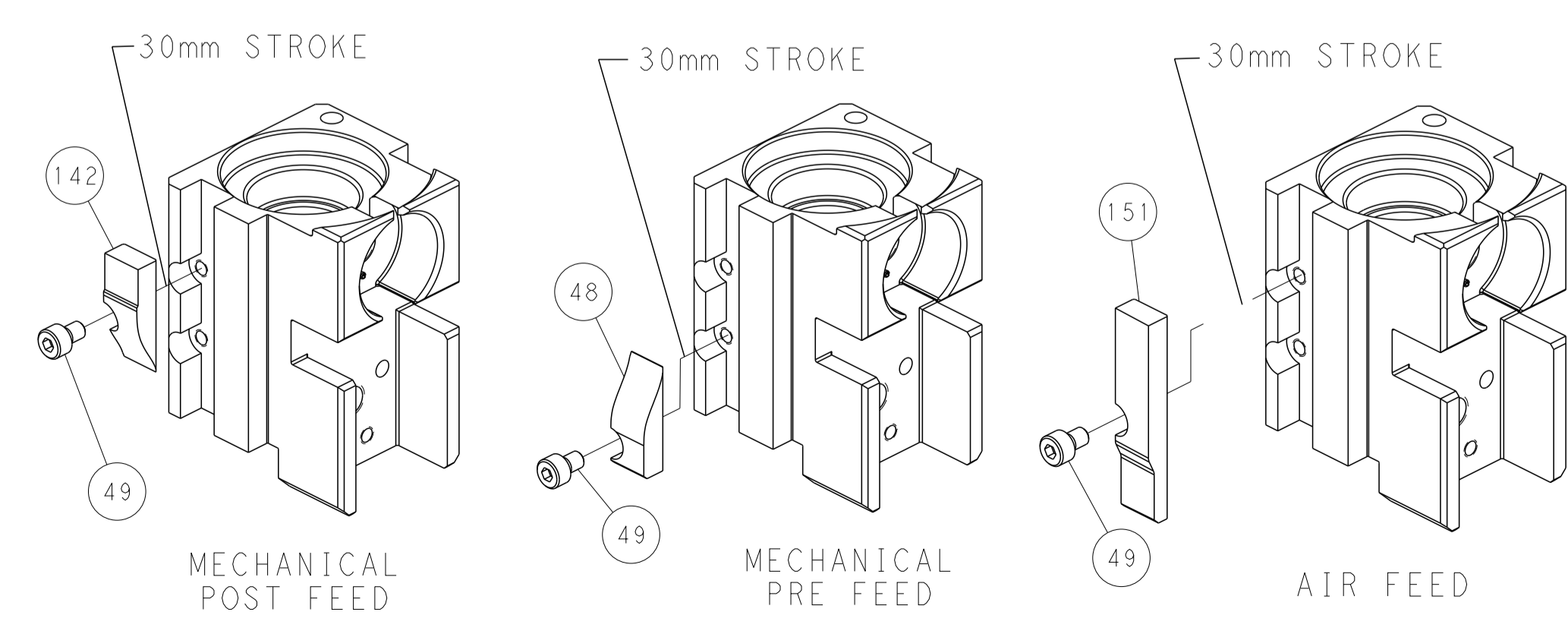

**PACIFIC VERSION**  
 Shown on sheets 3 of 4 & 4 of 4  
 (Atlantic version shown on sheets 1 of 4 & 2 of 4)

DIMENSIONS: mm 		TOLERANCES UNLESS OTHERWISE SPECIFIED: 0 PLC ± 1 PLC ± 2 PLC ± 3 PLC ± 4 PLC ± ANGLES ± FINISH		DWN X_ZHAO 11MAY2012 CHK T_ELBIN 11MAY2012 APVD S_XI 11MAY2012 PRODUCT SPEC APPLICATION SPEC WEIGHT Customer Accessible Production Drawing		NAME Ocean Side Feed Applicator SIZE CAGE CODE DRAWING NO. RESTRICTED TO A1 00779 C=2151430 SCALE 1:2 SHEET 4 OF 4 REV G	
--------------------	--	---	--	--	--	---	--