

10 9 8 7 6 5 4 3 2 1

NOTES:

1. MATERIALS:

HOUSING - LIQUID CRYSTAL POLYMER (LCP),
UL94 V-0, COLOR: BLACK.

TERMINAL - COPPER ALLOY

2. FINISH: SELECTIVE GOLD ON MATING SURFACE,
MATTE TIN ON TAILS; NICKEL UNDERPLATE.

3. THIS PART CONFORMS TO PRODUCT SPECIFICATION
PS-74031-999.

4. SINGLE ROW ASSEMBLY PACKAGED PER PK-70873-0876.

5. MATES WITH 74026 SERIES DAUGHTERCARD POWER ASSEMBLY.

6. MATING INTERFACE MEASURED FROM BOTTOM OF HOUSING.

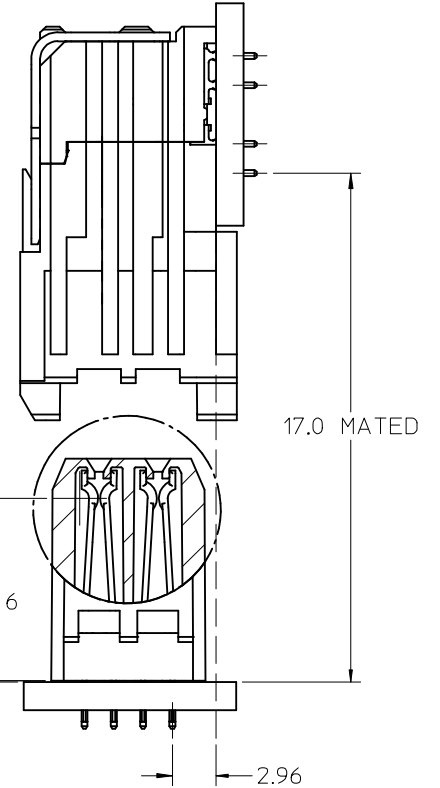
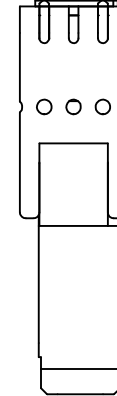
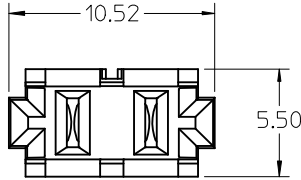

LEAD-FREE
PLATING

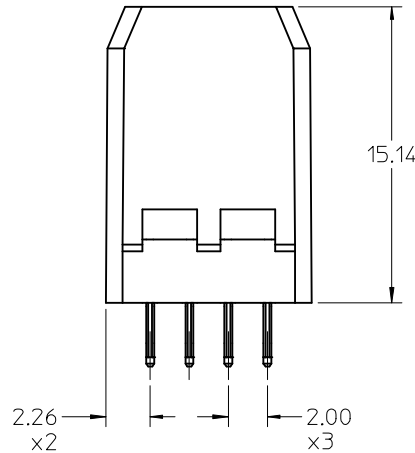
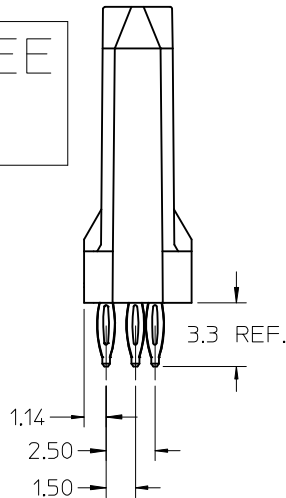

MOLEX P/N	GOLD THICKNESS (MINIMUM)	TAIL PLATING
74029-6000	30 MICROINCHES	MATTE TIN
74029-6050	50 MICROINCHES	

ADD LEADED P/N	EC NO: UCP2013-0146	2012/07/12
DRW:SVANG01	CHKD:WOLFE	2012/07/12
APPR:SMILLER		2012/08/06

REV	DESCRIPTION	QUALITY SYMBOLS
F		$\nabla = 0$
E		$\nabla = 0$
D		$\nabla = 0$

GENERAL TOLERANCES (UNLESS SPECIFIED)	
mm	INCH
4 PLACES	\pm ---
3 PLACES	\pm ---
2 PLACES	± 0.25
1 PLACE	± 0.38
0 PLACE	\pm
ANGULAR $\pm 1/2^\circ$	
DRAFT WHERE APPLICABLE MUST REMAIN WITHIN DIMENSIONS	

DIMENSION STYLE	
MM ONLY	
DRAWN BY	DATE
ELO	2003/07/14
CHECKED BY	DATE
STANFORD	2003/07/17
APPROVED BY	DATE
BIXLER	2003/07/21
MATERIAL NO.	
SEE TABLE	

SCALE	DESIGN UNITS	THIRD ANGLE PROJECTION
4:1	METRIC	\odot \square
TITLE		
VHDM/HSD POWER 6 ROW BACKPLANE SALES DRAWING		
molex		
DOCUMENT NO.	SHEET NO.	
SD-74029-011	1 OF 3	

9 8 7 6 5 4 3 2 1

NOTES:

1. THIS DESIGN INTENDED AS OPTION TO HAVING TWO SINGLE ROW MODULES NEXT TO EACH OTHER.
2. FINISH: SELECTIVE GOLD ON MATING SURFACE; TIN/LEAD OR MATTE TIN ON TAILS; NICKEL UNDERPLATE.
3. DUAL ROW ASSEMBLIES PACKED PER PK-70873-545.

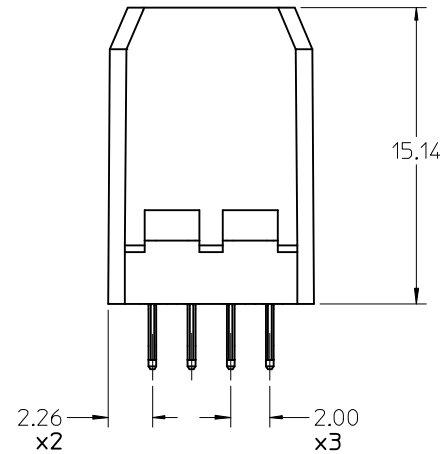
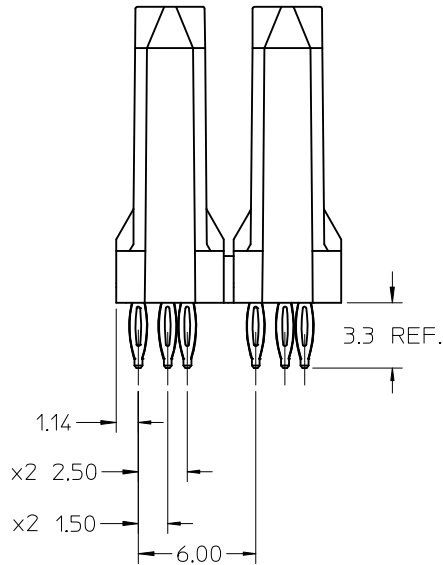
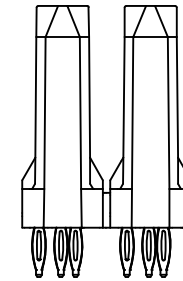
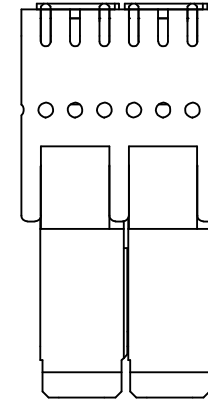
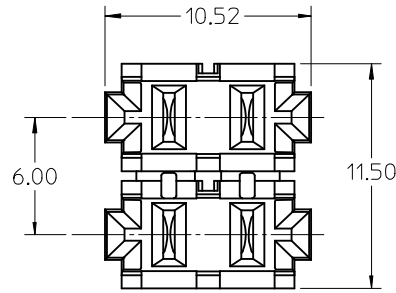

DUAL ROW ASSEMBLY

MOLEX P/N	GOLD THICKNESS (MINIMUM)	TAIL PLATING
74029-6002	30 MICROINCHES	MATTE TIN
74029-6052	50 MICROINCHES	
74029-6902	30 MICROINCHES	TIN/LEAD
74029-6952	50 MICROINCHES	

SEE SHEET 1 EC NO: UCP2013-0146 DRWN:SVANG01 2012/07/12 CHKD:MWOLF 2012/07/12 APPR:SMILLER 2012/08/06	QUALITY SYMBOLS	GENERAL TOLERANCES (UNLESS SPECIFIED)	DIMENSION STYLE	SCALE	DESIGN UNITS	THIRD ANGLE PROJECTION
	∇=0 ∇=0 ∇=0	mm	MM ONLY	4:1	METRIC	VHDM/HSD POWER 6 ROW BACKPLANE SALES DRAWING molex
		INCH				
		4 PLACES ± --- ± ---	DRAWN BY	DATE	TITLE	
3 PLACES ± --- ± ---		ELO	2003/07/14			
	2 PLACES ± 0.25 ± ---	CHECKED BY	DATE			
	1 PLACE ± 0.38 ± ---	STANFORD	2003/07/17			
	0 PLACE ± ±	APPROVED BY	DATE			
		BIXLER	2003/07/21			
	ANGULAR ± 1/2°	MATERIAL NO.		DOCUMENT NO.		SHEET NO.
	DRAFT WHERE APPLICABLE MUST REMAIN WITHIN DIMENSIONS	SEE TABLE		SD-74029-011		2 OF 3
		SIZE B	THIS DRAWING CONTAINS INFORMATION THAT IS PROPRIETARY TO MOLEX INCORPORATED AND SHOULD NOT BE USED WITHOUT WRITTEN PERMISSION			

BOARD LAYOUTS: 1.8 mm MIN. BOARD THICKNESS

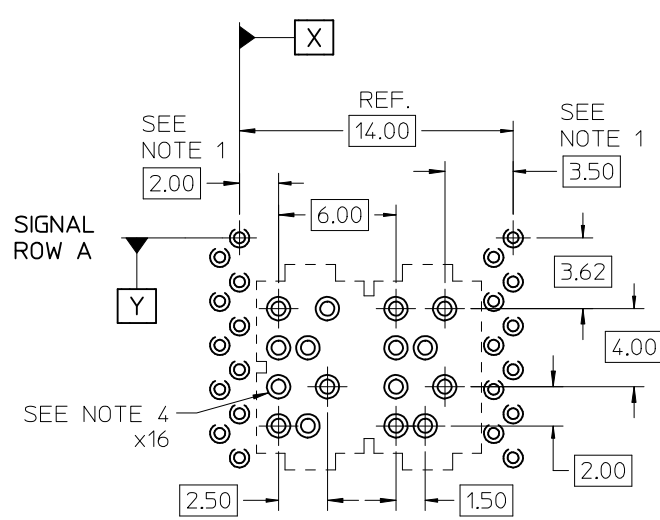

VHDM DUAL ROW POWER

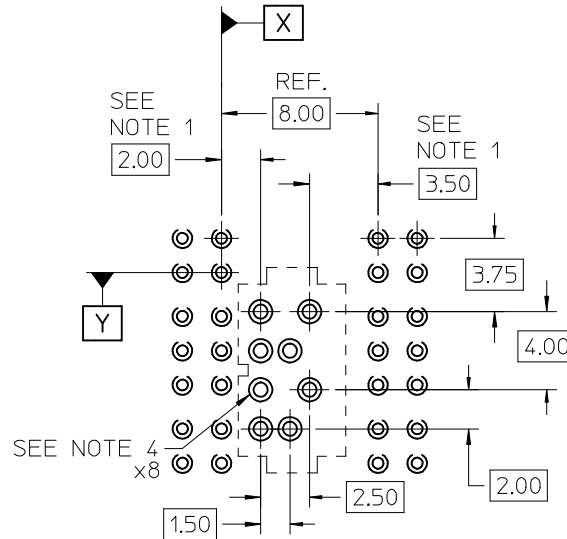

VHDM-HSD SINGLE ROW POWER

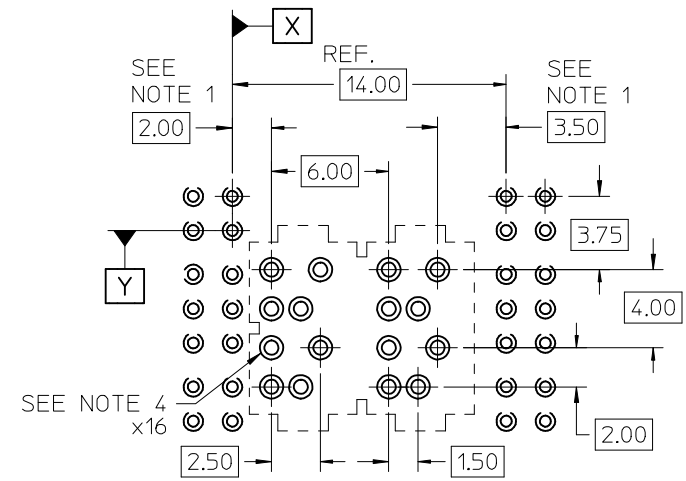

VHDM-HSD DUAL ROW POWER

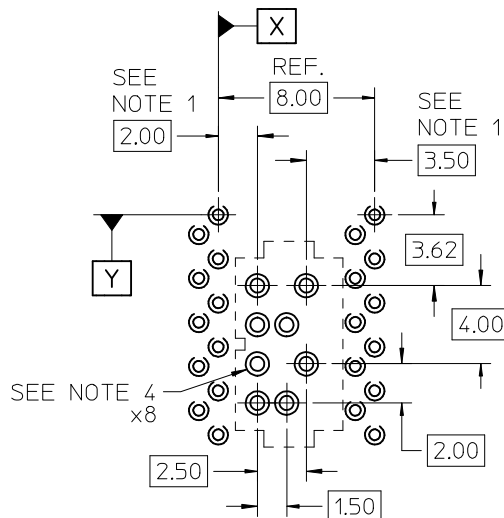

VHDM SINGLE ROW POWER

NOTES:

1. ADDITIONAL SPACING CAN BE ADDED IN MULTIPLES OF 2.0 mm AS REQUIRED. FOR EACH ADDITIONAL SINGLE ROW POWER, ADD 6.00 mm.
2. SIGNAL ROW A IS IN LINE WITH DATUM Y IN ALL FOUR LAYOUTS.
3. FOUR HOLES ARE USED PER POWER CONTACT.
4. EACH POWER HOLE TO BE MANUFACTURED AS FOLLOWS:

- Ø0.725±0.075 PLATED THROUGH HOLE
- Ø1.20 PAD
- Ø0.838 DRILL

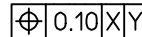

SEE SHEET 1 EC NO: UCP2013-0146 IDRWN: SVANG01 2012/07/12 CHKD: MWOLF 2012/07/12 APPR: SMILLER 2012/08/06	DESCRIPTION REV	QUALITY SYMBOLS	GENERAL TOLERANCES (UNLESS SPECIFIED)	DIMENSION STYLE	SCALE	DESIGN UNITS	THIRD ANGLE PROJECTION		
		$\nabla Z=0$ $\nabla Z=0$ $\nabla Z=0$	mm INCH 4 PLACES ± --- ± --- 3 PLACES ± --- ± --- 2 PLACES ± 0.25 ± --- 1 PLACE ± 0.38 ± --- 0 PLACE ± ±	MM ONLY	4:1	METRIC	DRAWN BY DATE ELO 2003/07/14 CHECKED BY DATE STANFORD 2003/07/17 APPROVED BY DATE BIXLER 2003/07/21	TITLE	VHDM/HSD POWER 6 ROW BACKPLANE SALES DRAWING
			ANGULAR ±1/2°	MATERIAL NO.	DOCUMENT NO.	SD-74029-011		SHEET NO.	3 OF 3
		DRAFT WHERE APPLICABLE MUST REMAIN WITHIN DIMENSIONS	SIZE B	SEE TABLE	THIS DRAWING CONTAINS INFORMATION THAT IS PROPRIETARY TO MOLEX INCORPORATED AND SHOULD NOT BE USED WITHOUT WRITTEN PERMISSION				