

QLSP04RBU
(High Power color 3030 LEDs)



Product Outline:

This is the high power LED with reflector type. EMC 3030 Single color is a surface-mount LED which with heat sink to enhance operating performance. With special binning technology, these LEDs are ideal for architecture lighting and special lighting needs.

Features:

- Royal Blue Color
- High brightness output @ 350mA,
- High driving current to 1000mA
- Package Dimension = 3.2mmX3.0mmX0.6mm
- ESD protection up to 8KV
- RoHS compliant
- Custom Bin available upon special request

Application:

- Warning lamp
- Decoration lamp
- Architecture Lighting
- Garden Lighting

Compliance and Certification:



Mechanical Property: (Dimension)

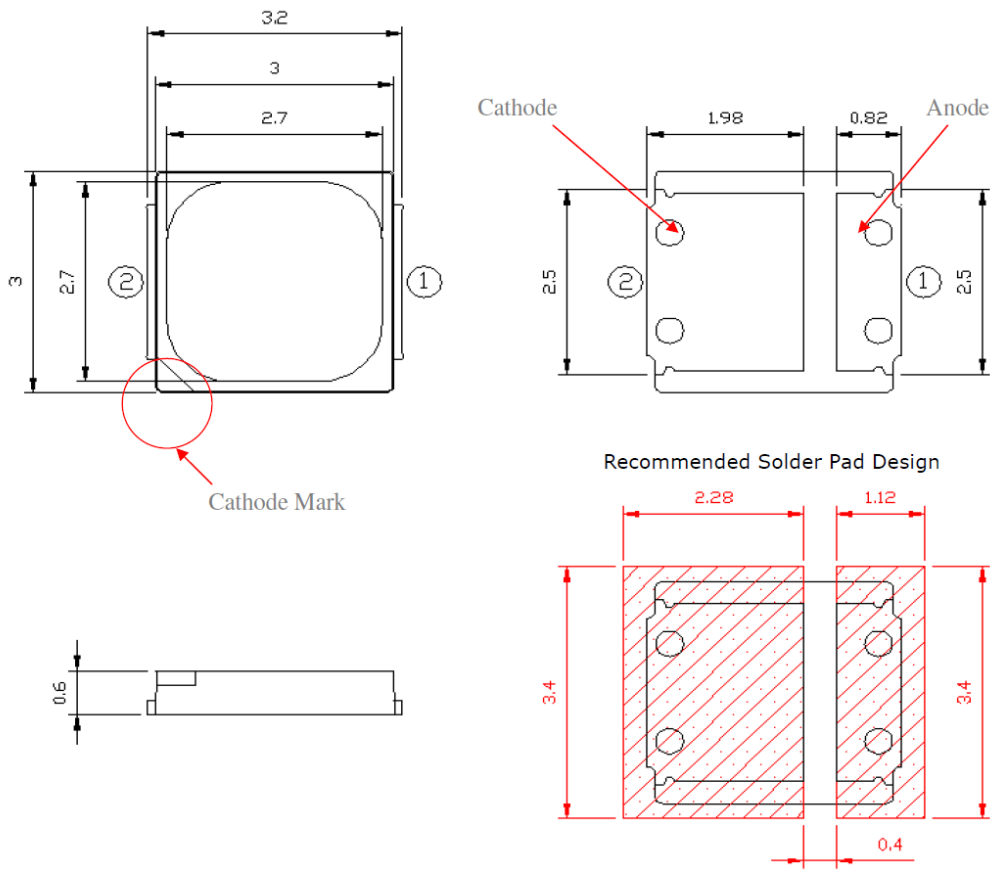

- * All dimensions are in millimeters,
- * Tolerances are $\pm 0.10\text{mm}$.

Recommended Solder footprint:

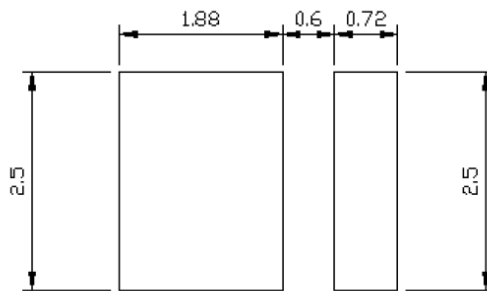

- * All dimensions are in millimeters.
- * The LEDs is designed to be reflow soldered on to a PCB. IF dip soldered that QL cannot guarantee its reliability.
- * Reflow soldering must not be performed more than twice.



Characteristics

■ Absolute Maximum Ratings

(Ta=25°C)

Parameter	Symbol	Rating	Unit
DC Forward Current	I _f	1000	mA
Leakage Current	I _r	1.0	μA
Power Dissipation	P _d	3.3	W
Pulse Forward Current	I _{fp}	1000	mA
LED Junction Temperature	T _J	125	°C
Storage Temperature	T _{stg}	-40 ~ 100	°C
Operation Temperature	T _{opr}	-40 ~ 85	°C
Soldering Temperature	T _{sol}	260 < 10 sec	°C
ESD Sensitivity(HBM)		8	KV
Thermal Resistance	R _{th}	10	°CW

- (1) Proper current rating must be observed to maintain junction temperature below maximum at all time
 (2) IFP Condition: Duty 1/10, Pulse within 10msec

■ Electrical / Optical Characteristic

(Ta=25 oC)

Product	Color	I _F (mA)	V _F (V)		Wavelength nm	Luminous Flux(lm)/mW		Refer @ 700mA Typ.(lm)/mW
			Typ.	max		min	typ.	
QLSP04RBU	Royal Blue	350	3.2	3.5	450~460	18	20	33



■ Groups

Dominant Wavelength

Wd (nm)			
Color	Code name	Min.	Max.
Royal Blue	DA	450	455
	DB	455	460

Measurement tolerance is +/- 1nm

Forward Voltage (V_F) Bin:

VF Rank			
Color	Code name	Low	High
Royal Blue	01	2.8	3.0
	23	3.0	3.2
	45	3.2	3.4
	67	3.4	3.6

The forward voltage tolerance is ± 0.1V

Luminous Flux Bin:

Rank @350mA (lm)			
Color	Code name	Low	High
Royal Blue	QJ9	20	30
	QN9	30	40

luminous flux tolerance is ± 7%



Characteristic Curves

(1) Color Spectrum

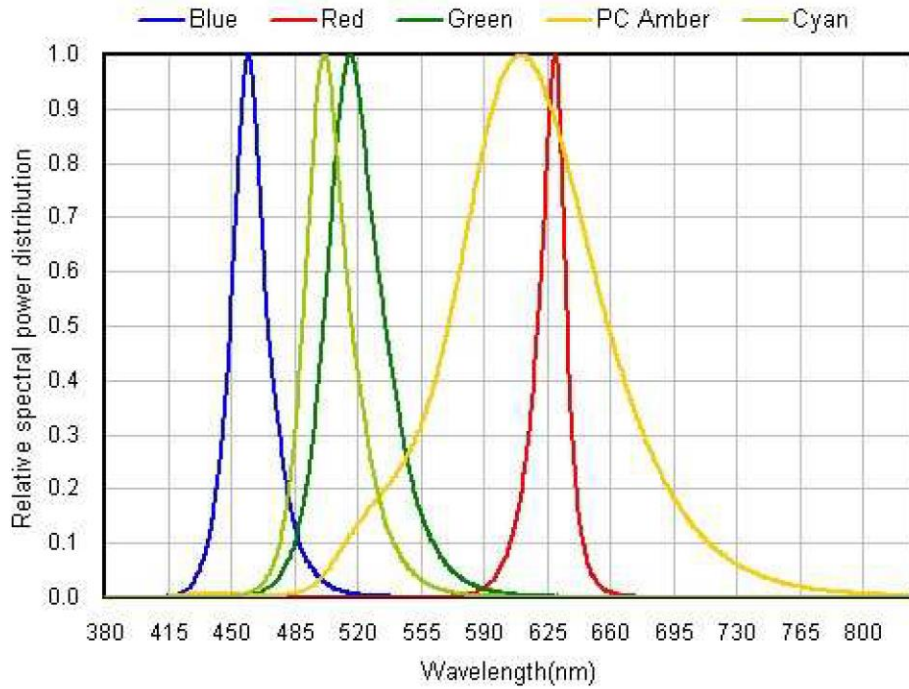

(2). Typical Representative Spatial Radiation Pattern

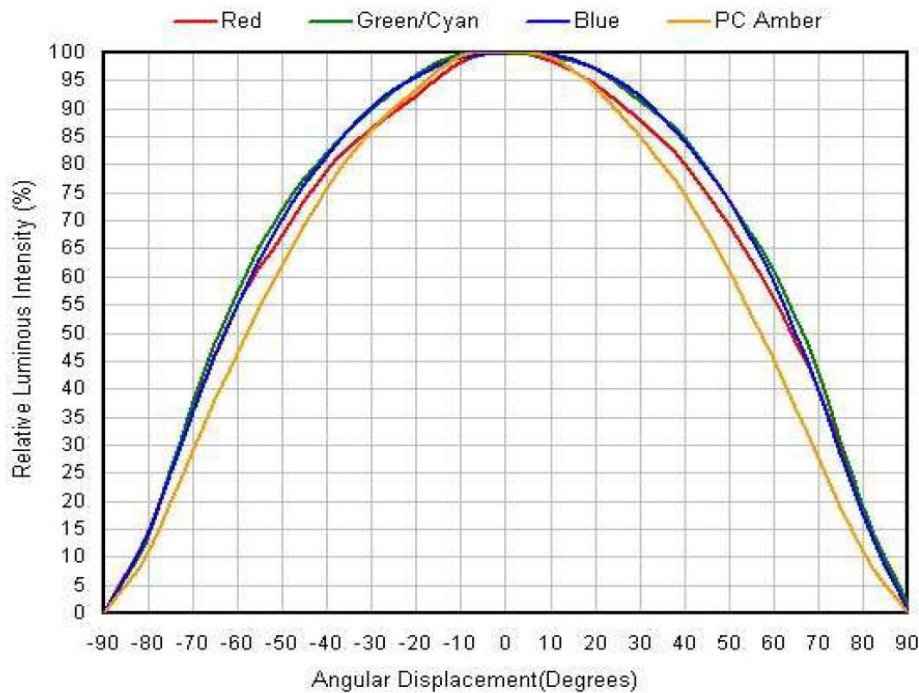

(3). Forward Current Characteristics

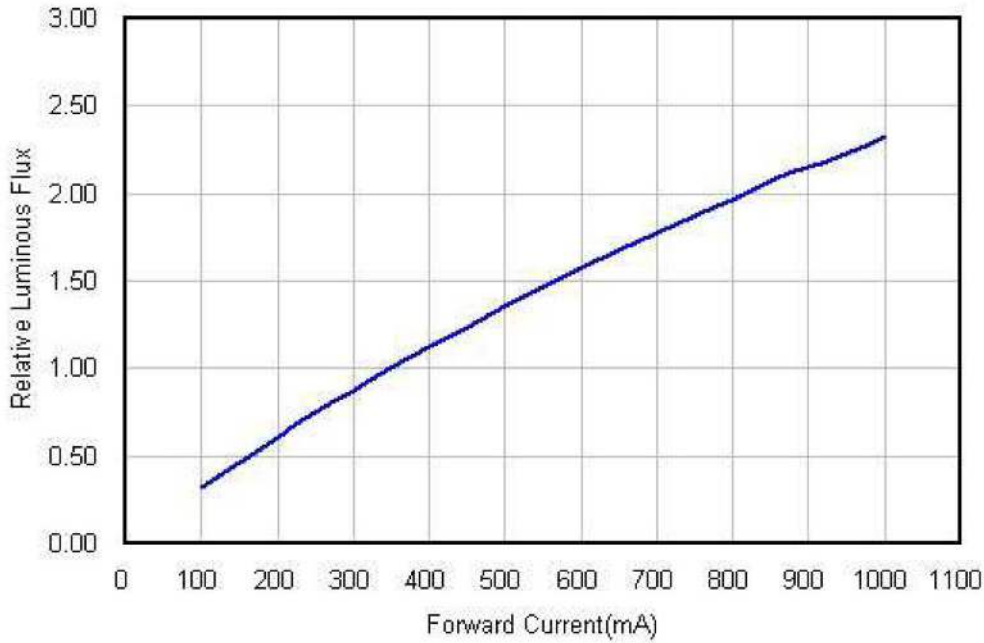

(4). Forward Current vs Forward Voltage

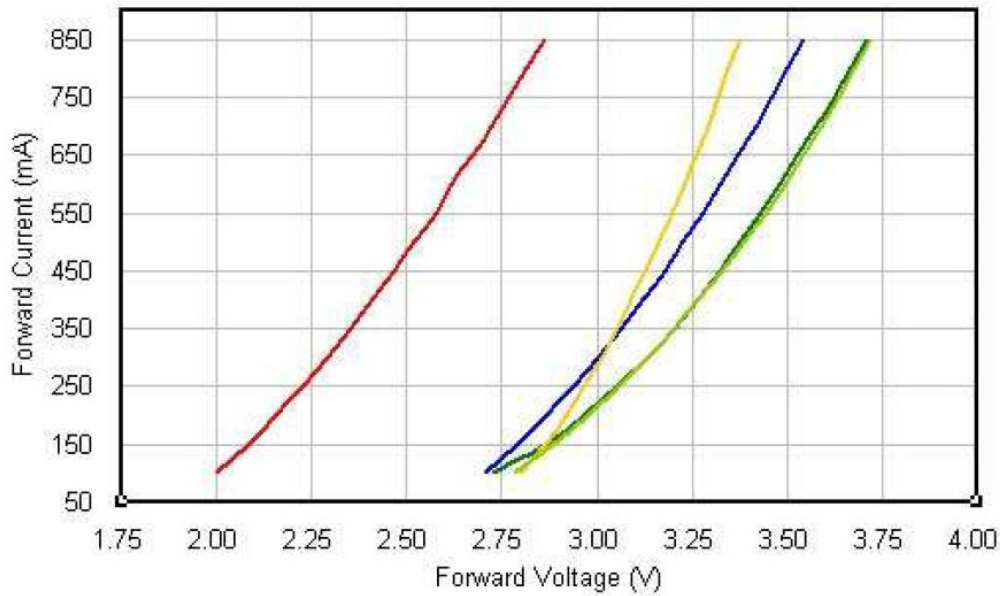

■ Reliability test:

No	Item	Condition	Time/Cycle	Sample size
1	Steady State Operating Life of Room Temperature	25°C Operating	1000 Hrs	20 pcs
2	Steady State Operating Life of Low Temperature -40°C	-40°C Operating	1000 Hrs	20 pcs
3	Steady State Operating Life of Low Temperature 60°C	60°C Operating	1000 Hrs	20 pcs
4	Steady State Operating Life of Low Temperature 85°C	85°C Operating	1000 Hrs	20 pcs
5	Low temperature storage -40°C	-40°C Storage	1000 Hrs	20 pcs
6	High temperature storage 100°C	100°C Storage	1000 Hrs	20 pcs
7	Steady State Operating Life of High Humidity Heat 60°C 90%	60°C/90% Operating	1000 Hrs	20 pcs
8	Steady State Pulse Operating Life Condition	25°C 10Hz duty=1/10 Operating	200 Cycle	20 pcs
9	Resistance to soldering heat on PCB (JEDEC MSL3)	pre-store@60°C, 60%RH for 52hrs Tslid max.=260 10sec	3 Times	20 pcs
10	Heat Cycle Test (JEDEC MRC)	25°C ~65°C ~-10°C, 90%RH, 24hr/1cycle	10 Cycle	20 pcs
11	Thermal shock	-40°C / 20minr~ 5minr~100°C /20min	300 Cycle	20 pcs

■ Judgment Criteria:

Item	Symbol	Test Condition	Judgment Criteria
Forward Voltage	Vf	350 mA	$\Delta Vf < 10\%$
Luminous Flux	Iv	350 mA	$\Delta Iv < 30\%$



Solder Profile:

-The recommended reflow soldering profile is as follows (temperatures indicated are as measured on the surface of the LED resin):

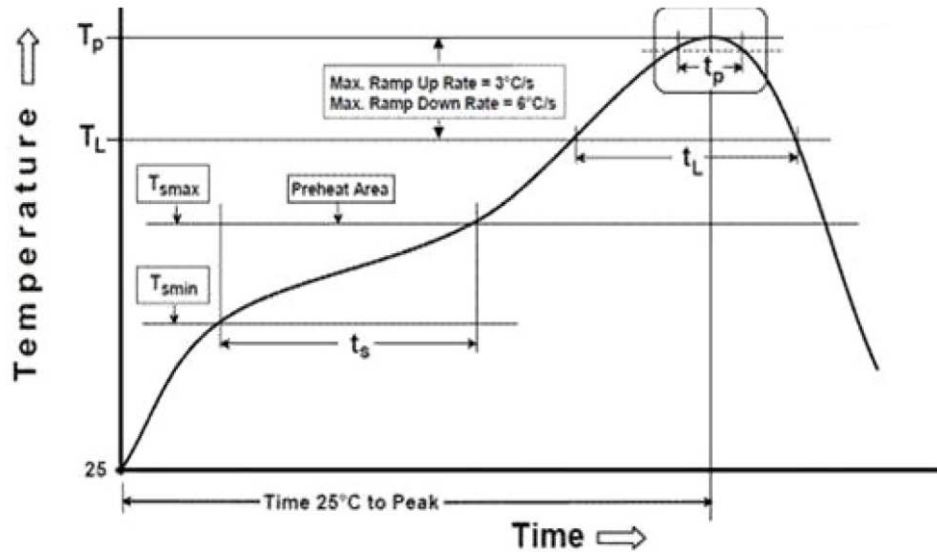

Profile Feature	Sn-Pb Eutectic Assembly	Pb-Free Assembly
Temperature Min(T_{smin})	100°C	150°C
Temperature Max(T_{smax})	150°C	200°C
Time(t_a) from (T_{smin} to T_{smax})	60-120 seconds	60-120 seconds
Ramp-up rate(T_L to T_p)	3°C/second max.	3°C/second max.
Liquidous Temperature(T_L)	183°C	217°C
Time(t_L) maintained above T_L	60-150 seconds	60-150 seconds
Peak package body temperature(T_p)	235°C	260°C
Time within 5°C of Actual Peak temperature (t_p)	20seconds*	30 seconds*
Ramp-down rate(T_p to T_L)	6°C/second max.	6°C/second max.
Time 25°C to peak temperature	6 minutes max.	8 minutes max.
* Tolerance for peak profile temperature (T_p) is defined as a supplier minimum and a user maximum.		



Taping & Packing:

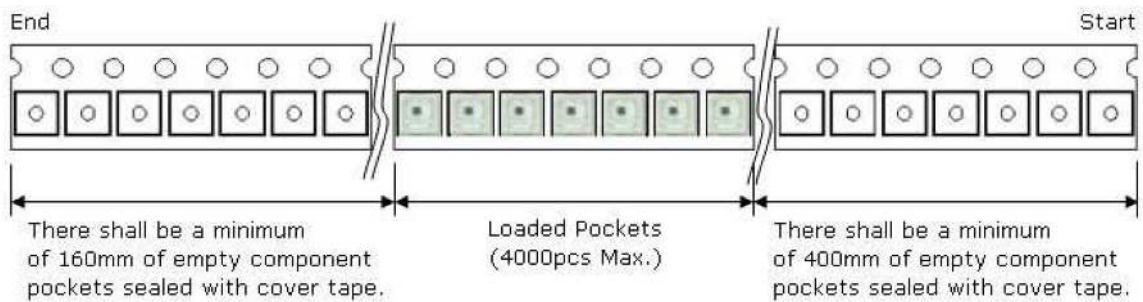
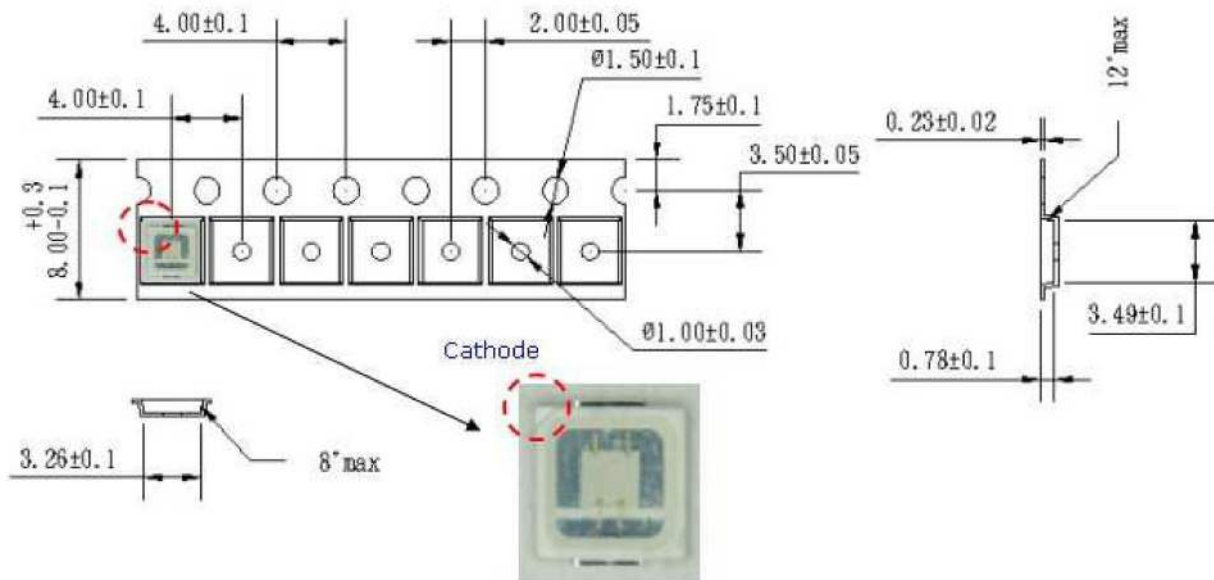

Unit : mm



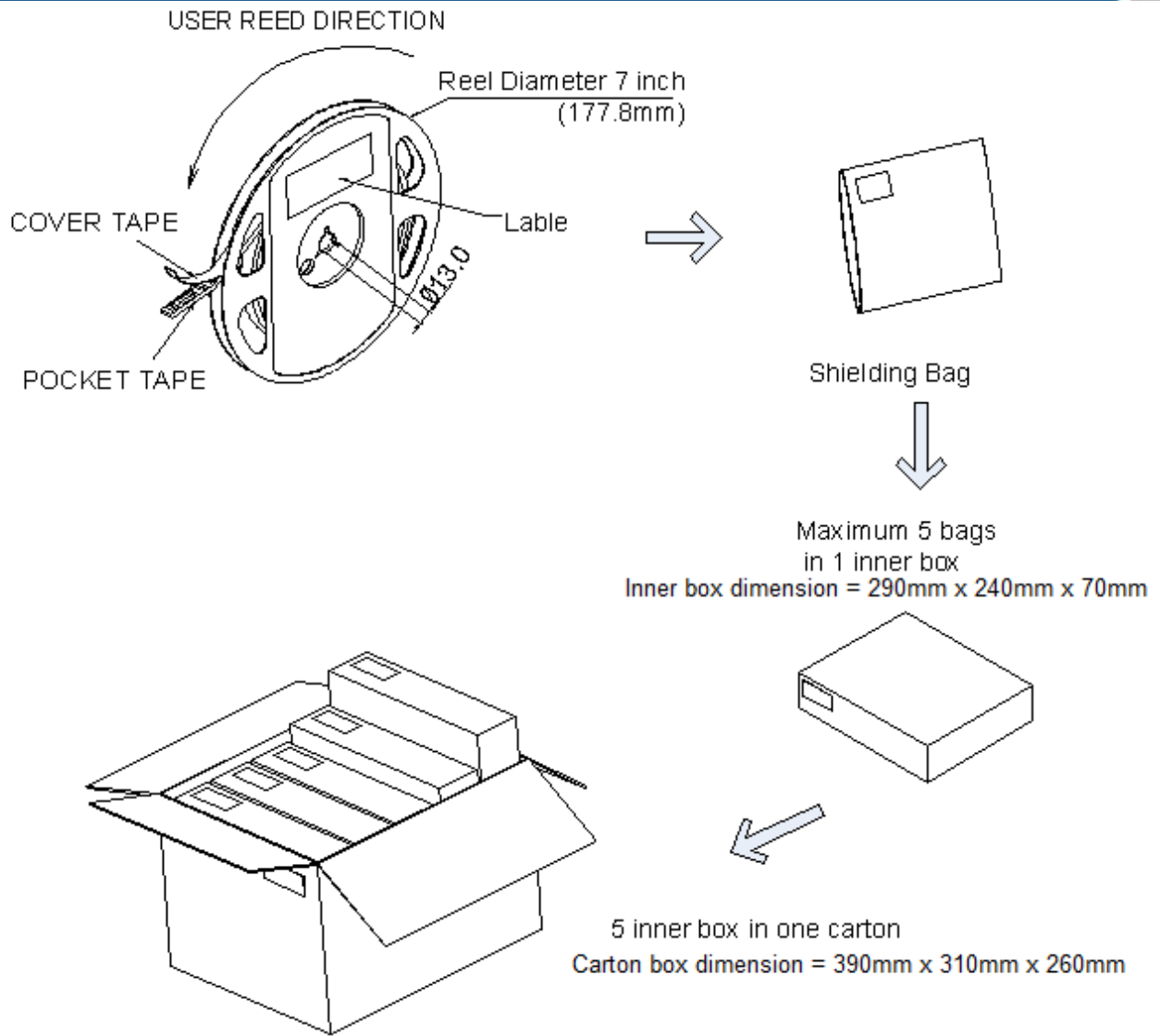

Labeling

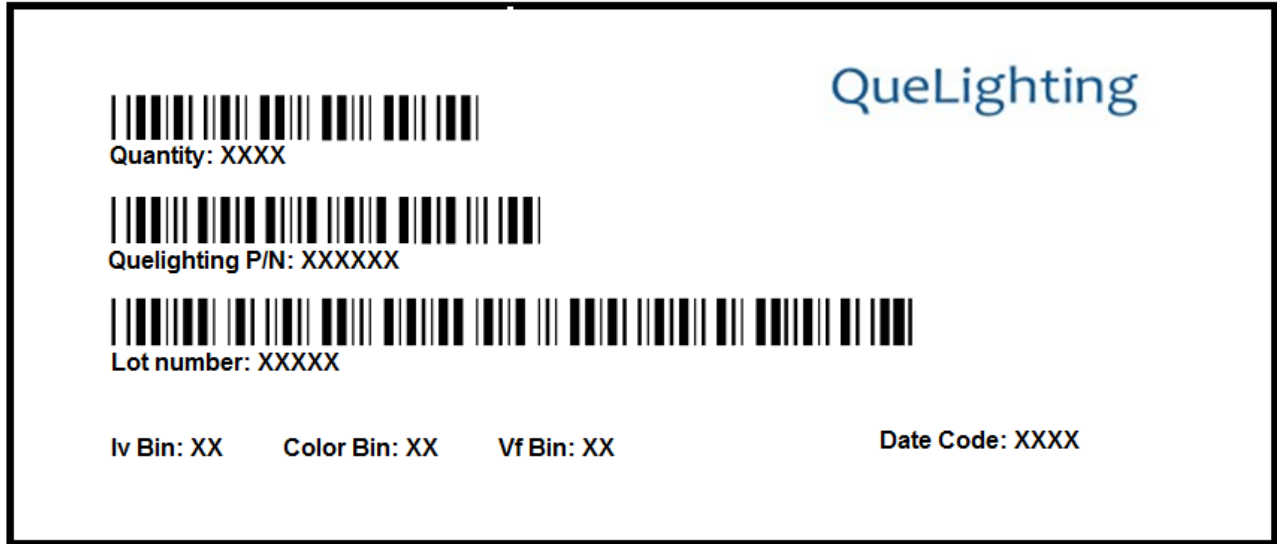

Ordering Information:

Part #	Multiple Quantities	Quantity per Reel
QLSP04RBU		1000,2000 pcs



Revision History:

Revision Date:	Changes:	Version #:
03-30-2017	Initial release	1.0
08-01-2018	Add color on Royal Blue, Cyan Green, Deep Red, Cherry Red	1.1

