

THIS DOCUMENT IS THE PROPERTY OF APDM COMPONENTS AND SHALL NOT BE COPIED, REPRODUCED, DISCLOSED OR USED AS THE BASIS FOR MANUFACTURING OR SALE WITHOUT PERMISSION OF A DULY AUTHORIZED REPRESENTATIVE OF APDM COMPONENTS INC.

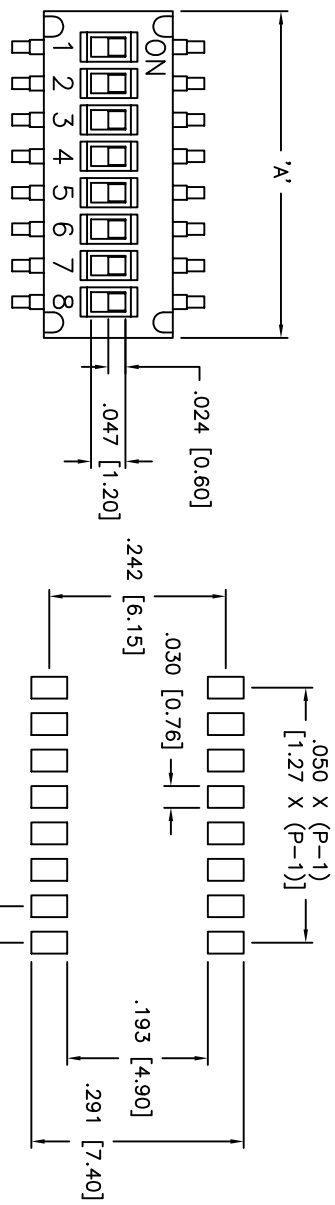

P.C. LAYOUT
UNLESS OTHERWISE SPECIFIED
P.C. TOLERANCES ARE ±.002 [0.05]

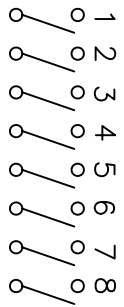
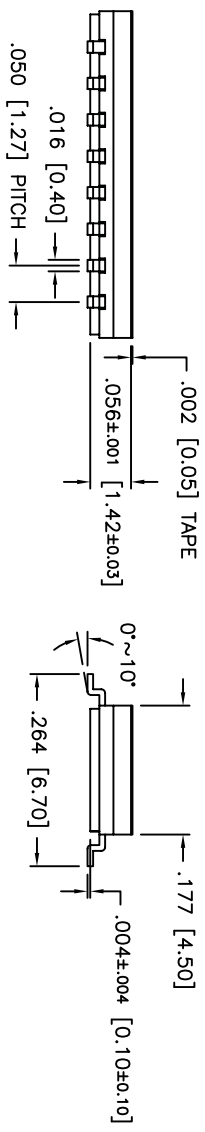

CIRCUIT DIAGRAM

MODEL NUMBER	NO. OF POSITIONS	DIMENSION 'A'
NHDS02	2	.148 [3.77]
NHDS04	4	.248 [6.31]
NHDS06	6	.348 [8.85]
NHDS08	8	.448 [11.39]
NHDS10	10	.548 [13.93]

PROD. NO.: NHDS*****
 PROD. SERIES: _____
 NUMBER OF POSITIONS: _____
 PAKAGING: □ = TUBE
 T/R = TAPE & REEL
 SEALING: □ = REGULAR
 T = TOP TAPE SEAL
 PLATING: □ = IN ON POSITION
 F = IN OFF POSITION
 □ = 3u" GOLD MIN
 A = 10u" GOLD MIN.

DESCRIPTION: SURFACE MOUNT DIP SWITCH
 WITH TAPE SEAL OPTION.
 SPECIFICATIONS:

SWITCHING RATING: 25mA, 24VDC.
 NON-SWITCHING RATING: 100mA, 50VDC.
 CONTACT RESISTANCE: 100 MOHMS MAX
 DIELECTRIC STRENGTH: 300VAC for 1 MINUTE.
 INSULATION RESISTANCE: 100MOHMS MIN. AT 500VDC
 CAPACITANCE: 5PF MAX.
 OPERATING FORCE: 500 gf MAX.
 STROKE: 0.6mm
 OPERATING TEMP: -40° to 85° C.
 STORAGE TEMP: -40° to 85° C.
 ELECTRICAL LIFE: 1,000 CYCLES.
 MECHANICAL LIFE: 1,000 OPERATIONS.
 CIRCUIT: 1 POLE 1 THROW.
 VIBRATION TEST: PASSES METHOD 201A. MIL-STD-202F.
 SHOCK TEST: 50g PER METHOD 213B. MIL-STD-202F.

MATERIALS:
 BASE & COVER: UL94V-0 NYLON THERMOPLASTIC
 COLOR, BLACK
 ACTUATOR: LCP THERMOPLASTIC.
 COLOR, WHITE
 CONTACT: COPPER ALLOY WITH GOLD PLATING OVER NICKEL
 TERMINAL: BRASS WITH GOLD PLATING
 TAPE: KAPTON
 SOLDERING:
 VAPOR PHASE & IR REFLOW CAN BE APPLIED.
 240C MAX.

DATE	SYM	REVISION RECORD	DWNL	CK
10/05	A	ECO# 484	CD	

QA INSPECT: _____

DESIGNER'S ORIGINAL DIMENSION

TOLERANCES (UNLESS OTHERWISE SPECIFIED)

XXX±.02[0.05]
 XXX±.0008[0.20]
 XXX±.0008[0.02]
 ANGLE = 30.5°

APDM
 63 Neck Rd.
 Hendersonville, NC 27535
 Phone: 704-372-5554
 Fax: 704-372-5554

DRN: PJD
 BR: _____
 OR: _____

TITLE: NHDS**

DO NOT SCALE

DATE: 12/28/04

DRAWING NO.: B7627

REV: A