



TW1010/TW1012 Embedded GPS L1 Antenna

The TW1010/TW1012 is low cost, high gain, high performance, embedded GPS L1 antenna, specially designed for OEM industrial, military, precision positioning and timing applications.

The TW1010/TW1012 features a precisely tuned single feed ceramic patch element. It has a two stage Low Noise Amplifier (LNA) with a mid-section SAW. An optional tight pre-filter is available with part number TW1012 to protect against saturation by high level sub-harmonics and L-Band signals.

The TW1010/TW1012 covers the GPS L1 and SBAS (WAAS /EGNOS/MSAS) frequency band (1572.5 to 1578 MHz), and it offers great circular polarized signal reception, multipath rejection and out of band signal rejection.

The TW1010/TW1012 has a built-in 35mm circular ground plane that can be augmented with host system ground surfaces. Patch Elements are susceptible to detuning by the local environment. Tallysman offers custom services to assist with integration of OEM modules into an end user solution.

Custom cable lengths and connectors are available.

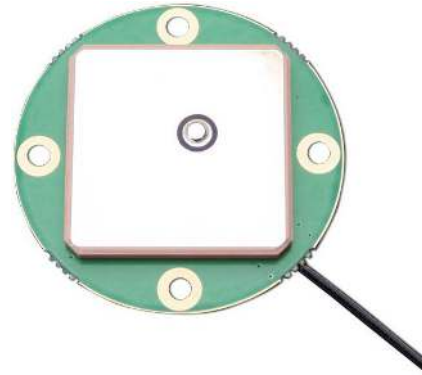

TW1010/TW1012 Dimensions with RG174 cable (mm)

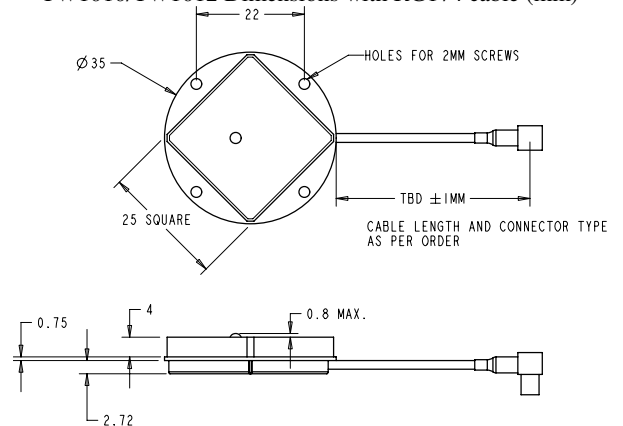

Applications

- High Accuracy & Mission Critical GPS
- Precision Agriculture, Mining & Construction
- Military & Security
- Avionics
- Law Enforcement & Public Safety
- Fleet Management & Asset Tracking

Features

- Very low noise LNA: 1 dB (TW1010).
- Great axial ratio: <4dB at Zenith
- High rejection SAW filter
- LNA gain: 28 dB typ (TW1010).
- Low current: 9 mA typ.
- ESD circuit protection: 15 KV
- Wide Supply voltage: fixed 2.5V to 16V

Benefits

- Low Profile: 7.25mm
- Great multipath rejection
- Increase system accuracy
- Excellent signal to noise ratio
- Great out of band signal rejection
- Compact form factor
- RoHS compliant



TW1010/TW1012 Embedded GPS L1 Antenna

Specifications At; Vcc = 3V, over full bandwidth, T=25°C

Antenna

Architecture	Custom single-feed ceramic patch
Polarization	RHCP
Antenna Gain (70mm ground plane)	4 dBic at 90°
Axial Ratio	4 dB at 90°, 6dB at 20°
Frequency/Bandwidth (-10dB Return Loss)	1575.42MHz +/- 10MHz

Electrical

Architecture	TW1010 TW1012	LNA stage 1 -> SAW filter-> LNA stage 2 SAW Prefilter ->LNA stage 1 -> SAW filter-> LNA stage 2
Gain (1575.42 to 1606 MHz)		26dB min., TW1010; 24dB min, TW1012,
Filtered LNA Frequency Bandwidth (3dB)		1575.42MHz +/- 10MHz
Out-of-Band Rejection		TW1010: <1500MHz >35dB. TW1012: >70dB. TW1010: <1550MHz >25dB. TW1012: >55dB. TW1010: >1650MHz >35dB. TW1012: >65dB.
VSWR (at LNA output)		<1.5:1 typ. 1.8:1 max.
Noise Figure		TW1010:1 dB typ. TW1012: 3.5dB typ.
Supply Voltage Range (over coaxial cable)		+2.5VDC to 16VDC nominal
Supply Current		9 mA typ,
ESD Circuit protection		15KV air discharge

Mechanicals & Environmental

Mechanical Size	35mm dia. x 7.5mm
Cable	1.48mm OD,
Operating Temp. Range	-40°C to +85°C
Weight	30 g
Attachment Method	Adhesive or screw mount
Environmental	RoHS compliant
Shock	Vertical axis: 50G, other axes: 30G
Vibration	3 axis, sweep = 15 min, 10 to 200 Hz sweep: 3G
Warranty	One year – parts and labour

Ordering Information

TW1010 – GPS L1 antenna, 33-1010-xx-yyyy-zz
TW1012 – GPS L1 antenna 33-1012-xx-yyyy-zz
Where xx = connector type yyyy= cable length (in mm) and zz = reserved for Tallysman's use

Please refer to the Ordering Guide (<http://www.tallysman.com/wp-content/uploads/Current-Ordering-Guide.pdf>) for the current and complete list of available connectors.

Tallysman Wireless Inc

36 Steacie Drive
Ottawa ON K2K 2A9 Canada
Tel +1 613 591 3131

Fax 613 591 3121

sales@tallysman.com

The information provided herein is intended as a guide only and is subject to change without notice. This document is not to be regarded as a guarantee of performance. Tallysman Wireless Inc. hereby disclaims any or all warranties and liabilities of any kind. © 2011 Tallysman Wireless Inc. All rights reserved.

Rev 3.7