

REVISIONS				
P.	LTN	DESCRIPTION	DATE	OWN APVD
K		REVISED PER ECR-14-016951	11FEB2015	J.T. W.H

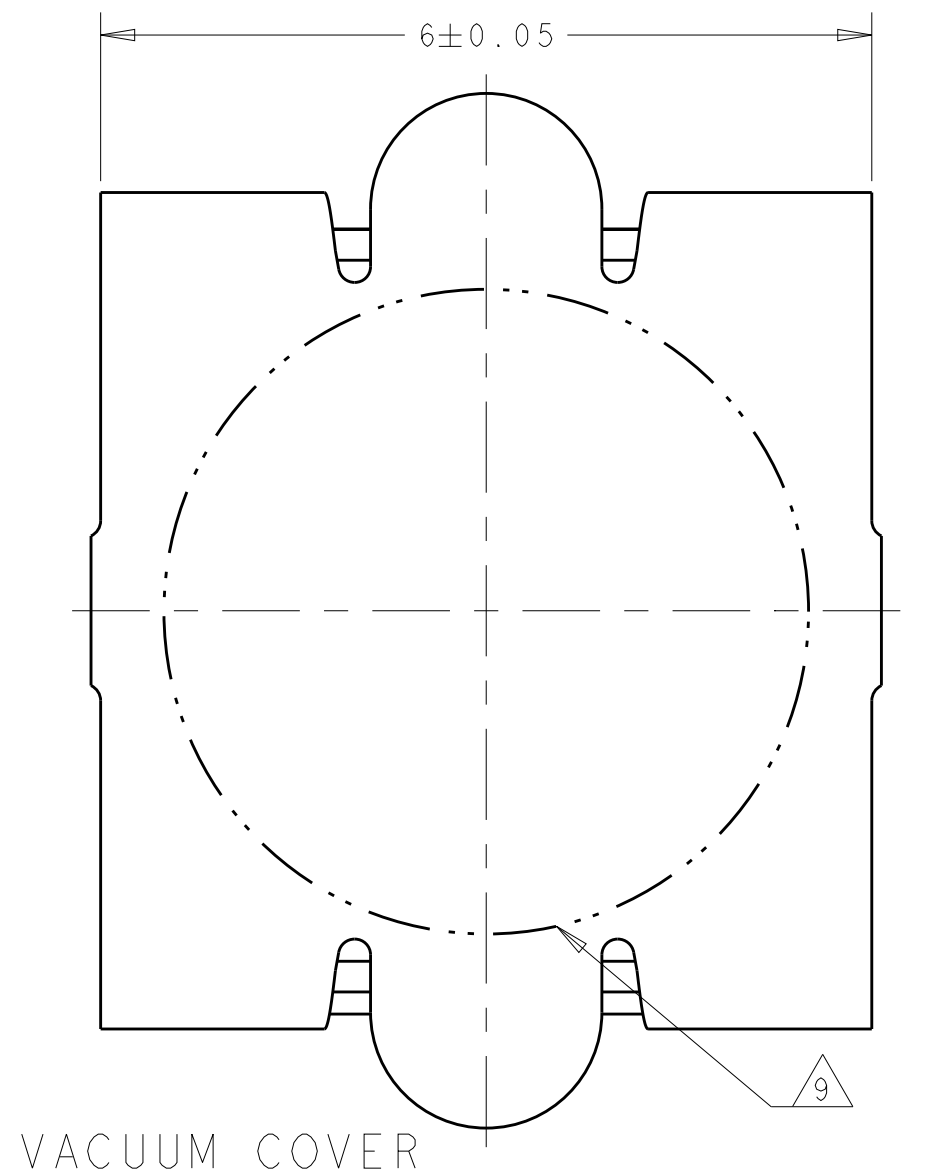

VACUUM COVER

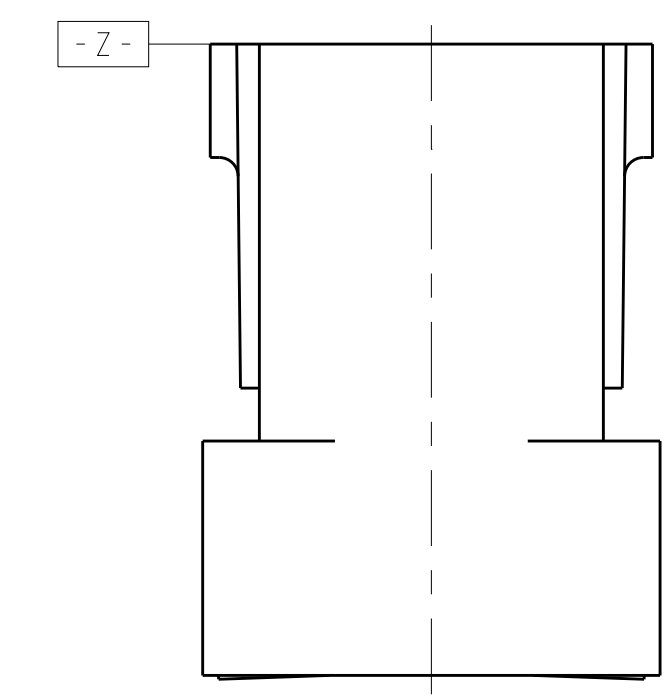
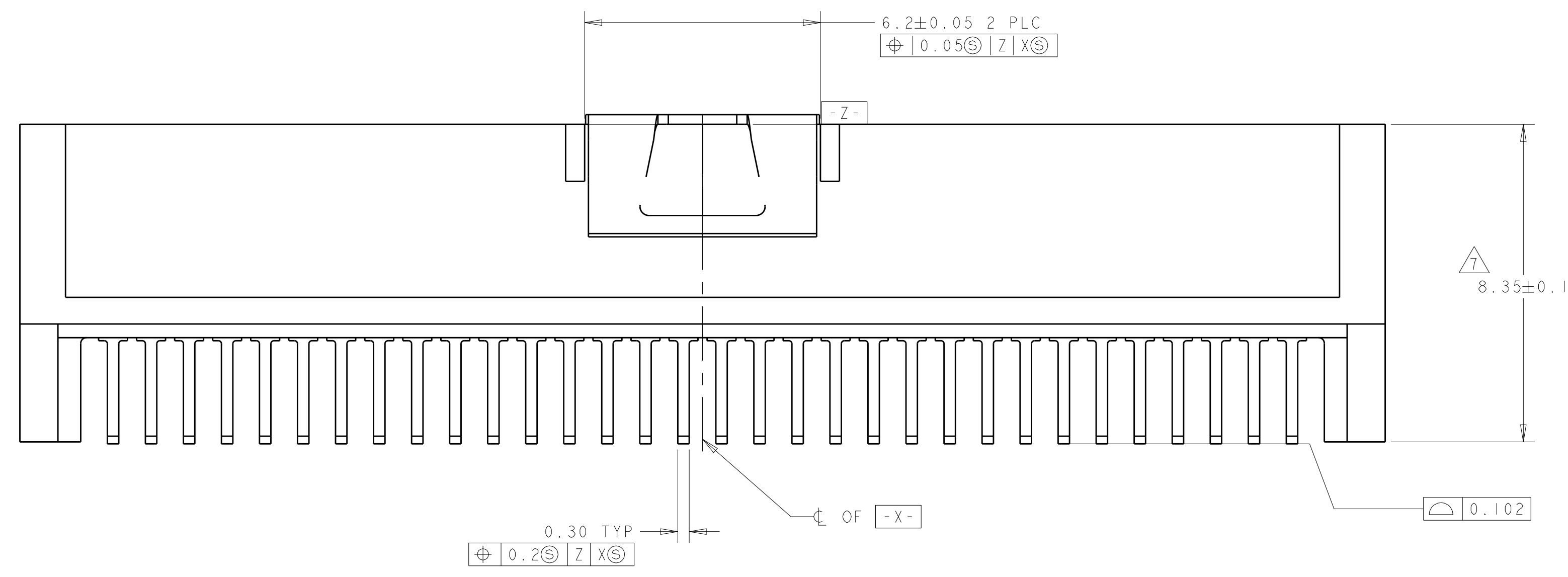
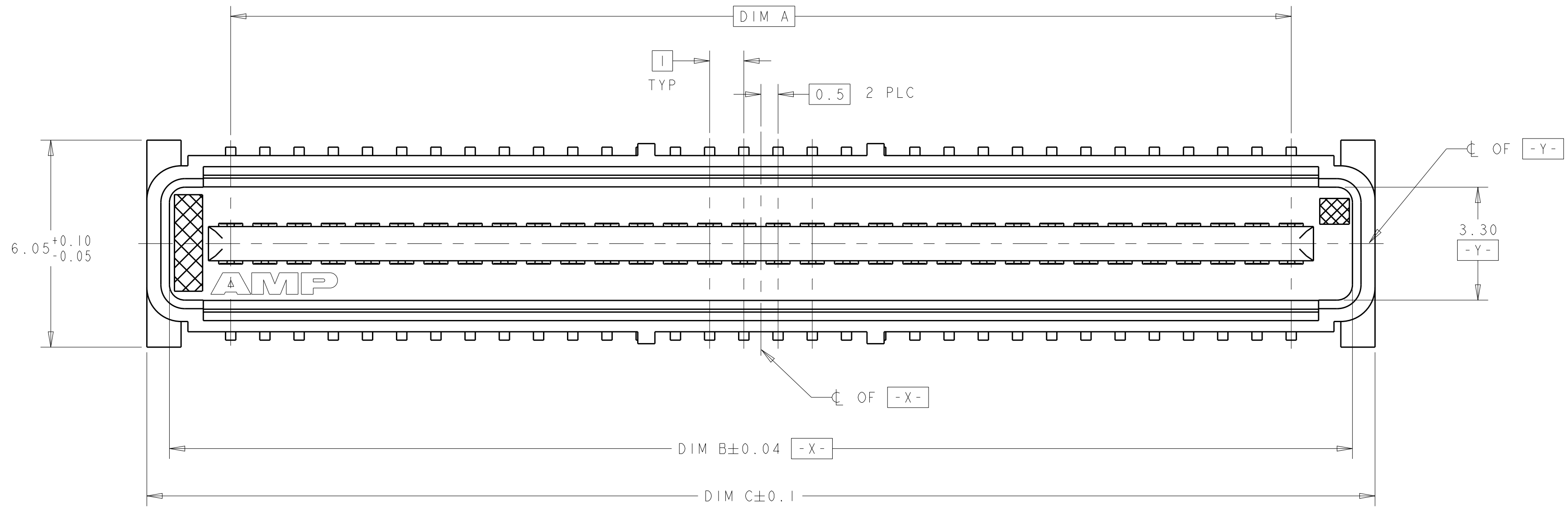
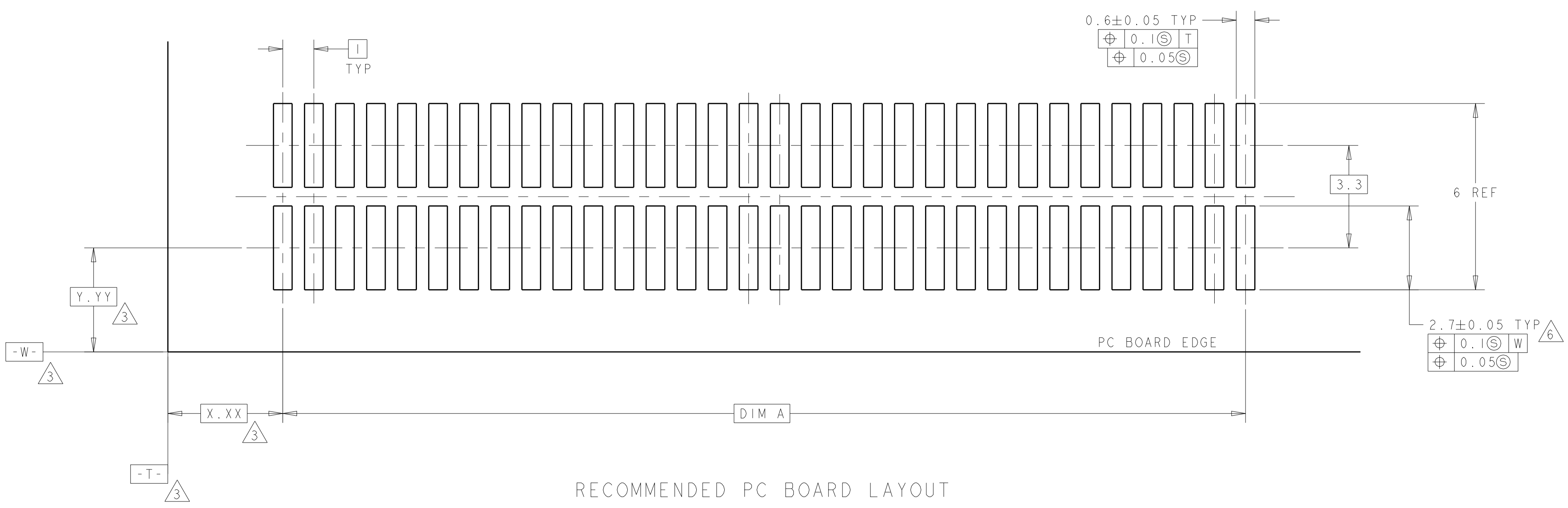

- 1 HOUSING MATERIAL: LIQUID CRYSTAL POLYMER COLOR: BLACK. CONTACT MATERIAL: PHOSPHOR BRONZE.
- 2 CONTACT FINISH: NICKEL UNDERPLATE ALL OVER. MATING SURFACES PLATED TO MEET PLI PERFORMANCE REQUIREMENTS OF INDUSTRY SPECIFICATION EIA-700AAAB, SOLDER TAILS PLATED TIN-LEAD.
- 3 DATUM LOCATIONS AND BASIC DIMENSIONS TO BE ESTABLISHED BY THE CUSTOMER. CONSULT AMP ENGINEERING WHEN PLACING MULTIPLE CONNECTORS ON A PC BOARD.
- 4 PACKAGED IN TAPE ON REEL PER EIA-481.
- 5 VACUUM COVER DESIGNED FOR 4mm DIA. NOZZLE. VACUUM COVER TO BE REMOVED AFTER SOLDERING. VACUUM COVER REMOVED FROM SOME VIEWS FOR DIMENSIONAL CLARITY.
- 6 SHORTER SOLDER LANDS MAY BE USED PER EIA 700AAAB, HOWEVER 2.7 LENGTH ASSURES OPTIMUM SOLDER FILLET REGARDLESS OF MANUFACTURER OF CONNECTOR.
- 7 REFERRED TO AS DIM N IN EIA 700AAAB SPECIFICATION.
- 8 CORRUGATED REEL, HOLDS 400 CONNECTORS PER REEL 330.2[13.00] DIA REEL; 88.9[3.50] REEL CORE. PLASTIC REEL, HOLDS 250 CONNECTORS PER REEL 330.2[13.00] DIA REEL; 177.8[7.00] REEL CORE.
- 9 5.5 MIN DIAMETER TARGET AREA FOR VACUUM PICK-UP.
- 10 CONTACT FINISH: 0.002 MINIMUM BRIGHT TIN-LEAD (93-7) ON SOLDER AREA, 0.00127 MINIMUM GOLD ON MATING AREA, BOTH OVER 0.00127 MINIMUM NICKEL ON ENTIRE CONTACT.
- 11 OBSOLETE PART NUMBER.

FINISH	REEL QTY	DIM C	DIM B	DIM A	MATING CONNECTOR	STACK HEIGHTS	POS	AMP PART NUMBER
10	400	45.9	44.58	41	120531-2	15	84	1-120534-2
10	400	45.9	44.58	41	120530-2	13	84	1-120534-2
10	400	45.9	44.58	41	120529-2	12	84	1-120534-2
10	400	45.9	44.58	41	120528-2	10	84	1-120534-2
10	400	35.9	34.58	31	120531-1	15	64	1-120534-1
10	400	35.9	34.58	31	120530-1	13	64	1-120534-1
10	400	35.9	34.58	31	120529-1	12	64	1-120534-1
10	400	35.9	34.58	31	120528-1	10	64	1-120534-1
11	250	35.9	34.58	31	120531-1	15	64	120534-3
11	250	35.9	34.58	31	120529-1	12	64	120534-3
11	250	35.9	34.58	31	120528-1	10	64	120534-3
2	400	45.9	44.58	41	120531-2	15	84	120534-2
2	400	45.9	44.58	41	120530-2	13	84	120534-2
2	400	45.9	44.58	41	120529-2	12	84	120534-2
2	400	45.9	44.58	41	120528-2	10	84	120534-2
2	400	35.9	34.58	31	120531-1	15	64	120534-1
2	400	35.9	34.58	31	120530-1	13	64	120534-1
2	400	35.9	34.58	31	120529-1	12	64	120534-1
2	400	35.9	34.58	31	120528-1	10	64	120534-1

THIS DRAWING IS A CONTROLLED DOCUMENT. OWN: REED 2/19/97
 DIMENSIONS: mm TOLERANCES UNLESS OTHERWISE SPECIFIED:
 0 PLC ±
 1 PLC ±0.03
 2 PLC ±0.03
 3 PLC ±0.03
 4 PLC ±
 ANGLES 40° 30'
 MATERIAL: SEE TABLE
 FINISH: 1

DATE: 2/19/97
 NAME: PLUG ASSY, W/COVER
 1.0mm FH(IEEE1386) CONNECTOR
 SIZE: A1
 CAGE CODE: 120534
 DRAWING NO: 120534
 SCALE: 17:1
 SHEET: 1 OF 1
 REV: K

STE TE Connectivity