

TOP VIEW

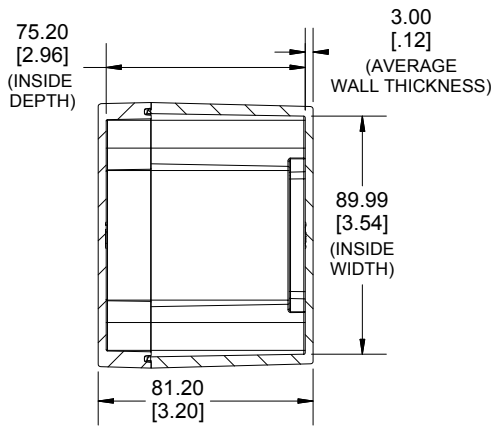

**SECTION A-A
END VIEW**

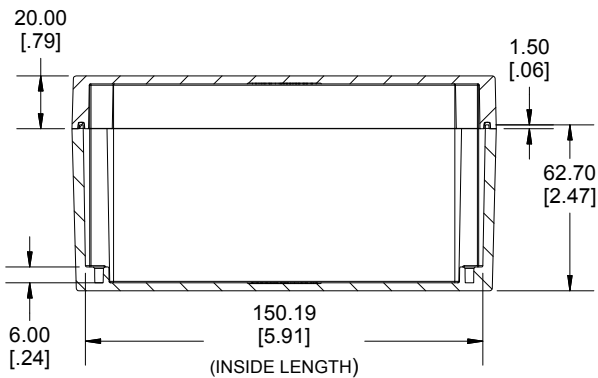

**SECTION B-B
SIDE VIEW**

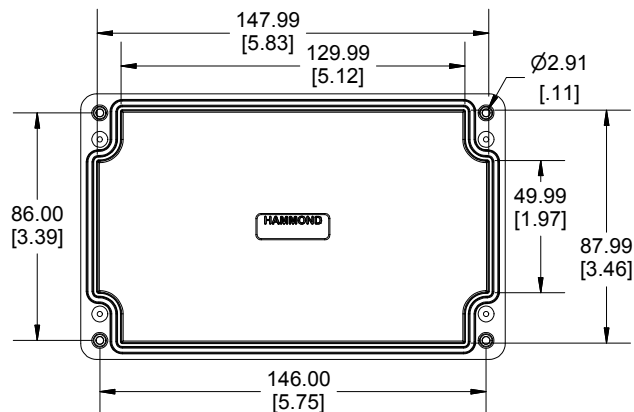

INSIDE LID

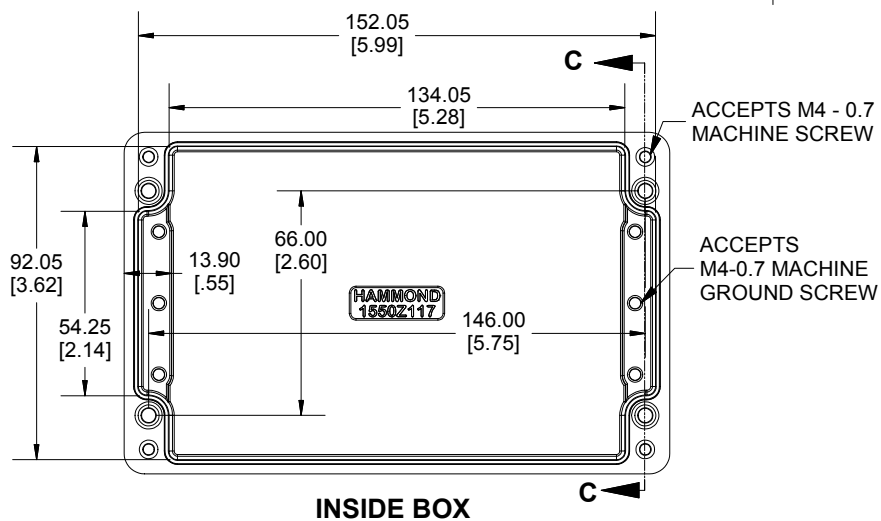

INSIDE BOX

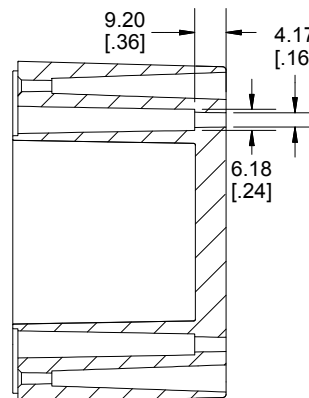

**SECTION C-C
MOUNTING HOLE**

Dimensions:
mm
[inches]

UL US LISTED
FILE #E71073
NEMA 4, 4X

Enclosures can be Factory Modified (Milling, Drilling, Printing etc.)
Contact Factory mjm@hammondmfg.com for quotes
Solid models of this enclosure available in STEP or IGES.
(Part number and text placement/orientation on our products are subject to change,
we do not recommend using them as a locating reference for modification purposes)

NOTE

Purchased assembly includes box, lid, silicone gasket, and 4 cover screws.
Box and lid are made from Diecast Aluminum Alloy.

Screws should not be torqued past 5-7.5 lbf.in (50 -75 cN.m)

PART NUMBERS

1550Z117 Enclosure

Basic Enclosure

1550Z117

Black Enclosure

1550Z117BK

ACCESSORIES

Pre-Formed Silicone Gasket

1550Z117GASKET



**HAMMOND
MANUFACTURING**

1550Z117

www.hammondmfg.com